

PROJECT DIRECTORY:

OWNER: KEVIN & SUZETTE PIPER
8429 SE 33RD PLACE
MERCER ISLAND, WA 98040

ARCHITECT: FORM + FUNCTION ARCHITECTURE
1800 WESTLAKE AVE N., SUITE 205
SEATTLE, WA 98109
(206) 372-9796
CONTACT: JUDY TUCKER, AIA

STRUCTURAL ENGINEERING:
CT ENGINEERING INC.
180 NICKERSON ST SUITE 302
SEATTLE, WA 98109
(206) 285-4512
CONTACT: BEN McCANN

GEOTECHNICAL ENGINEERING:
ZIPPER GEO ASSOC.
19019 36TH AVE W, STE E
LYNNWOOD, WA 98036
(425) 582-9928
CONTACT: DAVE MATTHEWS

SURVEYOR: APEX ENGINEERING
2601 S 35TH ST, STW 200
TACOMA, WA 98409
(253) 473-4494
CONTACT: KURT PARCHER

TABLE OF CONTENTS:

A 1.0	SITE PLAN & PROJECT NOTES
A 1.1	DETAILED SITE PLAN, TEMPORARY EROSION & SEDIMENT CONTROL PLAN
A 2.0	BASEMENT PLAN
A 2.1	MAIN FLOOR PLAN
A 3.0	WEST EXTERIOR ELEV., WINDOW SCHED., ROOF PLAN
A 3.1	EXTERIOR ELEVATIONS
A 3.2	SECTIONS, DOOR SCHEDULE
A 3.3	SECTION B-B, STAIR SECTION & DETAILS
STRUCTURAL	
S 1.0	STRUCTURAL NOTES
S 1.1	SHEARWALL SCHEDULE & DETAILS
S 1.2	HOLDDOWN SCHEDULE & DETAILS
S 2.0	BASEMENT LEVEL WALLS OVER FOUNDATION
S 2.1	MAIN LEVEL FRAMING PLAN OVER BASEMENT LEVEL SHEARWALLS
S 2.2	ROOF FRAMING PLAN OVER MAIN LEVEL SHEARWALLS
S 6.0	TYPICAL CONCRETE DETAILS
S 8.0	MOMENT FRAME DETAILS
S 8.1	MOMENT FRAME DETAILS
S 8.2	MOMENT FRAME DETAILS
S 8.3	MOMENT FRAME DETAILS
S 9.0	TYPICAL WOOD FRAMING DETAILS
S 9.1	TYPICAL WOOD FRAMING DETAILS
S 9.2	TYPICAL WOOD FRAMING DETAILS
S 10.0	TYPICAL COMPONENTS
SURVEY	
TOPOGRAPHIC SURVEY	

PROJECT NOTES:

PROJECT DESCRIPTION: REMODEL MAIN FLOOR KITCHEN, MOVE STAIRS TO NEW REAR YARD ADDITION, NEW REAR YARD COVERED DECK, NEW SIDE YARD MUDROOM ADDITION TO CONNECT HOUSE TO GARAGE, NEW GUEST BATH, NEW MAIN FLOOR MASTER SUITE, NEW ROOF.

KING COUNTY ASSESSOR
PARCEL NUMBER: 6666800250
PROJECT ADDRESS: 8429 SE 33RD PL MERCER ISLAND, WA 98040
LEGAL DESCRIPTION: PARKRIDGE ADD, LOT 25
ZONING: SF 9.6
CONSTRUCTION TYPE: TYPE V B
ENVIRONMENTAL CRITICAL AREAS: LANDSLIDE HAZARD, EROSION CONTROL

LOT AREA: 19,302 SF (0.44 ACRES)
GROSS FLOOR AREA: 40% OF 19,302= 8,685.9 SF
NEW & EXISTING HOUSE+ COVERED DECK + GARAGE = 4082.2 SF (> 8685.9- OK)

SETBACKS: FRONT YARD: 20' MIN
REAR YARD: 25' MIN
SIDE YARD: 5' MIN, 15' COMBINED

LOT SLOPE: BASED ON LOT SLOPE. LOW ELEVATION = 192.0' HIGHEST ELEVATION = 270.0'
(270.0-192.0)/163.7' LOT SLOPE LINE = 47.6% SLOPE
30% - 50% LOT SLOPE ALLOWS FOR 30% LOT COVERAGE
30% OF 19,302 SF=5,790.6 SF

LOT COVERAGE:	EXIST ROOF = 2659.6 SF	NEW ROOF = 196.6 SF
	EXIST. DRIVEWAY = 2310.3 SF	EXIST. SHED = 205.9 SF
	NEW COVERED PATIO/ DECK = 413.4 SF	TOTAL LOT COVERAGE= 5785.8 SF (30%)
	ALLOWABLE LOT COVERAGE: 5790.6 SF (30%)	
IMPERVIOUS SURFACE:	EXIST ROOF = 2659.6 SF	NEW ROOF = 196.6 SF
	NEW COVERED PATIO/ DECK = 413.4 SF	EXIST. DRIVEWAY = 2310.3 SF
	EXIST. SHED = 205.9 SF	NEW CONC. PATIO = 369.9 SF
	EXIST. CONC. PATIO (TO BE REMOVED) = -533.3 SF	TOTAL IMPERVIOUS SURFACE= 5622.4 SF (29%)
	TOTAL IMPERVIOUS SURFACE= 5622.4 SF (29%)	CHANGE IN IMPERVIOUS SURFACE= 446.6 SF
	ALLOWABLE IMPERVIOUS SURFACE: 6755.7 SF (35%)	
HARDSCAPE SURFACE:	EXIST UNCOVERED PATIOS = 533.3 SF	EXIST WALKWAYS = 100.0 SF
	EXIST. ROCKERIES/RETAINING WALLS = 75.0 SF	NEW UNCOVERED PATIOS = 490.9 SF
	EXIST. CONC. PATIO (TO BE REMOVED) = -533.3 SF	AREA BORROWED FROM LOT COVERAGE= 4.8 SF
	TOTAL HARDSCAPE AREA (665.9 + 4.8)= 670.7 SF (3.5%)	ALLOWABLE HARDSCAPE: 1737.2 SF (9%)

SEE SHEET A2.1 FOR TOTAL NEW HARD SURFACE CALCULATIONS

GROSS FLOOR AREA: 1456.1 (BSMT SF) X 61.7% (BELOW GRADE %) = 899.24 SF

WALL SEGMENT	LENGTH X	COVERAGE =	RESULT
A	27.1	50.6	15.2
B	53.7	7	3.8
C	27.1	100	27.1
D	53.7	100	53.7
TOTALS	161.6		99.8

BUILDING HEIGHT: MAX 30' ABE (AVERAGE BUILDING ELEVATION):
(MID POINT ELEVATION X LENGTH OF WALL) / TOTAL LENGTH OF WALL SEGMENTS
(60,044.25) / 229 = 262.2' ABE

BUILDING HEIGHT: AVERAGE GRADE= (Aa)+(Bb)+(Cc)+(Dd)/(a+b+c+d) =
A=267.6 a=64.2
B=262.7 b=66.1
C=269.9 c=64.2
D=269.0 d=66.1

(267.6x64.2)+(262.7x66.1)+(269.9x64.2)+(269.0x66.1)/64.2+66.1+64.2+66.1= 267.3'
AVERAGE EXISTING GRADE= 267.3', ALLOWABLE HT = 297.3'

VICINITY MAP:

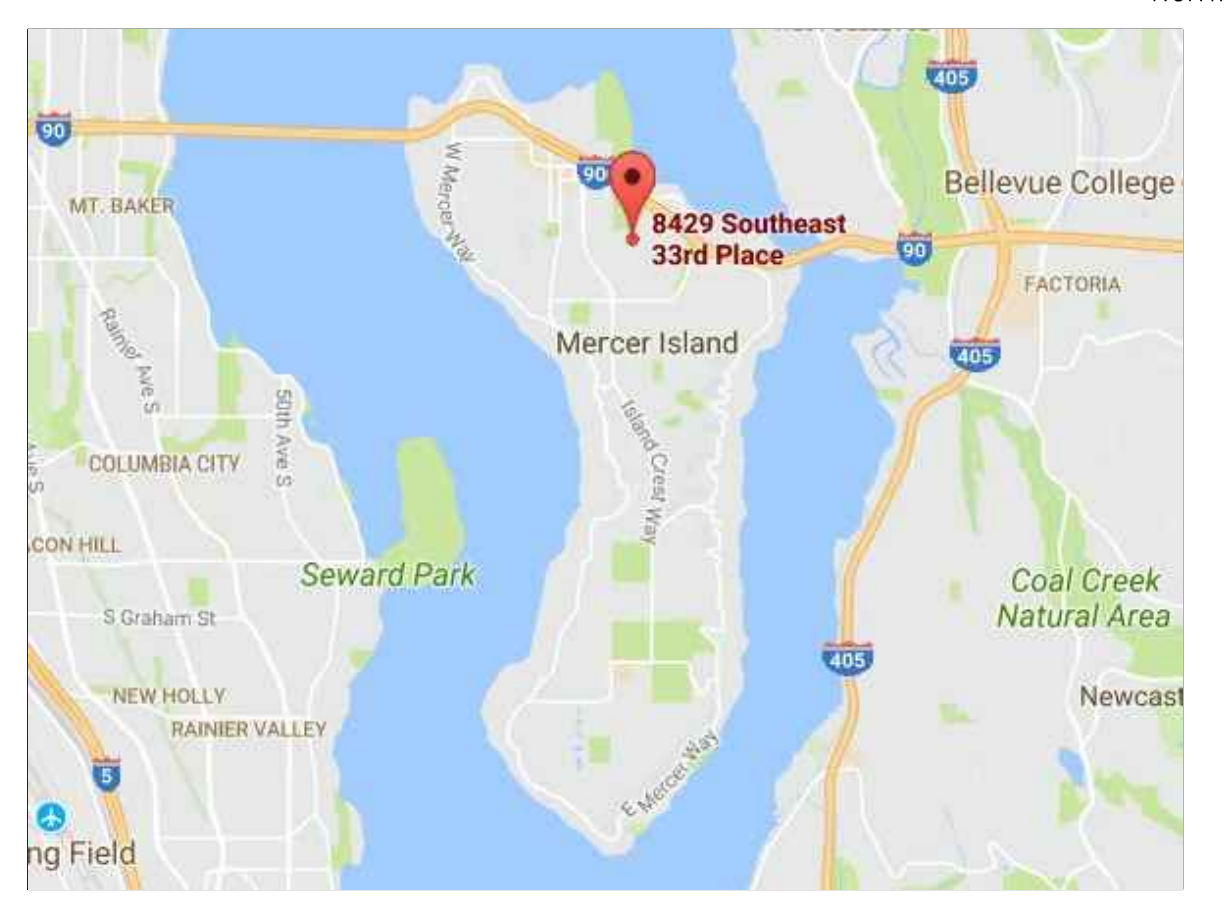

SITE KEY PLAN
SEE SHT A1.1 FOR SITE DIMENSIONS/ PROJECT NOTES

SCALE= 1/16" = 1'-0"

CODE NOTES:

- OPENINGS SHALL BE CAULKED, OR WEATHER STRIPPED.
- SEAL TEARS AND JOINTS IN INSULATION WITH TAPE.
- MOISTURE CONTROL TO BE PROVIDED PER WA STATE ENERGY CODE.
- HOT WATER HEATERS SHALL COMPLY WITH THE NATIONAL APPLIANCE ENERGY CONSERVATION ACT. (EXISTING WH TO REMAIN)
- PROVIDE SEISMIC STRAP FOR WATER HEATER. (VERIFY EXISTING OR PROVIDE NEW)
- SERVICE WATER PIPES IN UNHEATED SPACES SHALL BE INSULATED PER WA STATE ENERGY CODE.
- ALL NAILING PER IRC
- PROVIDE SMOKE DETECTORS PER IRC - IN EACH SLEEPING ROOM, OUTSIDE EACH SEPARATE SLEEPING AREA AND ON EACH STORY OF THE HOUSE. CONTRACTOR TO VERIFY SD'S ARE PROPERLY INSTALLED IN THE EXISTING HOUSE.
- SMOKE DETECTORS SHALL BE POWERED BY THE BUILDING WIRING WITH A BATTERY BACKUP.
- CARBON MONOXIDE ALARMS TO BE INSTALLED PER IRC- OUTSIDE OF EACH SEPARATE SLEEPING AREA IN THE IMMEDIATE VICINITY OF BEDROOMS. CONTRACTOR TO VERIFY.
- PROVIDE FIRE BLOCKING, DRAFTSTOPS AND FIRESTOPS PER THE IRC.
- PROVIDE APPROVED SECURITY AND LOCKING DEVICES AT NEW DOORS AND WINDOWS PER IRC.

GENERAL NOTES:

1. ALL WORK UNDER THIS CONTRACT SHALL COMPLY WITH THE CURRENT EDITIONS OF THE INTERNATIONAL RESIDENTIAL CODE (2018), WASHINGTON STATE ENERGY CODE (2018), WASHINGTON STATE VENTILATION AND INDOOR AIR QUALITY CODE, UNIFORM PLUMBING CODE, NATIONAL ELECTRIC CODE, AND WASHINGTON STATE DEPARTMENT OF LABOR AND INDUSTRIES REGULATIONS.
2. GENERAL CONTRACTOR SHALL VERIFY AND COORDINATE ALL EXISTING AND NEW UTILITIES AND SITE CONDITIONS BEFORE AND DURING CONSTRUCTION. INFORM ARCHITECT OF VARIATIONS BETWEEN CONTRACT DOCUMENTS AND EXISTING CONDITIONS.
3. DO NOT SCALE DRAWINGS; VERIFY ALL DIMENSIONS ON THE JOB.
4. DIMENSIONS ARE TO FACE OF FOUNDATION WALLS AND FACE OF ROUGH FRAMING, UNLESS NOTED OTHERWISE. FOR DIMENSIONS TO EXIST. STRUCTURE - ASSUME FACE OF (E) FINISHED SURFACE.
5. FLOOR-TO-FLOOR DIMENSIONS FROM TOP OF SUBFLOOR TO TOP PLATES, UNLESS NOTED OTHERWISE.
6. PROVIDE SOLID BLOCKING BEHIND ALL WALL HUNG FIXTURES AND ACCESSORIES.

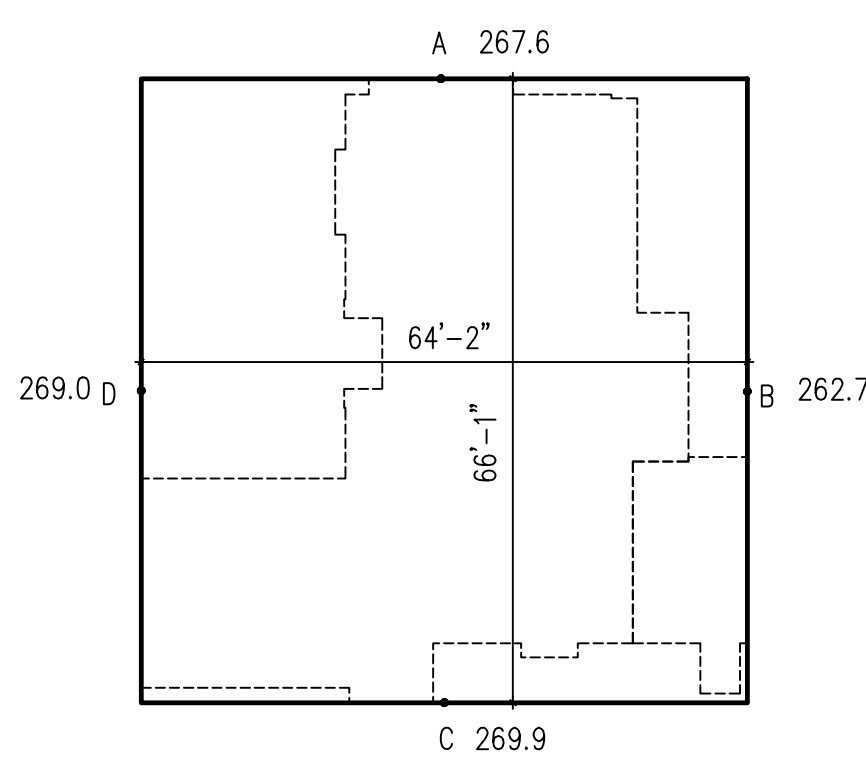

ENCLOSING RECTANGLE DIAGRAM

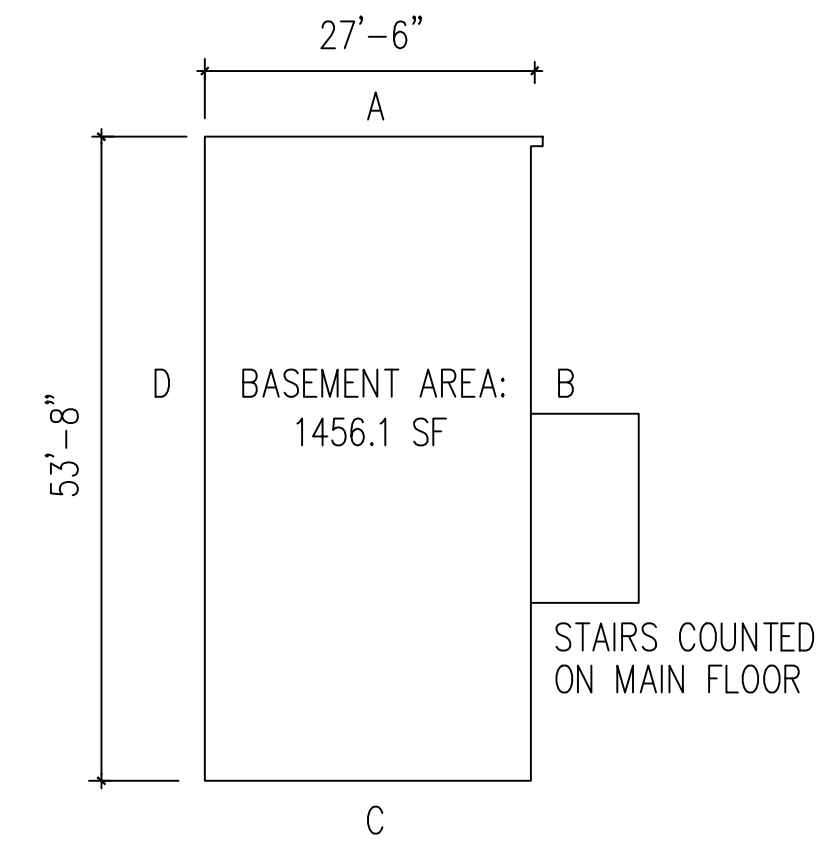

GROSS FLOOR AREA

STAIRS COUNTED ON MAIN FLOOR

NO.	REVISION DATE

FORM + FUNCTION ARCHITECTURE
1800 WESTLAKE AVE. N. #205 SEATTLE, WA 98109
206.372.9796

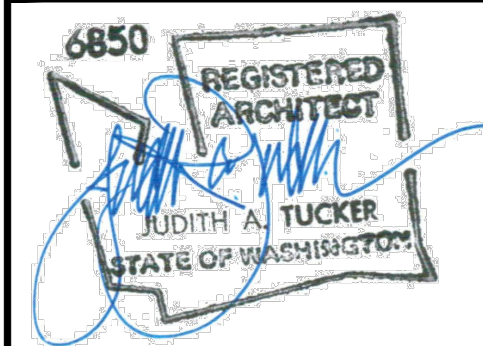

PIPER REMODEL
8429 SE 33RD PL
MERCER ISLAND, WA
98040

DATE: 3/29/22

DRAWN BY: JT SD

CHECKED BY: JT

SHEET TITLE
SITE PLAN
PROJ INFO

SHEET NO.

A1.0

NO.	REVISION DATE

FORM + FUNCTION
ARCHITECTURE
1800 WESTLAKE AVE. N. #205 SEATTLE, WA 98109
206.372.9796

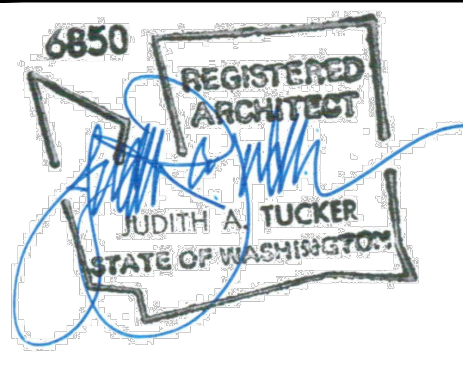

PIPER REMODEL
8429 SE 33RD PL
MERCER ISLAND, WA
98040
PROJECT NO. 1212

DATE	3/4/22
DRAWN BY	JT SD
CHECKED BY	JT
SHEET TITLE	SITE PLAN
TEMP. EROSION & SEDIMENT CONTROL	

SHEET NO.
A1.1

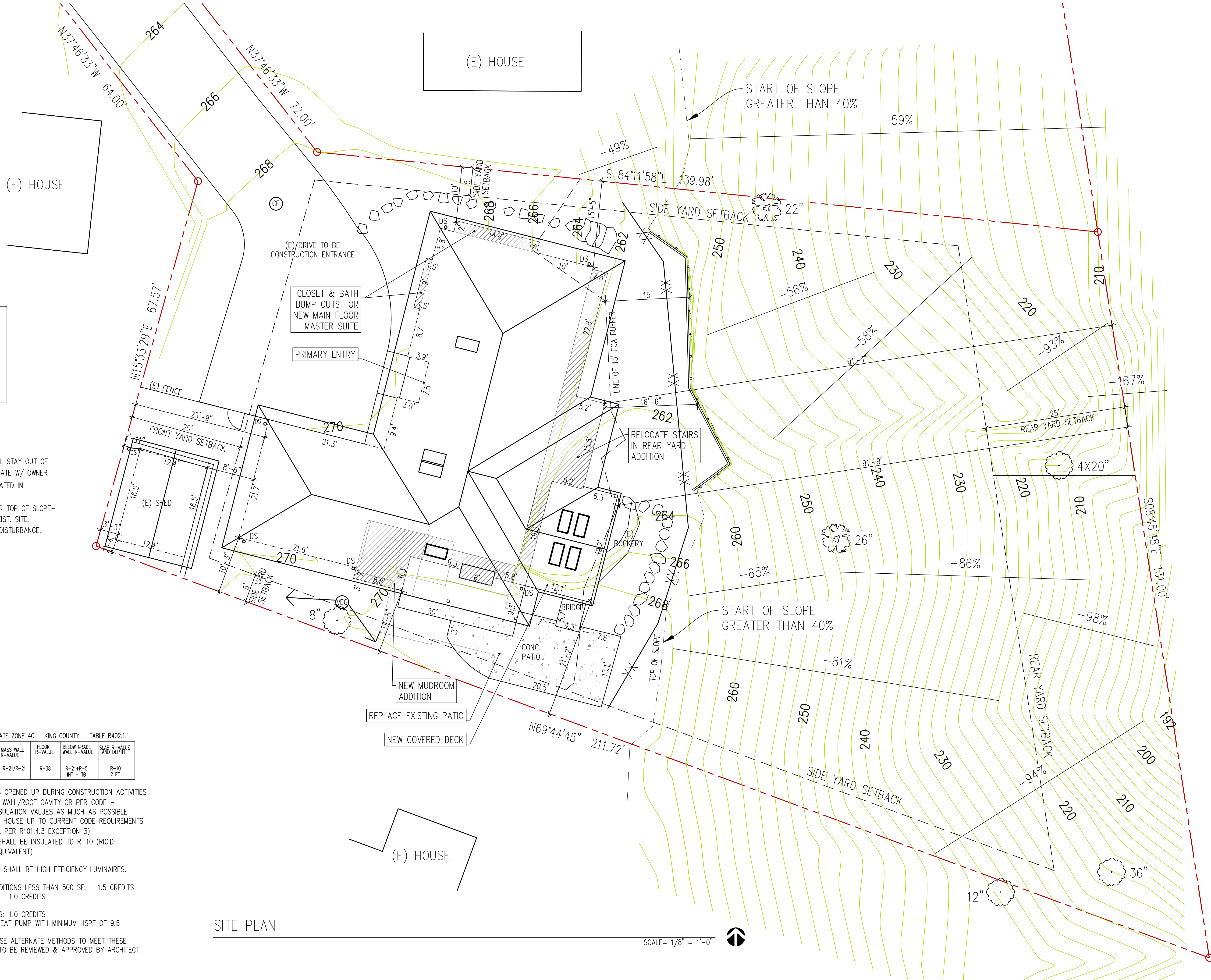

LEGEND

	CONSTRUCTION ACCESS
	FILTER FENCE
	TREE & VEGETATION PROTECTION

- NOTES:
- PROTECT EXIST. TREES DURING CONSTRUCTION. STAY OUT OF DRIP LINES/ OFF ROOTS IF POSSIBLE. COORDINATE W/ OWNER ON ALL PLANTINGS TO BE SALVAGED/ RELOCATED IN CONSTRUCTION AREAS.
 - NO CONSTRUCTION ACTIVITIES TO OCCUR NEAR TOP OF SLOPE- CONTRACTOR TO UTILIZE BMP TO PROTECT EXIST. SITE, VEGETATION, & ROCKERIES TO MINIMIZE SITE DISTURBANCE.

ENERGY NOTES: WSEC 2018

INSULATION & FENESTRATION REQMS BY COMPONENT - CLIMATE ZONE 4C - KING COUNTY - TABLE R402.1.1

FENESTRATION U-FACTOR	SKYLIGHT U-FACTOR	CEILING R-VALUE	WOOD FRAMED WALL R-VALUE	MASS WALL R-VALUE	FLOOR R-VALUE	BELOW GRADE WALL R-VALUE	SLAB R-VALUE AND DEPTH
.24	.50	R-38 VAULTED R-49 FLAT	R-21+ R-4	R-21/R-21	R-38	R-21+R-5 INT + TB	R-10 2 FT

- ALL EXISTING WALL, FLR, CLG AND ROOF AREAS OPENED UP DURING CONSTRUCTION ACTIVITIES WILL BE INSULATED PER THE CAPACITY OF THE WALL/ROOF CAVITY OR PER CODE - WHICHEVER IS LESS- INTENT IS TO IMPROVE INSULATION VALUES AS MUCH AS POSSIBLE WITHIN THE EXISTING FRAMEWORK BRINGING THE HOUSE UP TO CURRENT CODE REQUIREMENTS (2X6=R-21 BATT INSUL, 2X4=R-15 BATT INSUL PER R101.4.3 EXCEPTION 3)
ALL NEW HEADERS IN EXTERIOR WALLS SHALL BE INSULATED TO R-10 (RIGID INSULATION BETWEEN 2-2X8'S - 4X8 EQUIVALENT)
 - MINIMUM 75% OF ALL NEW INTERIOR LUMINAIES SHALL BE HIGH EFFICIENCY LUMINAIES.
 - ADDITIONAL ENERGY CREDITS REQUIRED FOR ADDITIONS LESS THAN 500 SF: 1.5 CREDITS HEATING OPTIONS: HEAT PUMP 1.0 CREDITS
 - 3 - HIGH EFFICIENCY HVAC EQUIPMENT OPTIONS: 1.0 CREDITS
3.2 AIR-SOURCED CENTRALLY DUCTED HEAT PUMP WITH MINIMUM HSPF OF 9.5
- CONTRACTOR ALSO HAS THE OPTION TO PROPOSE ALTERNATE METHODS TO MEET THESE ADDITIONAL ENERGY CREDITS - THESE OPTIONS ARE TO BE REVIEWED & APPROVED BY ARCHITECT.

SITE PLAN

SCALE= 1/8" = 1'-0"



LEGEND	
	EXISTING TO REMAIN
	EXISTING TO BE DEMOLISHED
	NEW WALLS

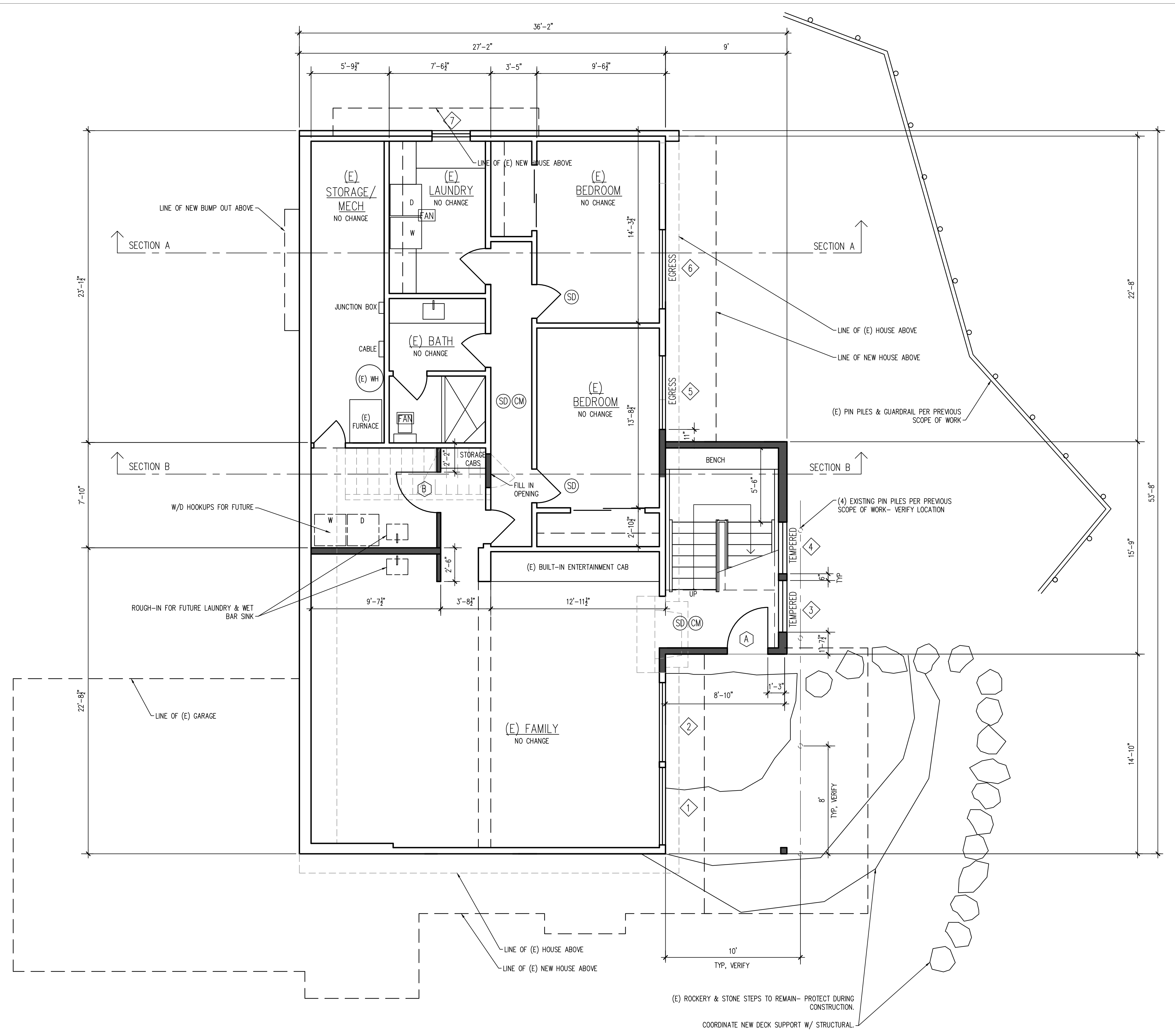

- STAIR NOTES:**
- WIDTH MIN. 36" CLEAR
 - TREAD DEPTH 10" CLEAR (ALLOW FOR 1" OVERHANG - 11" TOTAL)
 - RISER HEIGHT 7 1/2" +/- VERIFY W/ EXISTING GRADE/ FLOOR HEIGHTS (MAX. HT. 7.75")
 - HANDRAIL MIN. 34", MAX 38" ABOVE TREAD NOSINGS
 - HANDRAIL GRASP MIN. 1-1/4", MAX. 2"
 - HANDRAIL PROJECTION MAX. 4-1/2" FROM EACH SIDE OF STAIRWAY INTO REQUIRED WIDTH. MIN. 1-1/2" BETWEEN THE WALL
 - GUARDRAIL MAX OPENING 4" PER SRC R312.1.3
MIN. UNIFORMLY DISTRIBUTED LIVE LOADS (LBS PER SF)
200LB CONCENTRATED LOAD ON THE TOP RAIL & 50 PSF ON GUARDRAIL INFILL COMPONENTS PER SRC R301.5-
SEE STRUCTURAL FOR DETAILS

- NOTES:**
- CONTRACTOR WILL APPLY FOR PLUMBING, MECHANICAL, ELECTRICAL PERMITS SEPARATELY. CONTRACTOR TO REVIEW EXISTING CONDITIONS PRIOR TO STARTING CONSTRUCTION.
 - ALL WALLS THAT HAVE FINISHES REMOVED WILL BE SUBJECT TO CURRENT CODE RQMTS - INCLUDES PLUMBING/MECHANICAL/ELECTRICAL/INSULATION.
 - WHOLE HOUSE FAN SHALL BE LOCATED/ASSOCIATED WITH THE MAIN FLOOR GUEST BATH FAN, THIS FAN TO BE EQUIPPED WITH CONTROLS CAPABLE OF MANUAL AND AUTOMATIC OPERATION, SUCH AS A CLOCK TIMER AND SHALL BE DESIGNED TO RUN CONTINUOUSLY PER SRC M1507.3.3.
 - CONTRACTOR TO VERIFY EXISTING BASEMENT BATH & LAUNDRY TO HAVE EXHAUST FANS AS REQUIRED BY CODE. (TERMINATING HORIZONTALLY TO THE EXTERIOR OF THE HOUSE.)
 - DOOR JAMBS SHALL BE 3 1/2" TYPICAL, UNLESS NOTED OTHERWISE.
 - SEE SHTS A3.0 & A3.2 FOR WINDOW & DOOR SCHEDULES AND ELEVATIONS (A3.0 & A3.1) FOR ADDITIONAL INFORMATION.

BASEMENT PLAN
VERIFY ALL DIMENSIONS TO EXISTING ELEMENTS

1/4"=1'-0"

NO.	REVISION DATE

FORM + FUNCTION ARCHITECTURE
1800 WESTLAKE AVE. N. #205 SEATTLE, WA 98109
206.372.9796

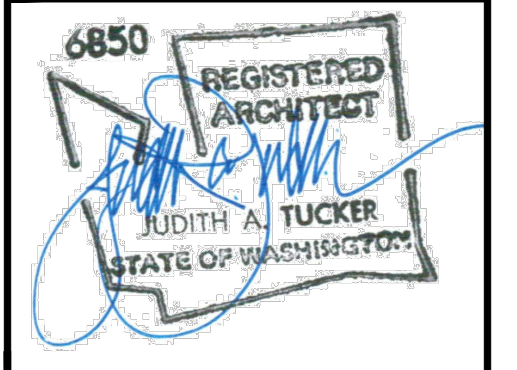

PIPER REMODEL
8429 SE 33RD PL
MERCER ISLAND, WA
98040
PROJECT NO. 1212

DATE	3/4/22
DRAWN BY	JT SM
CHECKED BY	JT
SHEET TITLE	BASEMENT PLAN

SHEET NO.
A2.0

LEGEND	
	EXISTING TO REMAIN
	EXISTING TO BE DEMOLISHED
	NEW WALLS

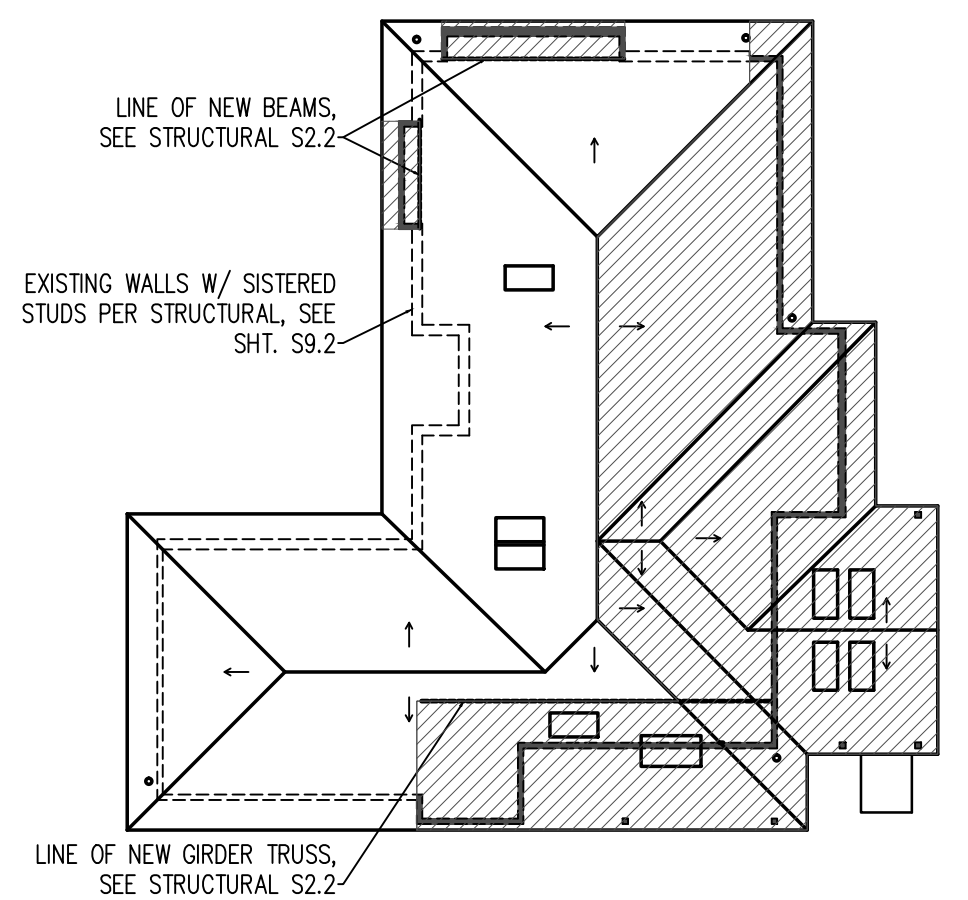
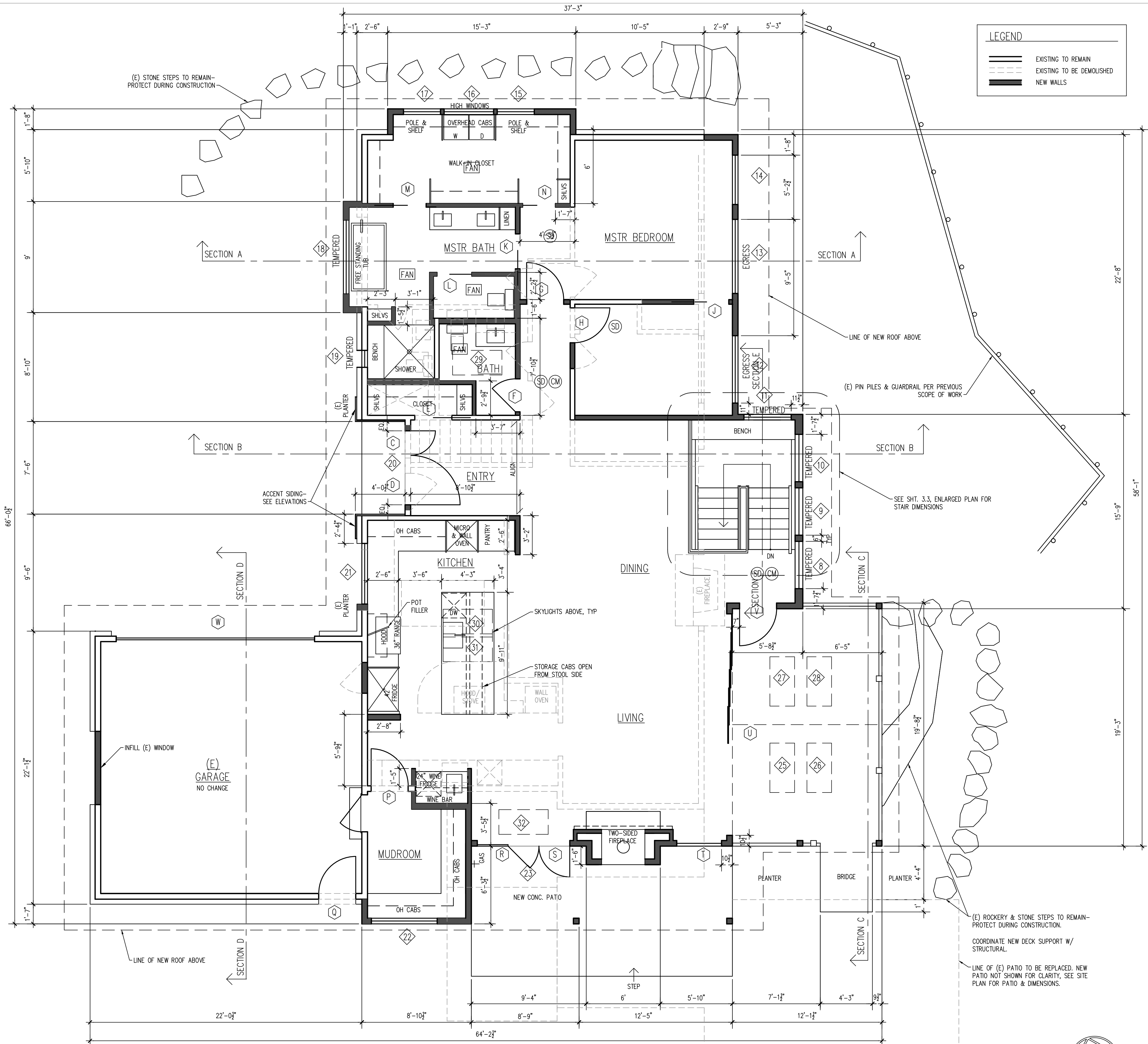

DIAGRAM OF NEW/REPLACED HARD SURFACE FOR STRUCTURES BASED ON SUPPORTED ROOF AREA BY NEW WALLS

NEW/REPLACED HARD SURFACE:		
NORTH BAY =	47.82 SF	
WEST BAY =	28.38 SF	
SOUTH/EAST ADDITION =	1493.38 SF	
NEW CONCRETE PATIO =	369.90 SF	
TOTAL =	1939.48 SF	

TOTAL NEW/REPLACED HARD SURFACE IS UNDER THE 2000 SF THRESHOLD, THEREFORE, FULL DRAINAGE PLAN & REPORT BY A CIVIL ENGINEER IS NOT REQUIRED.

STAIR NOTES:

- WIDTH MIN. 36" CLEAR
- TREAD DEPTH 10" CLEAR (ALLOW FOR 1" OVERHANG - 11" TOTAL)
- RISER HEIGHT 7 1/2" +/- VERIFY W/ EXISTING GRADE/ FLOOR HEIGHTS (MAX. HT. 7.75")
- HANDRAIL MIN. 34", MAX 38" ABOVE TREAD NOSINGS
- HANDRAIL GRASP MIN. 1-1/4", MAX. 2"
- HANDRAIL PROJECTION MAX. 4-1/2" FROM EACH SIDE OF STAIRWAY INTO REQUIRED WIDTH. MIN. 1-1/2" BETWEEN THE WALL
- GUARDRAIL MAX OPENING 4" PER SRC R312.1.3
MIN. UNIFORMLY DISTRIBUTED LIVE LOADS (LBS PER SF)
200LB CONCENTRATED LOAD ON THE TOP RAIL & 50 PSF ON GUARDRAIL INFILL COMPONENTS PER SRC R301.5-
SEE STRUCTURAL FOR DETAILS

NOTES:

1. CONTRACTOR WILL APPLY FOR PLUMBING, MECHANICAL, ELECTRICAL PERMITS SEPARATELY. CONTRACTOR TO REVIEW EXISTING CONDITIONS PRIOR TO STARTING CONSTRUCTION.
2. ALL WALLS THAT HAVE FINISHES REMOVED WILL BE SUBJECT TO CURRENT CODE REQMTS - INCLUDES PLUMBING/MECHANICAL/ELECTRICAL/INSULATION.
3. WHOLE HOUSE FAN SHALL BE LOCATED/ASSOCIATED WITH THE MAIN FLOOR GUEST BATH, THIS FAN TO BE EQUIPPED WITH CONTROLS CAPABLE OF MANUAL AND AUTOMATIC OPERATION, SUCH AS A CLOCK TIMER AND SHALL BE DESIGNED TO RUN CONTINUOUSLY PER SRC M1507.3.3.
- 3.1. IN NEW MASTER BATH & CLOSET- INSTALL PANASONIC WHISPERQUIET FAN SIZED PER SPACE. (75 C.F.M., 1.0 SONES OR BETTER). FAN SHALL TERMINATE VERTICALLY TO THE EXTERIOR OF THE HOUSE.
- 3.2. NEW KITCHEN HOOD ON MAIN FLOOR TO BE SELECTED- MIN 100 C.F.M., 1.5 SONES OR BETTER. FANS SHALL TERMINATE HORIZONTALLY TO THE EXTERIOR OF THE HOUSE.
4. DOOR JAMBS SHALL BE 3/4" TYPICAL, UNLESS NOTED OTHERWISE.
5. SEE SHTS A3.0 & A3.2 FOR WINDOW & DOOR SCHEDULES AND ELEVATIONS (A3.0 & A3.1) FOR ADDITIONAL INFORMATION.
6. PROVIDE BLOCKING FOR FUTURE GRAB BARS IN BOTH MAIN FLOOR BATHROOMS.

MAIN FLOOR PLAN

VERIFY ALL DIMENSIONS TO EXISTING ELEMENTS

1/4"=1'-0"

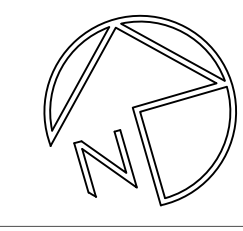

NO.	REVISION DATE

FORM + FUNCTION ARCHITECTURE
 1800 WESTLAKE AVE. N. #205 SEATTLE, WA 98109
 206.372.9796

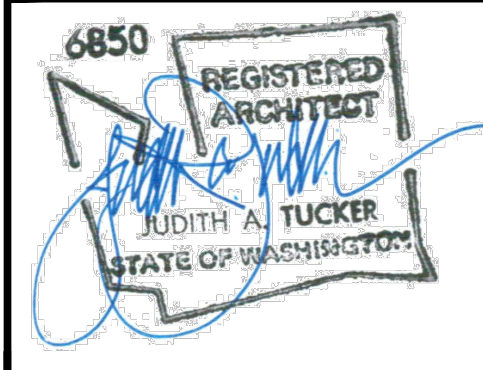

PIPER REMODEL
 8429 SE 33RD PL
 MERCER ISLAND, WA
 98040

PROJECT NO. 1212

DATE 3/29/22

DRAWN BY JT SM

CHECKED BY JT

SHEET TITLE
MAIN FLR PLAN

SHEET NO.

A2.1

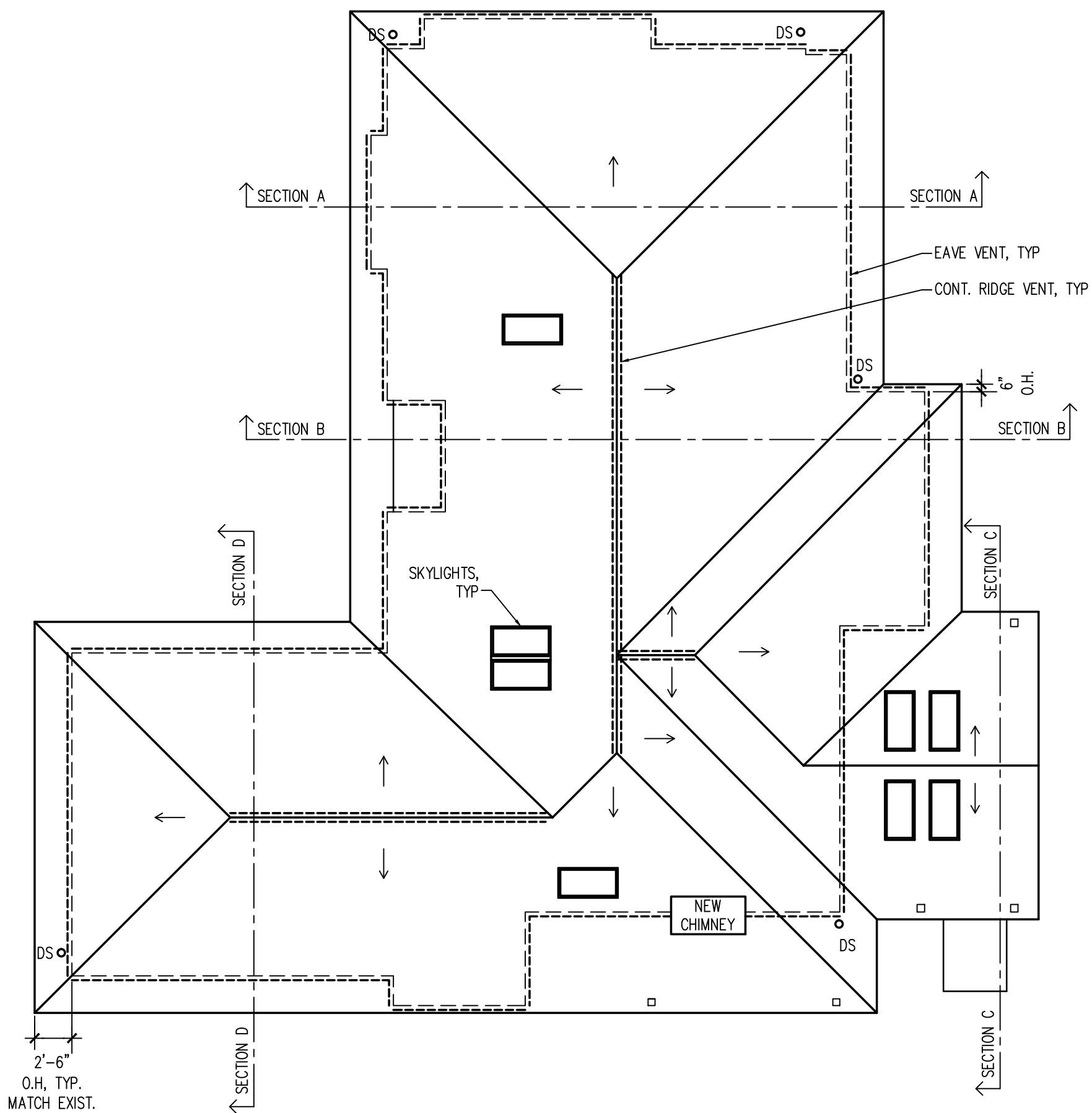

ROOF PLAN
CONNECT ALL NEW GUTTERS/ DOWNSPOUTS TO EXISTING SITE DRAINAGE SYSTEM
1/8"=1'-0"

ROOF VENTILATION NOTES:

CONTRACTOR TO PROVIDE NEW VENTING TO MEET CODE REQUIREMENTS PER IRC R806.2 (SEE NOTES ON ROOF PLAN FOR PROPOSED VENTILATION SOLUTIONS):

1 SQ.FT. OF VENTING PER 300 SQ.FT. OF AREA TO BE VENTED (1/150 REDUCED TO 1/300 PROVIDED THAT AT LEAST 40% AND NOT MORE THAN 50% OF THE RQD VENTING PROVIDED IN THE UPPER PORTION OF THE SPACE - MIN 3' ABOVE EAVE LINE.

1" AIR SPACE REQUIRED ABOVE ROOF INSULATION
EAVE/SOFFIT VENTS - (3) 2" DIAMETER VENTS PER RAFTER BAY 9 SQ IN. +/- PER BAY MIN.

HOUSE/GARAGE: 2396.5 SF/300= 8.0 SF (1152.0 SQ IN) RQD
RIDGE: REQUIRED: 576.0 SQ IN RQD (32.0 LF)
PROPOSED: 1056.5 SQ IN (58.7 LF)

SOFFIT: REQUIRED: 576.0 SQ IN RQD (64 RAFTER BAYS)
PROPOSED: 1053.0 SQ IN (117.0 RAFTER BAYS)

PROPOSED VENTILATION MEETS/EXCEEDS CODE RQMT FOR 1/300 FOR UNIQUE SITUATIONS THAT ARISE DURING CONSTRUCTION COORDINATE VENTILATION (& INSULATION) RQMTS WITH ARCHITECT

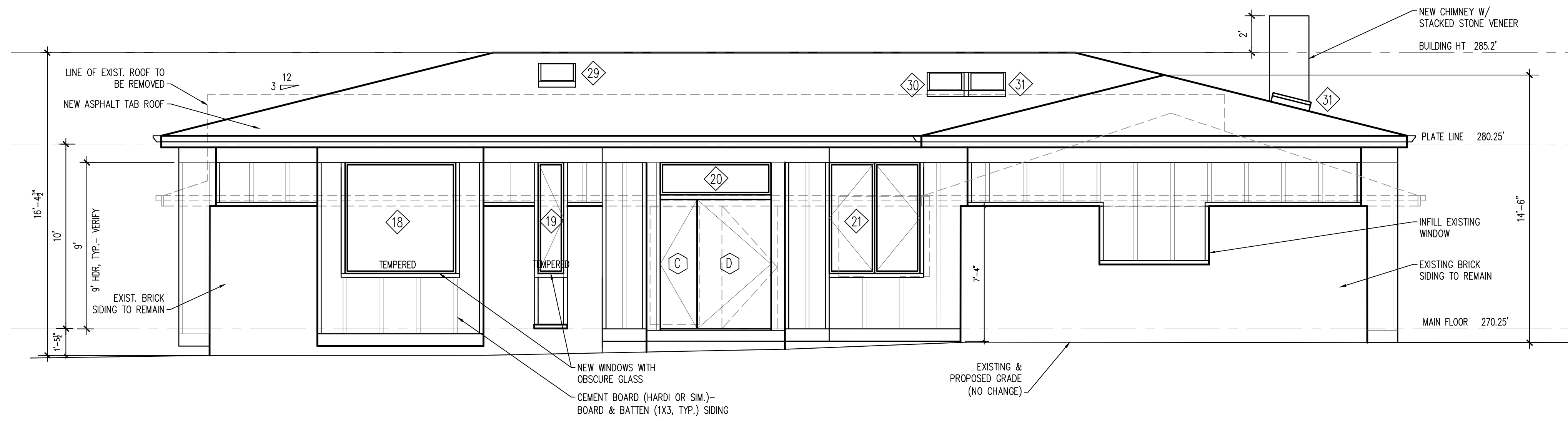

WEST ELEVATION
SEE SHT. A3.2 FOR DOOR SCHEDULE
1/4"=1'-0"

WINDOW SCHEDULE- BASEMENT & MAIN FLOOR

MARK	WINDOW SIZE	OPERATION	MATERIAL	MFGR	GLAZING	U-VALUE	NOTES
1	5'-9" x 4'-2"	FIXED	THERMAL BREAK WOOD CLAD	MARVIN SIGNATURE MODERN	LOW-E, CLR	0.27 MIN	ARGON
2	5'-10" x 4'-2"	FIXED	THERMAL BREAK WOOD CLAD	MARVIN SIGNATURE MODERN	LOW-E, CLR	0.27 MIN	ARGON
3	3'-10" x 4'-2"	FIXED	THERMAL BREAK WOOD CLAD	MARVIN SIGNATURE MODERN	LOW-E, CLR	0.27 MIN	ARGON, TEMPERED MULLED WITH #8
4	3'-10" x 4'-2"	FIXED	THERMAL BREAK WOOD CLAD	MARVIN SIGNATURE MODERN	LOW-E, CLR	0.27 MIN	ARGON, TEMPERED MULLED WITH #9
5	5'-6" x 4'-2"	CSMT	THERMAL BREAK WOOD CLAD	MARVIN SIGNATURE MODERN	LOW-E, CLR	0.28 MIN	ARGON, EGRESS
6	5'-6" x 4'-2"	CSMT	THERMAL BREAK WOOD CLAD	MARVIN SIGNATURE MODERN	LOW-E, CLR	0.28 MIN	ARGON, EGRESS
7	3'-0" x 2'-4"	AWNING	THERMAL BREAK WOOD CLAD	MARVIN SIGNATURE MODERN	LOW-E, CLR	0.28 MIN	ARGON, (E) OPENING
8	3'-10" x 10'-8"	FIXED	THERMAL BREAK WOOD CLAD	MARVIN SIGNATURE MODERN	LOW-E, CLR	0.27 MIN	ARGON, TEMPERED MULLED WITH #3
9	3'-10" x 10'-8"	FIXED	THERMAL BREAK WOOD CLAD	MARVIN SIGNATURE MODERN	LOW-E, CLR	0.27 MIN	ARGON, TEMPERED MULLED WITH #4
10	3'-10" x 10'-8"	FIXED	THERMAL BREAK WOOD CLAD	MARVIN SIGNATURE MODERN	LOW-E, CLR	0.27 MIN	ARGON, TEMPERED
11	3'-10" x 10'-8"	FIXED	THERMAL BREAK WOOD CLAD	MARVIN SIGNATURE MODERN	LOW-E, CLR	0.27 MIN	ARGON, TEMPERED
12	5'-6" x 6'-2"	CSMT	THERMAL BREAK WOOD CLAD	MARVIN SIGNATURE MODERN	LOW-E, CLR	0.28 MIN	ARGON, EGRESS
13	6'-0" x 6'-2"	CSMT	THERMAL BREAK WOOD CLAD	MARVIN SIGNATURE MODERN	LOW-E, CLR	0.28 MIN	ARGON, EGRESS
14	4'-0" x 6'-2"	FIXED	THERMAL BREAK WOOD CLAD	MARVIN SIGNATURE MODERN	LOW-E, CLR	0.27 MIN	ARGON
15	3'-0" x 2'-2"	FIXED	THERMAL BREAK WOOD CLAD	MARVIN SIGNATURE MODERN	LOW-E, CLR	0.27 MIN	ARGON, TRANSOM
16	3'-0" x 2'-2"	FIXED	THERMAL BREAK WOOD CLAD	MARVIN SIGNATURE MODERN	LOW-E, CLR	0.27 MIN	ARGON, TRANSOM
17	3'-0" x 2'-2"	FIXED	THERMAL BREAK WOOD CLAD	MARVIN SIGNATURE MODERN	LOW-E, CLR	0.27 MIN	ARGON, TRANSOM
18	6'-0" x 6'-0"	FIXED	THERMAL BREAK WOOD CLAD	MARVIN SIGNATURE MODERN	LOW-E, OBSCURE	0.27 MIN	ARGON, TEMPERED SANDBLASTED
19	1'-4" x 6'-0"	CSMT	THERMAL BREAK WOOD CLAD	MARVIN SIGNATURE MODERN	LOW-E, OBSCURE	0.28 MIN	ARGON, TEMPERED SANDBLASTED
20	6'-0" x 1'-9"	FIXED	THERMAL BREAK WOOD CLAD	MARVIN SIGNATURE MODERN	LOW-E, CLR	0.27 MIN	ARGON, TRANSOM
21	4'-11" x 6'-0"	CSMT	THERMAL BREAK WOOD CLAD	MARVIN SIGNATURE MODERN	LOW-E, CLR	0.28 MIN	ARGON
22	5'-4" x 1'-6"	FIXED	THERMAL BREAK WOOD CLAD	MARVIN SIGNATURE MODERN	LOW-E, CLR	0.27 MIN	ARGON
23	7'-6" x 1'-9"	FIXED	THERMAL BREAK WOOD CLAD	MARVIN SIGNATURE MODERN	LOW-E, CLR	0.27 MIN	ARGON, TRANSOM
24	3'-0" x 1'-9"	FIXED	THERMAL BREAK WOOD CLAD	MARVIN SIGNATURE MODERN	LOW-E, CLR	0.27 MIN	ARGON, TRANSOM

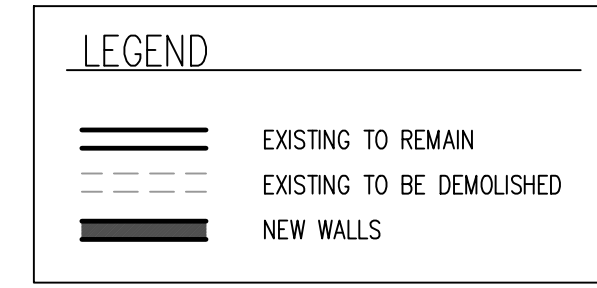

WINDOW SCHEDULE- ROOF

MARK	WINDOW SIZE	OPERATION	MATERIAL	MFGR	GLAZING	U-VALUE	NOTES
25	2'-0" x 4'-0"	SKYLIGHT	ALUMINUM	VELUX	LOW-E, CLR	0.50	ARGON
26	2'-0" x 4'-0"	SKYLIGHT	ALUMINUM	VELUX	LOW-E, CLR	0.50	ARGON
27	2'-0" x 4'-0"	SKYLIGHT	ALUMINUM	VELUX	LOW-E, CLR	0.50	ARGON
28	2'-0" x 4'-0"	SKYLIGHT	ALUMINUM	VELUX	LOW-E, CLR	0.50	ARGON
29	2'-0" x 4'-0"	SKYLIGHT	ALUMINUM	VELUX	LOW-E, CLR	0.50	ARGON
30	2'-0" x 4'-0"	SKYLIGHT	ALUMINUM	VELUX	LOW-E, CLR	0.50	ARGON
31	2'-0" x 4'-0"	SKYLIGHT	ALUMINUM	VELUX	LOW-E, CLR	0.50	ARGON
32	2'-0" x 4'-0"	SKYLIGHT	ALUMINUM	VELUX	LOW-E, CLR	0.50	ARGON

WINDOW GENERAL NOTES:

- ALL WINDOWS TO BE NFRC CERTIFIED.
- CONTRACTOR TO CONFIRM ROUGH OPENING REQUIREMENT W/ MNFR
- WINDOW MFGR TO BE MARVIN SIGNATURE MODERN (VELUX FOR SKYLIGHTS). SCHEDULE ASSUMES ALUMINUM (EBONY FINISH) W/ LOW E 272 GLASS-ARGON. SUBSTITUTIONS ARE ACCEPTABLE AS LONG AS WINDOWS MEET THE ENERGY CODE REQMTS LISTED ON SHEET A1.0
- ALL EXTERIOR WINDOW OPENINGS TO BE WRAPPED W/ VIDAFLX FOR APPROVED EQUAL PEAL & STICK MEMBRANE AND METAL FLASHINGS PER NORTHWEST WALL AND CEILING BUREAU STANDARD DETAILS.
- INSTALL TEMPERED/SAFETY GLAZING AS REQUIRED PER IRC R308 AND NOTED ABOVE.

NO.	REVISION DATE

FORM + FUNCTION ARCHITECTURE
1800 WESTLAKE AVE. N. #205 SEATTLE, WA 98109
206.372.9796

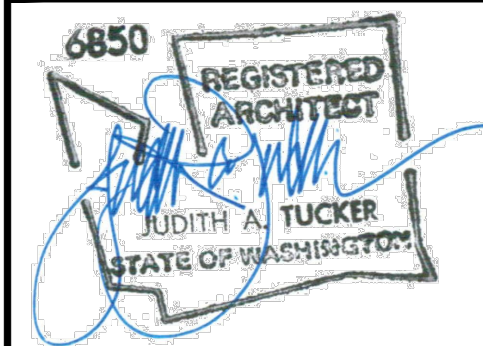

PIPER REMODEL
8429 SE 33RD PL
MERCER ISLAND, WA
98040
PROJECT NO. 1212

DATE 3/4/22
DRAWN BY JT SM
CHECKED BY JT

SHEET TITLE
EXTERIOR ELEV
ROOF PLAN
WINDOW SCHEDULE

SHEET NO.
A3.0

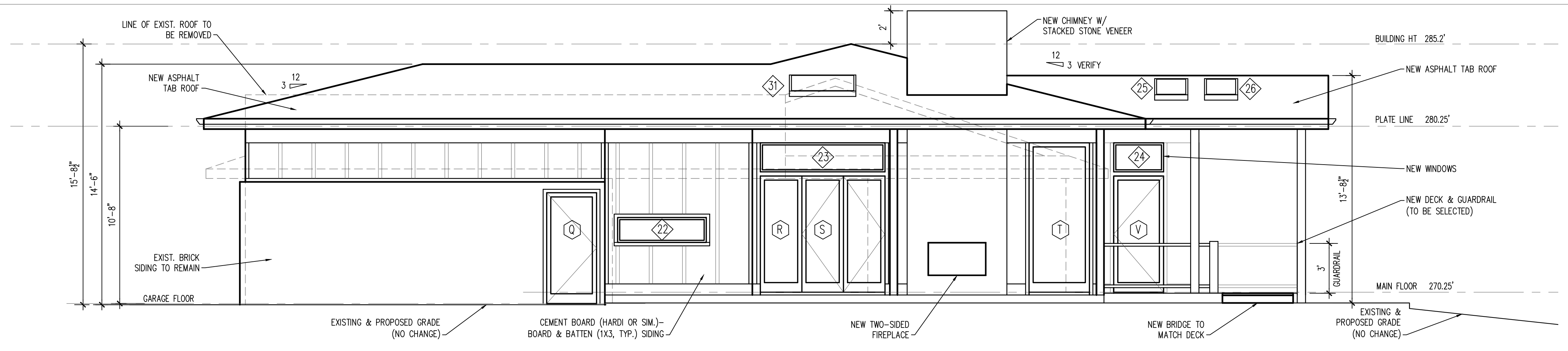

SOUTH ELEVATION

SEE SHT. A3.0 FOR WINDOW SCHEDULE, A3.2 FOR DOOR SCHEDULE

1/4"=1'-0"

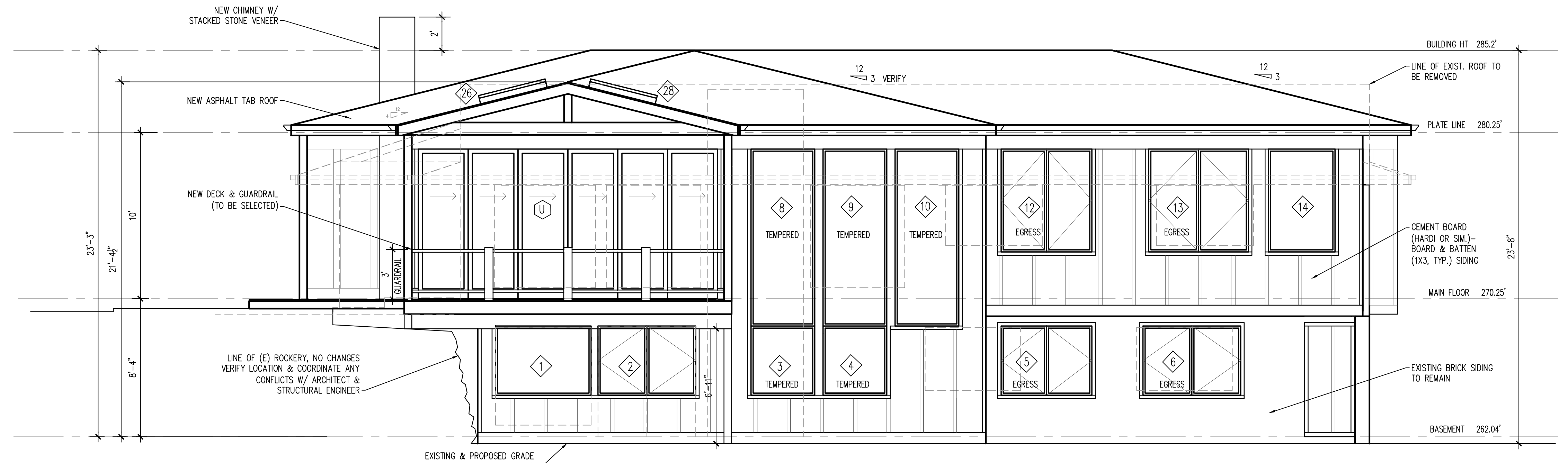

EAST ELEVATION

SEE SHT. A3.0 FOR WINDOW SCHEDULE, A3.2 FOR DOOR SCHEDULE

1/4"=1'-0"

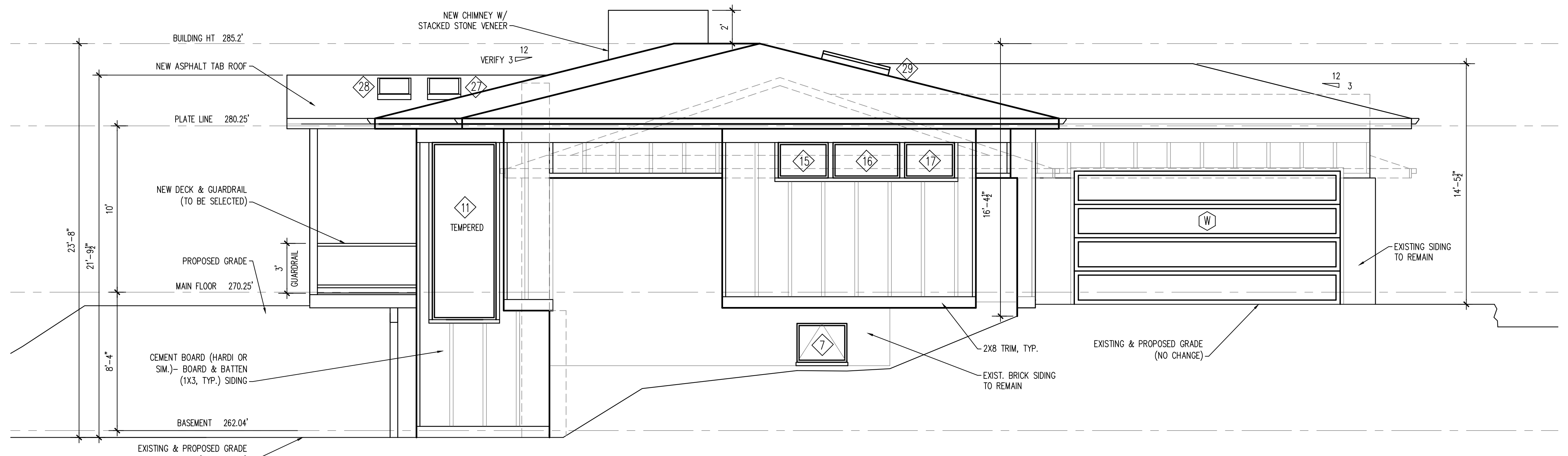

NORTH ELEVATION

SEE SHT. A3.0 FOR WINDOW SCHEDULE, A3.2 FOR DOOR SCHEDULE

1/4"=1'-0"

LEGEND	
	EXISTING TO REMAIN
	EXISTING TO BE DEMOLISHED
	NEW WALLS

STAIR NOTES:

- WIDTH MIN. 36" CLEAR
 - TREAD DEPTH 10" CLEAR (ALLOW FOR 1" OVERHANG - 11" TOTAL)
 - RISER HEIGHT 7 1/2" +/- VERIFY W/ EXISTING GRADE/ FLOOR HEIGHTS (MAX. HT. 7.75")
 - HANDRAIL MIN. 34", MAX 38" ABOVE TREAD NOSINGS
 - HANDRAIL GRASP MIN. 1-1/4", MAX. 2"
 - HANDRAIL PROJECTION MAX. 4-1/2" FROM EACH SIDE OF STAIRWAY INTO REQUIRED WIDTH. MIN. 1-1/2" BETWEEN THE WALL
 - GUARDRAIL MAX OPENING 4" PER SRC R312.1.3
- MIN. UNIFORMLY DISTRIBUTED LIVE LOADS (LBS PER SF)
 200LB CONCENTRATED LOAD ON THE TOP RAIL & 50 PSF ON GUARDRAIL INFILL COMPONENTS PER SRC R301.5-
 SEE STRUCTURAL FOR DETAILS

NO.	REVISION DATE

FORM + FUNCTION ARCHITECTURE
 1800 WESTLAKE AVE. N. #205 SEATTLE, WA 98109
 206.372.9796

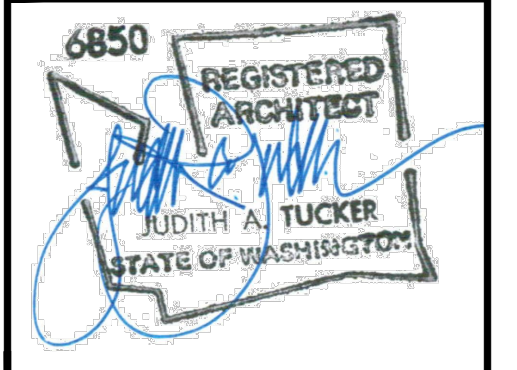

PIPER REMODEL
 8429 SE 33RD PL
 MERCER ISLAND, WA
 98040
 PROJECT NO. 1212

DATE	3/4/22
DRAWN BY	JT SM
CHECKED BY	JT
SHEET TITLE	ELEVATIONS
SHEET NO.	A3.1

A 2022 FORM + FUNCTION

DOOR SCHEDULE- BASEMENT & MAIN FLOOR

MARK	DOOR SIZE W X H	OPERATION	MATERIAL	GLAZING	U-VALUE	NOTES
A	3'-0" x 6'-8"	SWING	GLASS/ SC WOOD	LOW E/ARGON TEMPERED	0.30 MIN	THRESHOLD BY MFRG W/ WEATHERSTRIPPING FOR TIGHT SEAL KEYED LOCK & DEADBOLT (MATCH HOUSE KEY)
B	3'-0" x 6'-8"	SWING	SC WOOD	NA	NA	PRIVACY LATCH
C	2'-0" x 7'-0"	SWING/ FRENCH DR	SC WOOD OR GLASS/ SC WOOD	LOW E/ARGON TEMPERED	0.20 MIN	THRESHOLD BY MFRG W/ WEATHERSTRIPPING FOR TIGHT SEAL-COORD. ASTRIGAL OPTIONS W/ ARCHITECT
D	4'-0" x 7'-0"	SWING/ FRENCH DR	SC WOOD OR GLASS/ SC WOOD	LOW E/ARGON TEMPERED	0.20 MIN	THRESHOLD BY MFRG W/ WEATHERSTRIPPING FOR TIGHT SEAL KEYED LOCK & DEADBOLT (MATCH HOUSE KEY)
E	3'-0" x 6'-8"	POCKET	SC WOOD	NA	NA	
F	2'-8" x 6'-8"	SWING	SC WOOD	NA	NA	PRIVACY LATCH
G	3'-0" x 6'-8"	SWING	SC WOOD	NA	NA	PRIVACY LATCH
H	2'-10" x 6'-8"	SWING	SC WOOD	NA	NA	PRIVACY LATCH
I	NOT USED FOR CLARITY					
J	2'-10" x 6'-8"	POCKET	SC WOOD	NA	NA	PRIVACY LATCH
K	2'-10" x 6'-8"	POCKET	SC WOOD	NA	NA	PRIVACY LATCH
L	2'-10" x 6'-8"	POCKET	SC WOOD	NA	NA	PRIVACY LATCH
M	2'-8" x 6'-8"	POCKET	SC WOOD	NA	NA	PRIVACY LATCH
N	2'-8" x 6'-8"	POCKET	SC WOOD	NA	NA	
O	NOT USED FOR CLARITY					
P	3'-0" x 6'-8"	SWING	SC WOOD	NA	NA	
Q	3'-0" x 6'-8"	SWING	GLASS/ SC WOOD	LOW E/ARGON TEMPERED	0.30 MIN	THRESHOLD BY MFRG W/ WEATHERSTRIPPING FOR TIGHT SEAL
R	2'-6" x 7'-0"	FIXED/ FRENCH DR	GLASS/ SC WOOD	LOW E/ARGON TEMPERED	0.30 MIN	THRESHOLD BY MFRG W/ WEATHERSTRIPPING FOR TIGHT SEAL
S	(2) 2'-6" x 7'-0"	SWING/ FRENCH DR	GLASS/ SC WOOD	LOW E/ARGON TEMPERED	0.30 MIN	THRESHOLD BY MFRG W/ WEATHERSTRIPPING FOR TIGHT SEAL
T	3'-8" x 9'-0"	FIXED/ FRENCH DR	GLASS/ SC WOOD	LOW E/ARGON TEMPERED	0.30 MIN	THRESHOLD BY MFRG W/ WEATHERSTRIPPING FOR TIGHT SEAL
U	(6) 3'-0" x 9'-0"	SLIDER/ FRENCH DR	GLASS/ SC WOOD	LOW E/ARGON TEMPERED	0.30 MIN	THRESHOLD BY MFRG W/ WEATHERSTRIPPING FOR TIGHT SEAL
V	3'-0" x 7'-0"	SWING/ FRENCH DR	GLASS/ SC WOOD	LOW E/ARGON TEMPERED	0.30 MIN	THRESHOLD BY MFRG W/ WEATHERSTRIPPING FOR TIGHT SEAL KEYED LOCK & DEADBOLT (MATCH HOUSE KEY)
W	16'-0" x 8'-0"	GARAGE	OBSOLETE GLASS/ SC WOOD	LOW E/ARGON TEMPERED	0.30 MIN	THRESHOLD BY MFRG W/ WEATHERSTRIPPING FOR TIGHT SEAL

DOOR GENERAL NOTES:

- ALL DOORS TO BE NFRC CERTIFIED.
- CONTRACTOR TO CONFIRM ROUGH OPENING REQUIREMENT W/ MNFR
- ALL INTERIOR & EXTERIOR DOORS BY LOEWEN OR SIMPSON OR EQUIVALENT.
- SET EXTERIOR DOORS IN DOOR PAN PER NORTHWEST WALL & CLG BUREAU STANDARD DETAILS
- ALL EXT. DOOR OPENINGS TO BE WRAPPED W/ VIDAFLEX F OR APPROVED EQUAL PEEL & STICK OR METAL FLASHINGS PER THE NORTHWEST WALL & CLG BUREAU STANDARD DETAILS
- ALL U-VALUES PROVIDED FOR DOORS ARE PRESCRIPTIVE VALUES (MINIMUMS TO BE USED) UNTIL SPECIFIC MANUFACTURERS/DOOR MODELS ARE SELECTED.
- ALL HARDWARE TO BE LEVER TYPE- FINISH TO BE SELECTED.

SEE SHT A3.3 FOR TYPICAL WALL SECTION W/ ADDITIONAL DETAIL

LEGEND

- EXISTING TO REMAIN
- EXISTING TO BE DEMOLISHED
- NEW WALLS

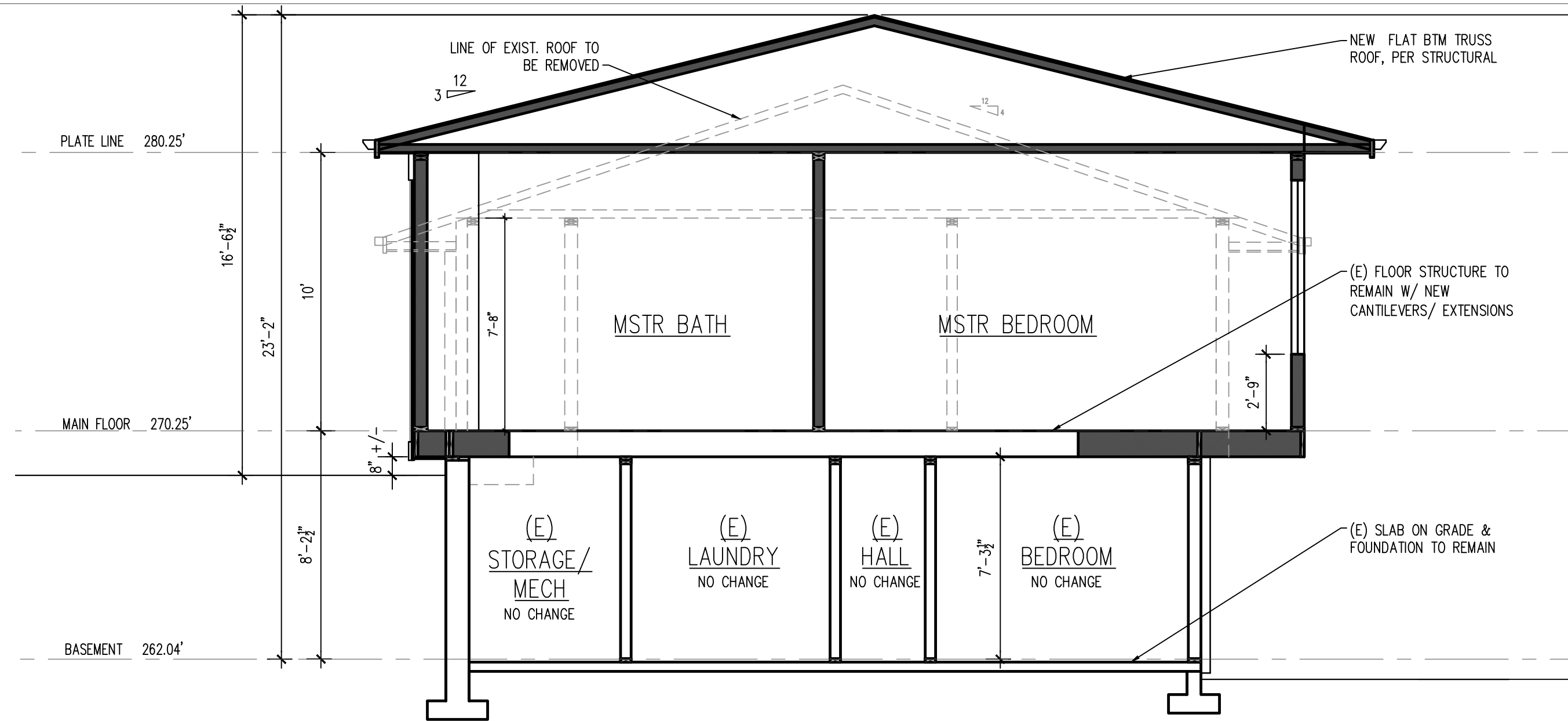

SECTION A-A

VERIFY ALL DIMENSIONS TO EXISTING ELEMENTS

1/4"=1'-0"

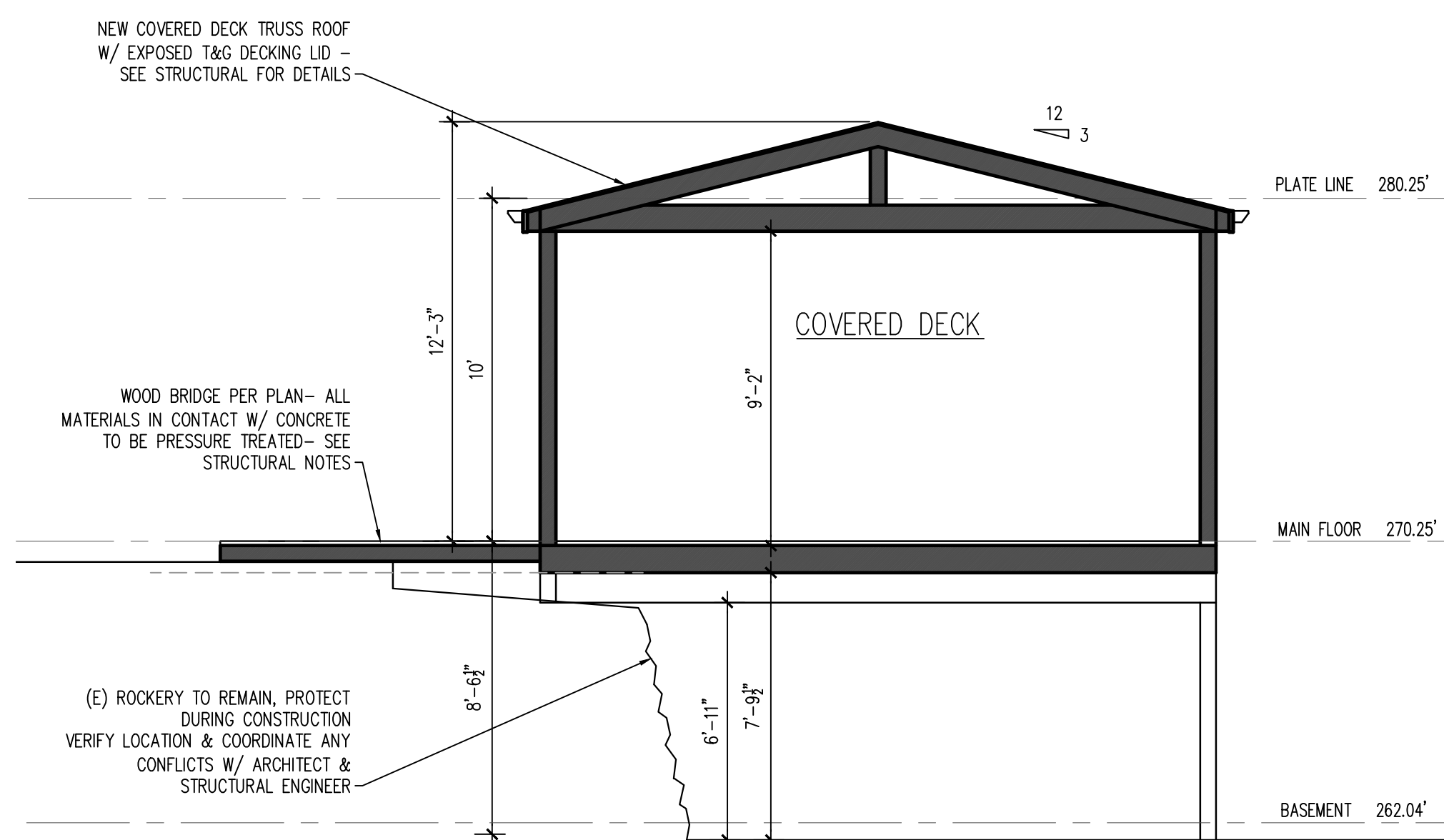

SECTION C-C

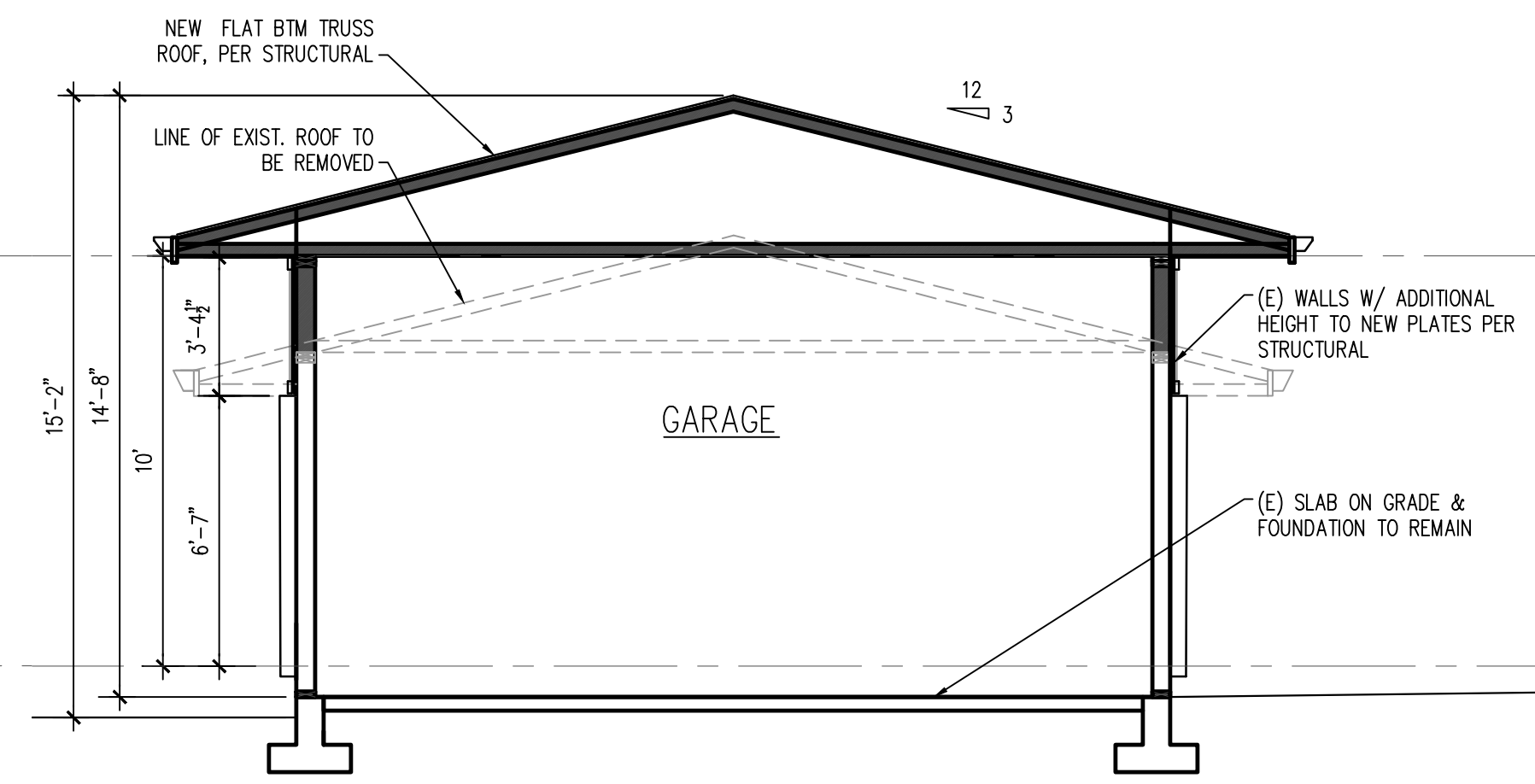

SECTION D-D

1/4"=1'-0"

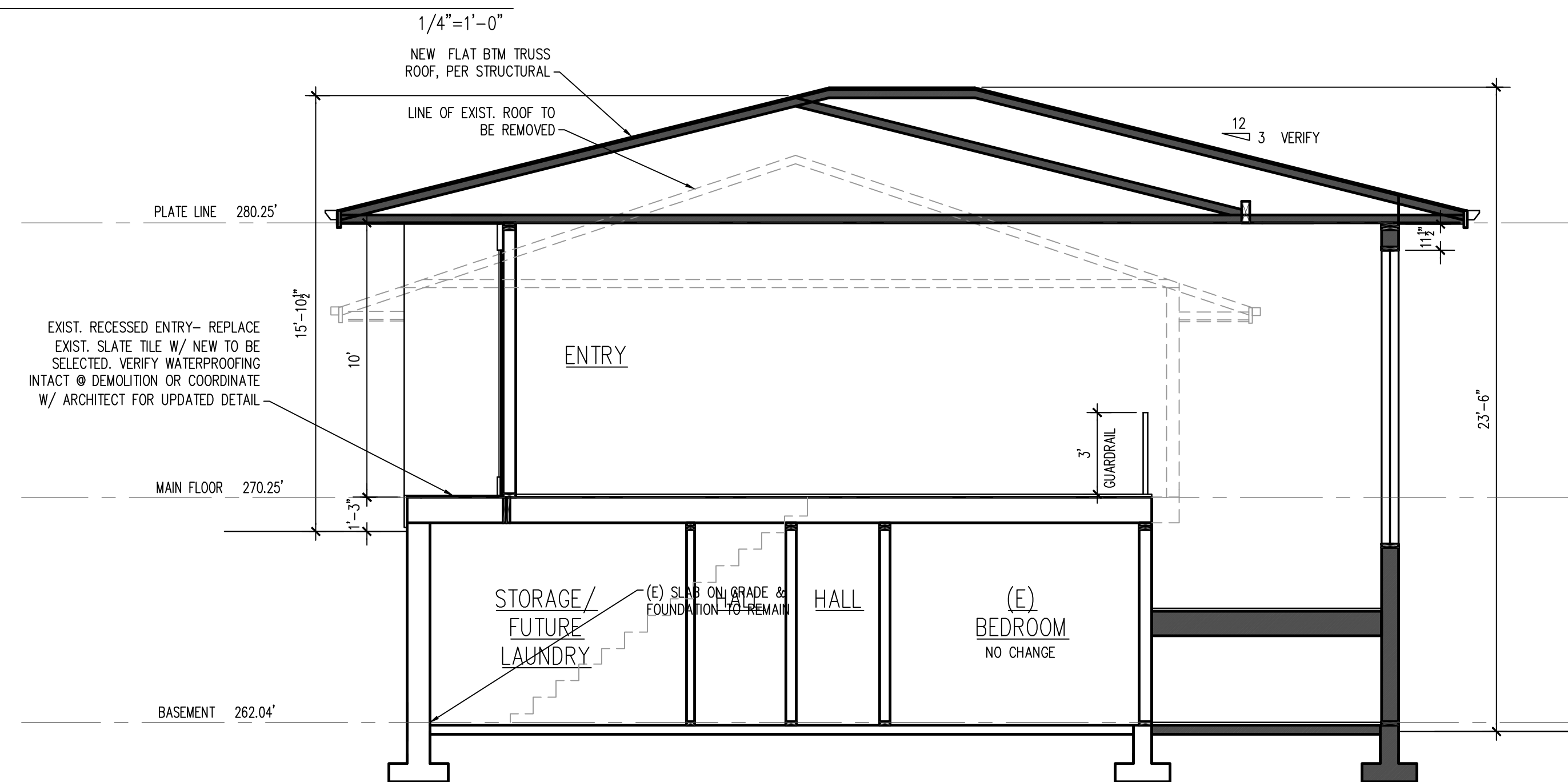

SECTION B-B

VERIFY ALL DIMENSIONS TO EXISTING ELEMENTS

1/4"=1'-0"

NO.	REVISION DATE

FORM + FUNCTION
ARCHITECTURE

1800 WESTLAKE AVE. N. #205 SEATTLE, WA 98109
206.372.9796

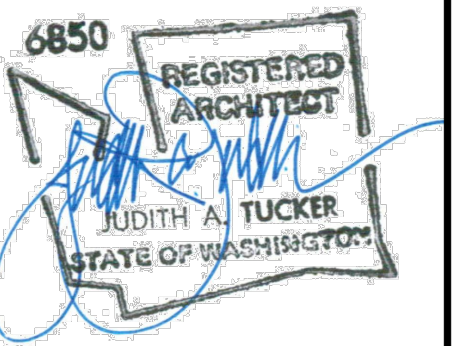

PIPER REMODEL
8429 SE 33RD PL
MERCER ISLAND, WA
98040

PROJECT NO. 1212

DATE	3/4/22
DRAWN BY	JT SM
CHECKED BY	JT

SHEET TITLE
SECTIONS
DOOR SCHEDULE

SHEET NO.
A3.2

LEGEND	
	EXISTING TO REMAIN
	EXISTING TO BE DEMOLISHED
	NEW WALLS

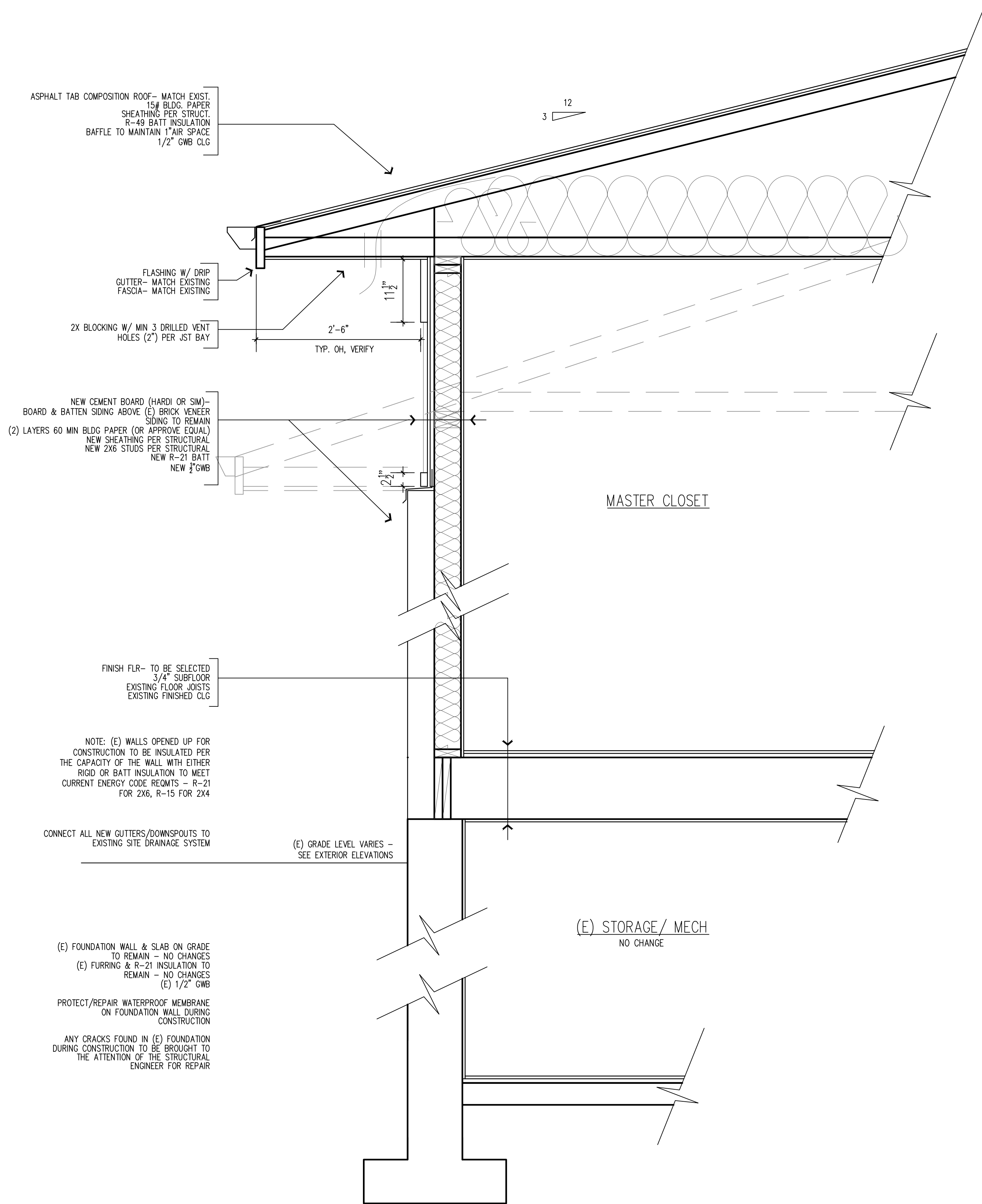

TYP WALL DETAIL

1"=1'-0"

STAIR PLAN

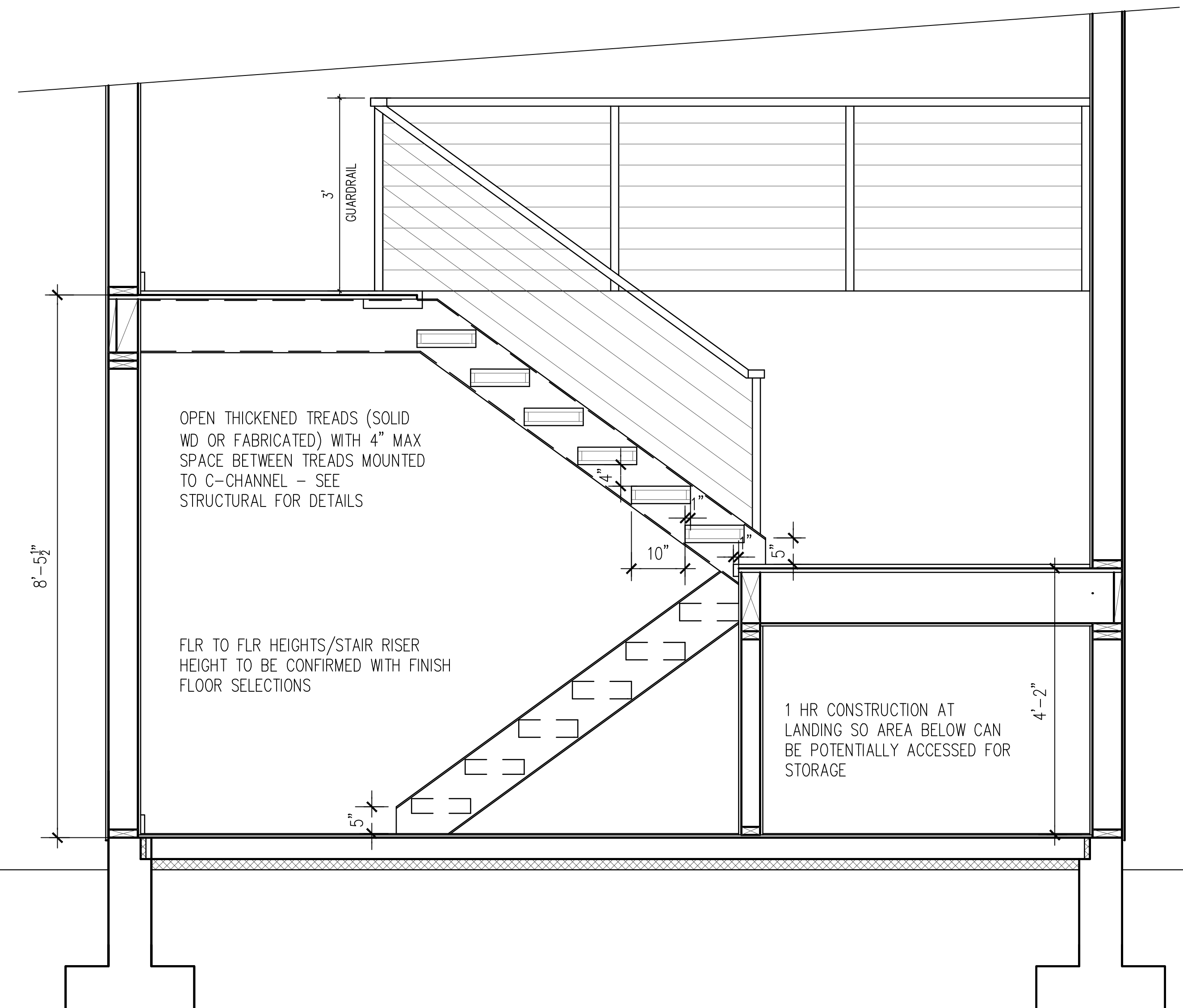
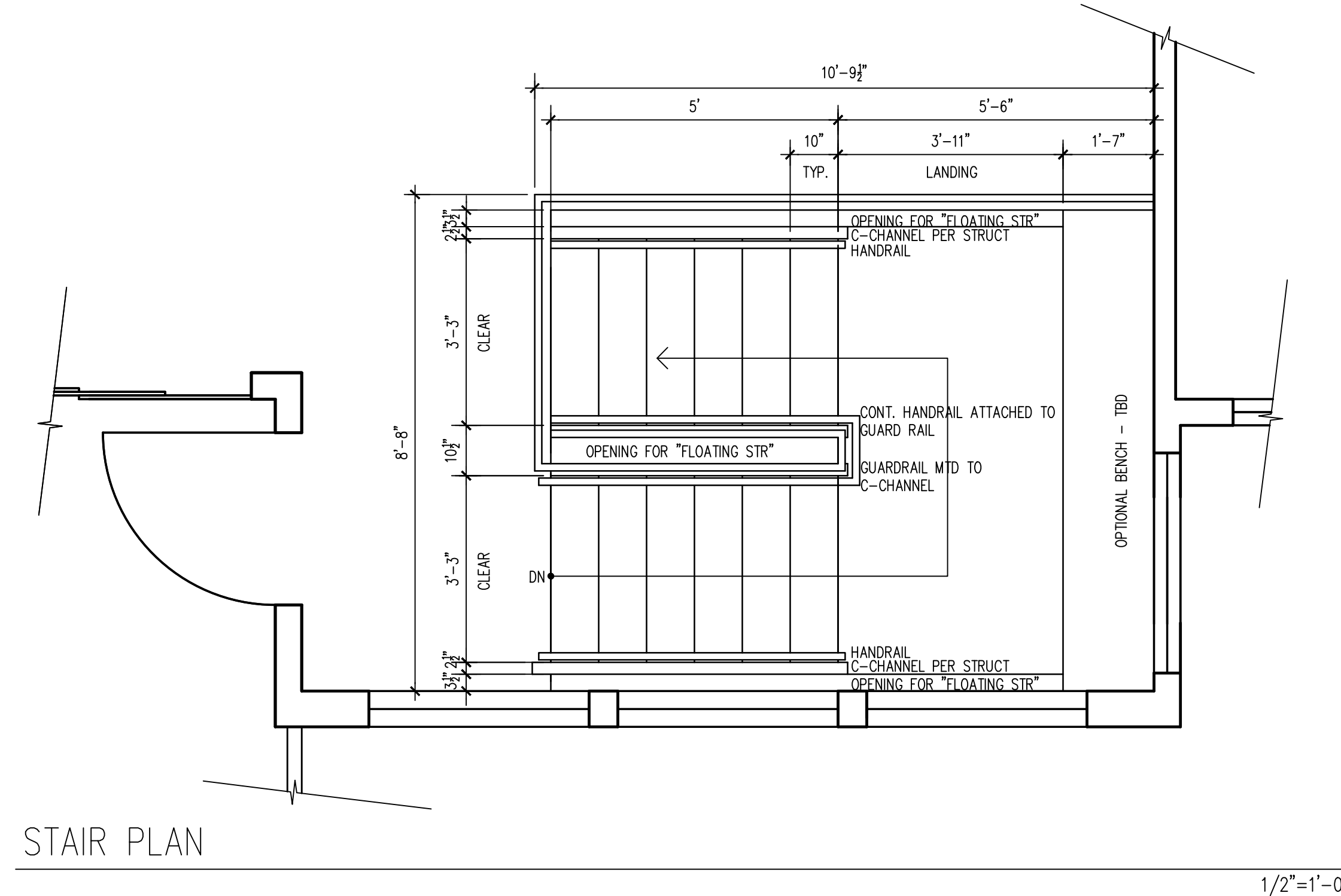

SECTION E-E: NEW STAIR ADDITION

3/4"=1'-0"

NO.	REVISION DATE

FORM + FUNCTION
ARCHITECTURE
1800 WESTLAKE AVE. N. #205 SEATTLE, WA 98109
206.372.9796

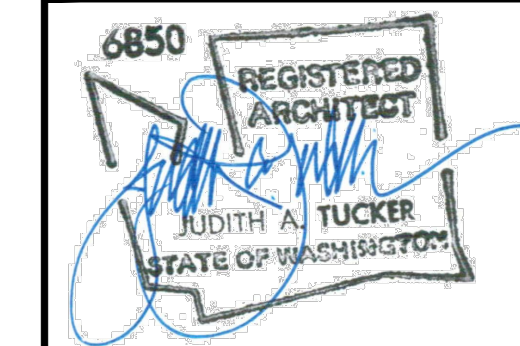

PIPER REMODEL
8429 SE 33RD PL
MERCER ISLAND, WA
98040

PROJECT NO. 1212

DATE 3/4/22
DRAWN BY JT SM
CHECKED BY JT

SHEET TITLE
SECTION E-E
STAIR PLAN
TYP. WALL DETAIL

SHEET NO.
A3.3

01000 - GENERAL REQUIREMENTS
THE STRUCTURAL NOTES SUPPLEMENT THE PLANS AND SPECIFICATIONS. ANY DISCREPANCY FOUND BETWEEN THE DRAWINGS, NOTES, SPECIFICATIONS, SITE CONDITIONS, AND ARCHITECTURAL PLANS SHALL BE REPORTED TO THE ARCHITECT WHO SHALL CORRECT THE DISCREPANCY IN WRITING. ANY WORK COMPLETED AFTER DISCOVERY OF THE DISCREPANCY SHALL BE DONE AT THE CONTRACTOR'S RISK.

THE CONTRACTOR SHALL PROVIDE BRACING AND SUPPORT REQUIRED FOR TEMPORARY CONSTRUCTION LOADS AND FOR STRUCTURAL COMPONENTS AS REQUIRED DURING ERECTION. BACKFILL BEHIND WALLS SHALL NOT BE PLACED UNTIL THE WALLS ARE PROPERLY SUPPORTED.

THE CONTRACTOR SHALL BE RESPONSIBLE FOR COORDINATION OF ALL WORK INCLUDING BUT NOT LIMITED TO EXCAVATION, SHORING, AND OTHER WORK WITH ALL UTILITIES AND ADJACENT PROPERTIES. CALL THE UTILITY LOCATE SERVICE PRIOR TO ANY WORK AT 1-800-424-5555.

01001 - CODE REQUIREMENTS
ALL DESIGN AND CONSTRUCTION SHALL CONFORM TO THE 2018 INTERNATIONAL BUILDING CODE AS ADOPTED BY SEATTLE, WASHINGTON.

01100 - DESIGN LOADS
DEAD LOADS:
ACTUAL WEIGHT OF MATERIALS OF CONSTRUCTION AND PERMANENT EQUIPMENT.

FLOOR LIVE LOADS:
FLOORS (RESIDENTIAL) 40 PSF
DECKS 60 PSF

ROOF LIVE LOADS:
ROOF 20 PSF

SNOW LOAD DESIGN DATA:
Pg = 20 PSF, Pf = 20 PSF, Ce = 0.9, Is = 1.0, Cg = 1.0, 25 PSF UNIFORM

WIND DESIGN DATA:
BASIC WIND SPEED 100 MPH (3-SECOND GUST)
WIND IMPORTANCE FACTOR Iw = 1.0
WIND EXPOSURE EXPOSURE B
TOPOGRAPHICAL FACTOR Kzt = 1.3
INTERNAL PRESSURE COEFFICIENT Gcpi = +/- 0.18
COMPONENT/CLADDING WIND PRESSURE P(C) = 25 PSF

EARTHQUAKE DESIGN DATA:
SEISMIC IMPORTANCE FACTOR Ie = 1.0
OCCUPANCY CATEGORY II
SPECTRAL RESPONSE ACCELERATIONS Ss = 1.401 S1 = 0.487
SITE CLASS D
SPECTRAL RESPONSE COEFFICIENTS SDS = 0.934 SD1 = 0.584
SEISMIC DESIGN CATEGORY D

(E-W) EQUIVALENT LATERAL FORCE - BEARING WALL SYSTEM W/ LIGHT FRAMED WOOD WALLS SHEATHED WITH WOOD STRUCTURAL PANELS RATED FOR SHEAR RESISTANCE
R = 6.5 Cs = 0.14
T = 0.189 (LESS THAN 1.5 Ts) THEREFORE NO SITE RESPONSE ANALYSIS REQUIRED PER ASCE 7-17 SECTION 11.4.8 EXCEPTION #2.

(N-S) COMBINATION OF FRAMING SYSTEMS R = 3.5 Cs = 0.27
IN THE SAME DIRECTION (ASCE 7-16 12.2.3) R = 6.5 WOOD FRAMED SHEAR WALLS, R = 3.5 ORDINARY MOMENT FRAME. GOVERNING R VALUE THIS DIRECTION = 3.5.

01200 - GEOTECHNICAL INVESTIGATION
FOUNDATION DESIGN BASED ON REPORT NO. 2537.01 DATED JANUARY 28, 2022, AND SUPPLEMENTAL REPORT DATED FEBRUARY 28, 2022 PREPARED BY ZIPPER GEO. ALL SITE PREPARATION AND FOUNDATION CONSTRUCTION TO BE PERFORMED PER REPORT. ALL PILE DRIVING TO BE INSPECTED BY A CERTIFIED INSPECTOR WITH LOG CONFIRMING EACH PILE DRIVEN IN ACCORDANCE WITH SOILS REPORT REFUSAL CRITERIA. FILLS TO BE COMPACTED TO 95% MODIFIED PROCTOR PER ASTM D-1557. AND INSTALLED IN LIFTS NO GREATER THEN 10 INCHES. A MINIMUM OF 12 INCHES OF SOIL UNDER NEW INTERIOR AND EXTERIOR SLABS ON GRADE SHALL BE COMPACTED TO 95% MODIFIED PROCTOR PER ASTM D-1557.

ALL FOUNDATIONS SHALL BE COMPACTED ON PIPE PILE OR BY ON AT LEAST MEDIUM DENSE / STIFF NATIVE SOILS OR ABOVE PROPERLY COMPACTED STRUCTURAL FILL OR CDF WITH 100 PSI COMPRESSIVE STRENGTH PLACED ABOVE ADEQUATE NATIVE SOILS PER THE DISCRETION OF THE GEOTECHNICAL ENGINEER. WHERE FOUNDATIONS ARE FOUNDED ATOP CONDITIONS DESCRIBED ABOVE, AN ALLOWABLE NET BEARING CAPACITY OF 2000 PSF HAS BEEN USED FOR DESIGN.

GEOTECHNICAL DESIGN PARAMETERS HAVE BEEN COORDINATED WITH ZIPPER GEO AS LISTED BELOW

DESIGN PARAMETERS ARE AS FOLLOWS:
PASSIVE EARTH PRESSURE 400 PCF (ULTIMATE)
COEFFICIENT OF FRICTION 0.5 (ULTIMATE)
SOIL PROFILE SITE CLASS D

ALL FOUNDATION INSTALLATIONS SHALL BE SUBJECT TO APPROVAL OF THE GEOTECHNICAL ENGINEER.

PIPE PILE
INSTALLATION REQUIREMENTS:
TWO AND THREE INCH DIAMETER PIPE PILE SHALL CONSIST OF PIPE PER ASTM A53 GRADE B AND BE DRIVEN AT LEAST 10 FEET INTO COMPETENT SOIL. PIPE PILE REACHING THE FOLLOWING PENETRATION RATES MAY BE ASSIGNED THE FOLLOWING COMPRESSIVE CAPACITIES. PIPE PILE SHALL BE INSTALLED USING A HYDRAULIC IMPACT HAMMER CARRIED ON LOADS THAT ALLOW THE HAMMER TO SIT ON THE TOP OF THE PILE DURING DRIVING. IF ALTERNATE DRIVING METHODS ARE USED, COORDINATE REQUIRED LOAD TESTS WITH GEOTECHNICAL ENGINEER. GEOTECHNICAL SPECIAL INSPECTOR SHALL BE CONTINUOUSLY PRESENT DURING PIPE PILE INSTALLATION. (F.D.R. - FINAL DRIVING RATE):

Table with 5 columns: PILE DIAMETER, PERCUSSION DRIVER, F.D.R. 90 LB, F.D.R. 650 LB, ALLOWABLE COMP CAPACITY. Rows include 2 INCH (X-STRONG) SCHEDULE 80, 3 INCH (STANDARD) SCHEDULE 40, and 4 INCH (E) 4 INCH.

FIELD TESTING REQUIREMENTS:
LOAD TESTS ARE NOT REQUIRED FOR TWO OR THREE INCH DIAMETER PIPE PILES THAT ARE DRIVEN IN ACCORDANCE WITH THE RECOMMENDATIONS PRESENTED IN JANUARY 28, 2022 REPORT PREPARED BY ZIPPER GEO, AND PROVIDED THAT A ZGA REPRESENTATIVE OBSERVES INSTALLATION OF THE PILES AND VERIFIES THAT REFUSAL HAS BEEN ACHIEVED.

01300 - SHOP DRAWING SUBMITTAL PROCESS
SHOP DRAWINGS ARE TO BE SUBMITTED TO THE ARCHITECT AND ENGINEER OF RECORD FOR APPROVAL PRIOR TO FABRICATION. IF SHOP DRAWINGS DIFFER FROM THE APPROVED DESIGN DRAWINGS, NEW DESIGN DRAWINGS BEARING THE SEAL AND SIGNATURE OF A LICENSED STATE OF WASHINGTON STRUCTURAL ENGINEER SHALL BE SUBMITTED ALONG WITH THE SHOP DRAWINGS TO THE BUILDING OFFICIAL FOR APPROVAL PRIOR TO FABRICATION.

SHOP DRAWINGS ARE REQUIRED FOR STRUCTURAL STEEL AND PROPRIETARY GUARD COMPONENT.

01400 - INSPECTIONS AND SPECIAL INSPECTIONS
THE CONTRACTOR SHALL BE RESPONSIBLE TO COORDINATE ALL INSPECTIONS REQUIRED BY THE LOCAL BUILDING DEPARTMENT.

SPECIAL INSPECTIONS ARE NOT REQUIRED FOR GROUP R-3 OCCUPANCIES UNLESS OTHERWISE REQUIRED BY THE BUILDING OFFICIAL.

01600 - QUALITY ASSURANCE REQUIREMENTS
QUALITY ASSURANCE PLAN SHALL BE TO VERIFY THAT THE SPECIAL INSPECTIONS NOTED IN SECTION 01400 AND THE STRUCTURAL OBSERVATION NOTED IN SECTION 01500 HAVE BEEN COMPLETED AND THAT SUPPORTING DOCUMENTATION NOTED IN SUCH SECTIONS HAS BEEN PROVIDED.

QUALITY ASSURANCE PLAN IS NOT REQUIRED FOR STRUCTURES OF LIGHT WOOD FRAMING WITH DESIGN SPECTRAL RESPONSE AT SHORT PERIODS, SDS, NOT EXCEEDING 0.50g.

QUALITY ASSURANCE PLAN IS NOT REQUIRED FOR WIND EXPOSURE B WHERE BASIC WIND SPEED IS LESS THAN 120 MPH.

SUMMARY: A QUALITY ASSURANCE PLAN IS NOT REQUIRED BY CODE FOR THIS STRUCTURE.

01700 - EXECUTION REQUIREMENTS
INSTALLATION OF ALL STRUCTURAL COMPONENTS SHALL BE AS REQUIRED PER ALL LOCAL CODES.

02000 - SITE CONSTRUCTION
ALL SITE CONSTRUCTION SHALL BE CONSISTENT WITH THE GEOTECHNICAL ENGINEERING RECOMMENDATIONS AS NOTED IN THE GEOTECHNICAL ENGINEERING REPORT (SEE SECTION 01200) AND IN SUBSEQUENT DIRECTIVES.

02100 - EXCAVATION SUPPORT AND PROTECTION
EXCAVATION FOR FOUNDATIONS SHALL BE PER PLAN DOWN TO UNDISTURBED NATIVE MATERIAL PER THE GEOTECHNICAL ENGINEERING RECOMMENDATIONS. OVER-EXCAVATED AREAS SHALL BE BACKFILLED WITH LEAN CONCRETE OR PER GEOTECHNICAL RECOMMENDATIONS AT THE CONTRACTOR'S EXPENSE.

EXCAVATION SLOPES SHALL BE SAFE AND SHALL NOT BE GREATER THAN THE LIMITS SPECIFIED BY LOCAL, STATE, AND NATIONAL SAFETY REGULATIONS.

02200 - BACKFILL AND COMPACTION
BACKFILL SHALL NOT BE PLACED UNTIL THE REMOVAL OF FORMWORK AND OF ANY DEBRIS. BACKFILL BEHIND ALL WALLS SHALL NOT BE PLACED UNTIL THE WALLS ARE PROPERLY SUPPORTED. ALL BACKFILL MATERIAL AND PLACEMENT PROCEDURES SHALL BE CONSISTENT WITH THE GEOTECHNICAL ENGINEERING RECOMMENDATIONS.

03000 - CAST-IN-PLACE CONCRETE
CONCRETE CONSTRUCTION SHALL CONFORM TO THE AMERICAN CONCRETE INSTITUTE STANDARD ACI 318-14 "BUILDING CODE REQUIREMENTS FOR STRUCTURAL CONCRETE".

CEMENT AND CONCRETE SHALL CONFORM TO IBC SECTION 1903. ADMIXTURES SHALL BE APPROVED BY THE ENGINEER OF RECORD AND SHALL COMPLY WITH ACI 318-14 SECTION 3.6. CONCRETE EXPOSED TO FREEZING AND THAWING SHALL HAVE AN AIR ENTRAINING ADMIXTURE CONFORMING TO IBC SECTION 1904.2. THE USE OF WATER SOLUBLE CHLORIDE ION SHALL NOT BE USED.

CONCRETE MIX DESIGNS SHALL MEET THE FOLLOWING REQUIREMENTS:
(1) 28 DAY MAX. STRENGTH Fc [PSI] (2) MAX. WATER / CEMENT RATIO (3) MAX. SLUMP [IN] (4) AIR ENTRAINMENT [%] (5) SPECIAL INSPECTION REQUIRED (6) MIN. 90 LB SACKS OF CEMENT (7) LOCATION AND APPLICATION.

Table with 7 columns: (1) through (7) and rows for 3000, 3000, 3000, 3000, 3000 concrete grades and their properties.

SPECIAL INSPECTION IS NOT REQUIRED AS THE DESIGN IS BASED ON Fc = 2500 PSI.

CHAMFER ALL EXPOSED CORNERS PER THE ARCHITECTURAL PLANS OR 3/4 INCH IF NOT SPECIFIED BY THE ARCHITECT.

03100 - REINFORCING STEEL
REINFORCING STEEL DETAILING, FABRICATION, AND PLACEMENT SHALL BE PER ACI 318-14. REINFORCING STEEL SHALL MEET THE FOLLOWING REQUIREMENTS:

ASTM A-615 DEFORMED BARS GRADE 40 (fy=40 KSI) FOR #3 BARS ONLY
ASTM A-615 DEFORMED BARS GRADE 60 (fy=60 KSI) FOR #4 BARS AND LARGER
ASTM A-706 DEFORMED BARS GRADE 60 (fy=60 KSI) FOR ALL WELDABLE BARS
ASTM A-1064 SMOOTH BAR (fy=60 KSI) FOR WELDED WIRE FABRIC

REINFORCING FOR SLABS ON GRADE SHALL BE 6X6 W1.4XW1.4 WELDED WIRE FABRIC OR FIBER MESH UNLESS NOTED OTHERWISE. PROVIDE LAP SPLICES PER THE LAP SPLICE SCHEDULE ON SHEET S6.0.

COVER REQUIREMENTS SHALL BE AS FOLLOWS UNLESS NOTED OTHERWISE:

CONCRETE CAST AGAINST EARTH
ALL BAR SIZES ... 3"
FORMED SURFACE EXPOSED TO EARTH OR WEATHER
#6 AND LARGER ... 2"
#5 AND SMALLER ... 1 1/2"
CONCRETE NOT EXPOSED TO EARTH OR WEATHER WALLS AND JOISTS
#14 AND #18 BARS ... 1 1/2"
#11 BARS AND SMALLER ... 3/4"
SLABS AND JOISTS
#14 AND #18 BARS ... 1 1/2"
#11 BARS AND SMALLER ... 1"
BEAMS, COLUMNS
PRIMARY REINFORCEMENT ... 1 1/2"
TIES, STIRRUPS, AND SPIRALS ... 1 1/2"

REINFORCING STEEL SHALL BE ACCURATELY PLACED AND ADEQUATELY SECURED IN PLACE PRIOR TO CONCRETE PLACEMENT. REINFORCING STEEL SHALL NOT BE FIELD BENT EXCEPT AS NOTED IN THE DESIGN DRAWINGS. WELDING OF REINFORCING STEEL SHALL NOT BE PERMITTED WITHOUT PRIOR APPROVAL OF THE ENGINEER OF RECORD EXCEPT AS NOTED ON THE DESIGN DRAWINGS.

03200 - CONCRETE WALL REINFORCING
PLACE TWO HORIZONTAL #5 BARS AT EACH FLOOR LEVEL OR TOP OF WALL ELEVATION. PROVIDE CORNER BARS TO MATCH HORIZONTAL REINFORCEMENT AT EACH WALL CORNER AND INTERSECTION. PROVIDE TWO VERTICAL #5 BARS AT EACH WALL CORNER AND INTERSECTION. AT ALL WALL OPENINGS PROVIDE TWO #5 BARS OVER, UNDER, AND AT THE SIDES OF THE OPENINGS. EXTEND THE HORIZONTAL BARS THE LAP SPLICE DISTANCE PAST THE OPENING OR EXTEND AS FAR AS POSSIBLE AND HOOK. PROVIDE ONE #5 BAR BY 4'-0" LONG DIAGONALLY AT EACH CORNER OF THE WALL OPENING. ALL CONCRETE SHALL BE PLACED AND CONSOLIDATED WALLS SHALL BE REINFORCED PER SCHEDULE BELOW U.N.O.:

Table with 4 columns: WALL THICKNESS, HORIZONTAL, VERTICAL, LOCATION. Rows include 6", 10", 12" wall thicknesses and their reinforcement details.

EPOXY ALL HORIZONTAL STEEL INTO EXISTING FOUNDATION WITH FOUR INCH EMBEDMENT. RE: NOTES SECTION 08100 FOR EPOXY TYPE.

05000 - STRUCTURAL STEEL
DESIGN, FABRICATION, AND ERECTION OF STRUCTURAL STEEL SHALL BE IN ACCORDANCE WITH THE LATEST EDITION OF THE AMERICAN INSTITUTE OF STEEL CONSTRUCTION "AISC 360-10 SPECIFICATION FOR STRUCTURAL STEEL BUILDINGS". MATERIALS SHALL BE IN ACCORDANCE WITH THE FOLLOWING U.N.O.:

Table with 3 columns: STRUCTURAL W SHAPE, ASTM A-992, Fy = 50 KSI. Rows include S, M, AND C SHAPES, STEEL ANGLES, PLATE MATERIAL, STRUCTURAL PIPE, STRUCTURAL HSS, ANCHOR RODS, WOOD CONNECTION BOLTS, WELDING ELECTRODES.

ALL WELDING SHALL CONFORM TO THE AWS D1.4 "STRUCTURAL WELDING CODE". ALL WELDING SHALL BE PERFORMED BY A WASHINGTON ASSOCIATION OF BUILDING OFFICIALS (WABO) AND AMERICAN WELDING SOCIETY (AWS) CERTIFIED WELDERS. ALL COMPLETE PENETRATION (CP) WELDS SHALL BE ULTRASONICALLY TESTED. ALL FILLET WELDS SHALL BE VISUALLY INSPECTED RE: S1.1.

STRUCTURAL STEEL AND CONNECTIONS EXPOSED TO WEATHER SHALL BE HOT DIPPED GALVANIZED AFTER FABRICATION IN COMPLIANCE WITH ASTM A-123. ALL FIELD WELDS EXPOSED TO WEATHER SHALL BE COATED WITH BRUSH APPLIED ZINC-RICH PAINT COMPLYING WITH ASTM A-780.

ALL STRUCTURAL STEEL TO RECEIVE ONE COAT OF PAINT (PRIME COAT). PROVIDE A MINIMUM FRY-FILM THICKNESS OF ONE MIL. PREPARE SURFACE TO MEET REQUIREMENTS OF SSPC-SP2. TOUCHUPS OF ABRASIONS ARE THE RESPONSIBILITY OF THE CONTRACTOR. U.N.O. REFER TO ARCHITECTURAL DRAWINGS AND SPECIFICATIONS FOR ADDITIONAL INFORMATION RELATING TO FINISH PAINT OR OTHER FINISH REQUIREMENTS.

06000 - WOOD FRAMING NOTES
FRAMING CONNECTORS, ACCESSORIES, AND FASTENERS AS NOTED IN THE PLANS AND DETAILS SHALL BE AS MANUFACTURED BY SIMPSON STRONG-TIE. EQUIVALENT HARDWARE MAY BE USED WITH PRIOR APPROVAL BY ENGINEER OF RECORD. INSTALL ALL HARDWARE PER MANUFACTURERS SPECIFICATIONS. WHERE STRAPS CONNECT TWO MEMBERS TOGETHER, PLACE HALF OF THE REQUIRED FASTENERS INTO EACH MEMBER. PROVIDE SOLID BLOCKING AT ALL BEARING POINTS. SEE SECTION 06100 FOR FASTENER REQUIREMENTS AT TREATED LUMBER. TYPICAL NAILING NOT SHOWN FOR PLAN, DETAIL, OR SCHEDULE. SHALL CONFORM TO FASTENING SCHEDULE PER IBC TABLE 2304.10.1 OR TO THE FASTENING SCHEDULE ON SHEET S9.0.

NAILS SHALL BE COMMON UNLESS NOTED OTHERWISE COMMON NAIL DIMENSIONS ARE AS FOLLOWS:
NAIL SIZE DIAMETER LENGTH
8d 0.131" 2 1/2"
10d 0.148" 3"
12d 0.148" 3 1/4"
16d 0.162" 3 1/2"

UNLESS NOTED OTHERWISE PER SHEARWALL SCHEDULE OR PLANS, ANCHOR BOLTS AT SILL PLATES SHALL BE 5/8 INCH DIAMETER WITH 7 INCHES MINIMUM EMBEDMENT INTO CONCRETE AND SHALL BE SPACED NOT MORE THAN 4 FEET APART. THERE SHALL BE A MINIMUM OF TWO BOLTS PER SILL PIECE WITH ONE BOLT LOCATED NOT MORE THAN 12 INCHES NOR LESS THAN 4 1/2 INCHES FROM EACH END OF THE PIECE. A 3"x3"x1/4" PLATE WASHER SHALL BE PROVIDED FOR ALL ANCHOR BOLTS (COUNTERSINK PLATE WASHERS SHALL NOT BE ALLOWED).

06100 - ROUGH FRAMING
SAWN LUMBER SHALL CONFORM TO WEST COAST LUMBER SCHEDULE BUREAU (WCLIB) "GRADING AND DRESSING RULES" NO. 17 LATEST EDITION. SAWN LUMBER SHALL BE S4S AND SURFACED DRIED, 19 PERCENT MAXIMUM MOISTURE CONTENT. PROTECT LUMBER FROM WEATHER AND PROVIDE FURTHER DRYING OF ASSEMBLED FRAMING TO MINIMIZE WOOD SHRINKAGE POTENTIAL. ALL LUMBER EXPOSED TO WEATHER OR IN CONTACT WITH CONCRETE OR MASONRY SHALL BE PRESERVATIVE TREATED U.N.O. PER PLAN. LUMBER SPECIES, GRADE, AND PROPERTIES FOR EACH USE/LOCATION SHALL BE AS FOLLOWS U.N.O. PER PLANS/SCHEDULE:

Table with 6 columns: USE/LOCATION, SPECIES, GRADE, Fb (PSI), Fv (PSI), Fcp (PSI), Fc (PSI), E (PSI). Rows include WALL STUDS/BLOCKING 2X, 3X 4" WIDE and 2X, 3X 6" WIDER.

Table with 6 columns: WALL PLATES, SPECIES, GRADE, Fb (PSI), Fv (PSI), Fcp (PSI), Fc (PSI), E (PSI). Rows include 2X4, 3X4 and 2X6, 3X6.

Table with 6 columns: JOISTS, SPECIES, GRADE, Fb (PSI), Fv (PSI), Fcp (PSI), Fc (PSI), E (PSI). Rows include 2X, 3X.

Table with 6 columns: LEDGERS, SPECIES, GRADE, Fb (PSI), Fv (PSI), Fcp (PSI), Fc (PSI), E (PSI). Rows include 2X, 3X and 4X.

Table with 6 columns: BEAMS AND POSTS, SPECIES, GRADE, Fb (PSI), Fv (PSI), Fcp (PSI), Fc (PSI), E (PSI). Rows include 4X and 6X.

06200 - PRESERVATIVE TREATED WOOD PRODUCTS
PRESERVATIVE TREATED WOOD SHALL BE REQUIRED FOR ALL WOOD THAT FORMS THE STRUCTURAL SUPPORT OF THE BUILDING, BALCONIES PORCHES, OR SIMILAR PERMANENT BUILDING APPURTENANCES THAT ARE EXPOSED TO THE WEATHER WITHOUT ADEQUATE PROTECTION FROM A ROOF, EAVE, OVERHANG OR OTHER COVERING TO PREVENT MOISTURE OR WATER ACCUMULATION AT THE SURFACE OR AT JOINTS BETWEEN MEMBERS.

ALL WOOD INSTALLED ABOVE GROUND AND RESTING ON AN EXTERIOR CONCRETE OR MASONRY FOUNDATION WALL LESS THAN 8 INCHES FROM EXPOSED EARTH.

POSTS OR COLUMNS SUPPORTING PERMANENT STRUCTURES AND SUPPORTED BY A CONCRETE SLAB OR FOOTING THAT IS IN DIRECT CONTACT WITH THE EARTH, EXCEPT:

- 1. IF LOCATED IN BASEMENTS ON A CONCRETE PIER OR METAL PEDESTAL 1 INCH ABOVE THE SLAB AND SEPARATED THEREFROM BY AN IMPERVIOUS MOISTURE BARRIER.
2. IF IN AN ENCLOSED CRAWL SPACE OR AN UNEXCAVATED AREA WITHIN THE BUILDING PERIPHERY AND SUPPORTED BY A CONCRETE PIER OR PEDESTAL MORE THAN 8 INCHES FROM EXPOSED GROUND AND SEPARATED THEREFROM BY AN IMPERVIOUS MOISTURE BARRIER.
3. SLEEPERS AND SILLS ON A CONCRETE SLAB ON GRADE THAT DOES NOT HAVE AN IMPERVIOUS MOISTURE BARRIER SEPARATION WITH EXPOSED EARTH.
4. LEDGERS AND FURRING ATTACHED DIRECTLY TO THE INTERIOR OF EXTERIOR CONCRETE OR MASONRY WALLS BELOW GRADE.

PRESERVATIVE TREATMENT SHALL BE PER AMERICAN WOOD PRESERVERS' ASSOCIATION (AWPA) SPECIFICATION C2 AND C9 OR APPLICABLE STANDARDS.

ALL FASTENERS (NAILS, BOLTS, ANCHOR BOLTS, PLATES, HANGERS, ETC.) IN CONTACT WITH TREATED LUMBER SHALL BE CORROSION RESISTANT G-185 HOT DIPPED GALVANIZED PER ASTM A153 OR STAINLESS STEEL.

06300 - JOIST AND BEAM HANGERS
JOIST AND BEAM HANGERS AS NOTED IN THE PLANS SHALL BE AS MANUFACTURED BY SIMPSON STRONG-TIE. EQUIVALENT HARDWARE MAY BE USED WITH PRIOR APPROVAL BY ENGINEER OF RECORD. JOIST AND BEAM HANGERS SHALL BE INSTALLED PER MANUFACTURERS' SPECIFICATIONS AND SHALL BE AS FOLLOWS UNLESS NOTED OTHERWISE PER PLANS OR DETAILS:

Table with 3 columns: MEMBER SIZE, HANGER, LUS OR HUS SERIES TO MATCH LUMBER SIZE WHERE NOT NOTED SPECIFICALLY BELOW. Rows include GLUED LAMINATED BEAMS (3 1/8" to 10 3/4") and LSL (1 1/2" x 11 7/8" to 3 1/2" x 11 7/8").

PROVIDE HUC HANGER FOR BEAM SIZE SPECIFIED FOR END OF BEAM CONDITIONS.

06400 - SHRINKAGE OF WOOD FRAMING
SHRINKAGE IN WOOD FRAMING IS DUE TO LOSS OF MOISTURE CONTENT AND TO COMPRESSION OF ASSEMBLIES OF WOOD COMPONENTS. PLUMBING, ELECTRICAL, AND MECHANICAL SYSTEMS AS WELL AS EXTERIOR FINISHES SHALL BE DESIGNED AND BUILT TO ACCOMMODATE 1/4 INCH PER FLOOR WOOD SHRINKAGE. THE USE OF KILN DRIED LUMBER AND PROVIDING A DRYING PROCESS TO THE FRAMING MEMBERS PRIOR TO APPLICATION OF FINISHES WILL HELP CONTROL BUT WILL NOT ELIMINATE SHRINKAGE.

06500 - WOOD SHEATHING
STRUCTURAL WOOD SHEATHING PANELS SHALL HAVE APA GRADE TRADEMARK OF THE AMERICAN PLYWOOD ASSOCIATION. WOOD SHEATHING PANELS SHALL BE C-D INT APA WITH EXTERIOR GLUE (CDX). ORIENTED STRAND BOARD (OSB) PANELS SHALL BE EXPOSURE 1. PANELS SHALL HAVE THE FOLLOWING THICKNESS, SPAN RATING, AND FASTENING UNLESS NOTED OTHERWISE PER PLAN:

Table with 3 columns: ROOF, FLOOR, SHEARWALL, EXTERIOR WALL. Rows include 5/8" 40/20 C-D APA CDX, 3/4" 48/24 C-D T&G, 7/16" C-D EXTERIOR GLUE, 7/16" D-D EXTERIOR GLUE.

ALL ROOF SHEATHING PANELS SHALL BE INSTALLED FACE GRAIN PERPENDICULAR TO SUPPORTS AND IN A STAGGERED PATTERN UNLESS NOTED OTHERWISE PER PLAN. BLOCKING AT INTERMEDIATE FLOOR AND ROOF SHEATHING JOINTS SHALL NOT BE REQUIRED UNLESS NOTED OTHERWISE PER PLAN. SHEARWALL SHEATHING SHALL BE BLOCKED AT ALL EDGES WITH 2X OR 3X FRAMING PER SHEARWALL SCHEDULE.

Table with 4 columns: SHEET, DESCRIPTION, Rev, Rev Date. Rows include S1.0 Structural Notes, S1.1 Shearwall Schedule and Details, S1.2 Holddown Schedule and Details, S2.0 Basement Level Walls Over Foundation, S2.1 Main Frmng Over Basement Lvl Shear Walls, S2.2 Roof Framing Over Main Level Shear Walls, S6.0 Typical Concrete Details, S8.0 Moment Frame Details, S8.1 Moment Frame Details, S8.2 Moment Frame Details, S8.3 Moment Frame Details, S9.0 Typical Wood Framing Details, S9.1 Typical Wood Framing Details, S9.2 Typical Wood Framing Details, S10.0 Typical Components.

06510 - SHOP FABRICATED METAL PLATE CONNECTED WOOD TRUSSES
PREMANUFACTURED METAL-PLATE-CONNECTED WOOD TRUSSES SHALL BE DESIGNED AND MANUFACTURED IN ACCORDANCE WITH IBC SECTION 2303.4 TRUSSES, AND THE TRUSS PLATE INSTITUTE ANSITP1-2007 "NATIONAL DESIGN STANDARD FOR METAL-PLATE-CONNECTED WOOD TRUSS CONSTRUCTION". A TRUSS SUBMITTAL PACKAGE SHALL BE SUBMITTED FOR APPROVAL PRIOR TO FABRICATION PER THE REQUIREMENTS OF IBC 2303.4.2. THE TRUSS DESIGN DRAWINGS SHALL BEAR THE STAMP AND SEAL OF A REGISTERED STATE OF WASHINGTON PROFESSIONAL ENGINEER.

DESIGN FOR THE SPANS, LOADS, SHAPES, BEARING POINTS, INTERSECTIONS, HIPS AND VALLEYS, OVER-FRAMING, BLOCKING PANELS AND ALL CONDITIONS SHOWN ON THE PLANS. THE DESIGN LOADS AND DEFLECTION CRITERIA SHALL BE AS FOLLOWS:

Table with 2 columns: TOP CHORD LOADS, BOTTOM CHORD LOADS. Rows include TOP CHORD LIVE LOAD, TOP CHORD DEAD LOAD, TOP CHORD GROSS WIND UPLIFT, OVERHANGS AT CORNERS, CORNERS, OVERHANG AT EDGE, EDGES, FIELD, TOP CHORD NET WIND PRESSURE ABOVE PRESSURES LESS.

Table with 2 columns: DEFLECTION LIMITATIONS, LIVE LOAD DEFLECTION, TOTAL LOAD DEFLECTION. Rows include LIVE LOAD DEFLECTION L/720, TOTAL LOAD DEFLECTION L/480.

PROVIDE ALL TRUSS-TO-TRUSS CONNECTION DETAILS INCLUDING BLOCKING PANELS AND REQUIRED MATERIALS. PROVIDE EACH TRUSS WITH THE STRUCTURAL BUILDING COMPONENT (SBC) TAGS FOR BEARING LOCATIONS, PERMANENT BRACING LOCATIONS ETC. THE TRUSS DESIGNER SHALL SPECIFY ALL PERMANENT BRACING LOCATIONS & TRUSS REACTIONS ON THE TRUSS DESIGN DRAWINGS.

STORE, INSTALL & BRACE TRUSSES IN ACCORDANCE WITH WTCATPI (SBCA) BUILDING COMPONENT SAFETY INFORMATION (BCSI) "GUIDE TO GOOD PRACTICE FOR HANDLING, INSTALLING & BRACING OF METAL-PLATED-WOOD TRUSSES" & BCSI B1 THROUGH B11 QUICK REFERENCES. THE CONTRACTOR SHALL INSTALL ALL TEMPORARY BRACING, SEE BCSI-2 FOR TYPICAL TEMPORARY BRACING REQUIREMENTS.

THE CONTRACTOR SHALL INSTALL ALL PERMANENT BRACING AS INDICATED ON THE TRUSS DESIGN DRAWINGS AND PLANS. REFERENCE BCSI-B3 FOR TYPICAL PERMANENT BRACING REQUIREMENTS U.N.O.

MINIMUM BEARING FOR TRUSSES SHALL BE 3 1/2". SECURE TRUSSES TO TOP PLATE WITH (2) 0.148" DIAMETER x 3" TOE NAILED, ONE EACH SIDE. AS A MINIMUM PROVIDE #2.5A HURRICANE CLIP AT EACH SUPPORT OF TRUSS.

06620 - STRUCTURAL GLUED LAMINATED TIMBER
GLUED-LAMINATED MEMBERS SHALL HAVE AMERICAN INSTITUTE OF TIMBER CONSTRUCTION (AITC) IDENTIFICATION MARK. EXPOSED MEMBERS SHALL RECEIVE ONE COAT OF END SEALER APPLIED IMMEDIATELY AFTER TRIMMING IN EITHER SHOP OR FIELD. DESIGN MATERIAL PROPERTIES SHALL BE AS FOLLOWS:

Table with 4 columns: USE, COMBINATION SYMBOL, SPECIES, CAMBER. Rows include SIMPLE SPAN BEAM, CONTINUOUS BEAM, CANTILEVER BEAM.

UNEXPOSED GLUED-LAMINATED TIMBER SHALL BE INDUSTRIAL GRADE. TYPICAL, UNLESS NOTED OTHERWISE. EXPOSED GLUED LAMINATED TIMBER SHALL BE APPEARANCE CLASS PER ARCHITECT.

06630 - STRUCTURAL COMPOSITE LUMBER (SCL)
STRUCTURAL COMPOSITE LUMBER SHALL CONFORM TO ALL PERTINENT PROVISIONS OF ASTM D4546 AND SHALL BE THE SIZE AND TYPE SHOWN ON THE DRAWINGS AS MANUFACTURED BY LEVEL TRUS JOIST OR APPROVED EQUAL. STORAGE, ERECTION, AND INSTALLATION SHALL BE PER MANUFACTURER SPECIFICATIONS. ALL MEMBERS SHALL NOT HAVE NOTCHES OR DRILLED HOLES WITHOUT PRIOR ENGINEER OF RECORD APPROVAL. ALLOWABLE DESIGN MATERIAL PROPERTIES SHALL BE AS FOLLOWS (ALL UNITS ARE IN PSI):

Table with 5 columns: ORIENTATION, Fb, Fv, Fc(perp), Fc, E. Rows include TIMBERSTRAND LAMINATED STRAND LUMBER (LSL) COLUMNS, PLANK, BEAM, RIM and MICROLAM LAMINATED VENEER LUMBER (LVL) BEAM.

08100 - EPOXY ADHESIVE ANCHORS
CONCRETE
EPOXY SPECIFIED IN THE DRAWINGS SHALL BE SIMPSON STRONG-TIE SET-XP EPOXY ADHESIVE. ANCHOR ROD, THREADED ROD, OR REINFORCING DIAMETER AND EMBEDMENT PER PLAN. INSTALLATION PER ESR-2506.

08200 - EXPANSION ANCHORS
CONCRETE
EXPANSION ANCHORS SPECIFIED IN THE DRAWINGS SHALL BE SIMPSON STRONG-TIE STRONG-BOLT WEDGE ANCHOR. ANCHOR DIAMETER AND EMBEDMENT PER PLAN. INSTALLATION PER SECTION 4.3 OF ESR-1771.

08300 - SCREW ANCHORS
CONCRETE
SCREW ANCHORS SPECIFIED IN THE DRAWINGS SHALL BE SIMPSON STRONG-TIE TITEN HD. ANCHOR DIAMETER AND EMBEDMENT PER PLAN. INSTALLATION PER ESR-2713.

Table with 4 columns: SHEET, DESCRIPTION, Rev, Rev Date. Rows include S1.0 Structural Notes, S1.1 Shearwall Schedule and Details, S1.2 Holddown Schedule and Details, S2.0 Basement Level Walls Over Foundation, S2.1 Main Frmng Over Basement Lvl Shear Walls, S2.2 Roof Framing Over Main Level Shear Walls, S6.0 Typical Concrete Details, S8.0 Moment Frame Details, S8.1 Moment Frame Details, S8.2 Moment Frame Details, S8.3 Moment Frame Details, S9.0 Typical Wood Framing Details, S9.1 Typical Wood Framing Details, S9.2 Typical Wood Framing Details, S10.0 Typical Components.

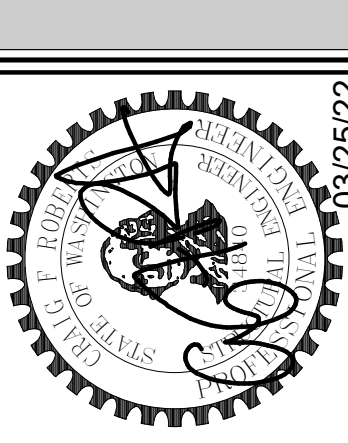

Table with 2 columns: REVISION, DATE. Includes a grid for tracking changes.

Table with 2 columns: JOB #, 21162; ENG: BJM; CAD: JMA; SCALE: 3/8" = 1'-0"; KEY ISSUE DATES: SD, CD, PD, PERMIT, OTHER.

Table with 2 columns: JOB #, 21162; ENG: BJM; CAD: JMA; SCALE: 3/8" = 1'-0"; KEY ISSUE DATES: SD, CD, PD, PERMIT, OTHER.

08100 - EPOXY ADHESIVE ANCHORS
CONCRETE
EPOXY SPECIFIED IN THE DRAWINGS SHALL BE SIMPSON STRONG-TIE SET-XP EPOXY ADHESIVE. ANCHOR ROD, THREADED ROD, OR REINFORCING DIAMETER AND EMBEDMENT PER PLAN. INSTALLATION PER ESR-2506.

08200 - EXPANSION ANCHORS
CONCRETE
EXPANSION ANCHORS SPECIFIED IN THE DRAWINGS SHALL BE SIMPSON STRONG-TIE STRONG-BOLT WEDGE ANCHOR. ANCHOR DIAMETER AND EMBEDMENT PER PLAN. INSTALLATION PER SECTION 4.3 OF ESR-1771.

08300 - SCREW ANCHORS
CONCRETE
SCREW ANCHORS SPECIFIED IN THE DRAWINGS SHALL BE SIMPSON STRONG-TIE TITEN HD. ANCHOR DIAMETER AND EMBEDMENT PER PLAN. INSTALLATION PER ESR-2713.

Structural Notes
PIPER REMODEL
8429 SE 33RD PLACE
MERCER ISLAND, WA 98040

S1.0

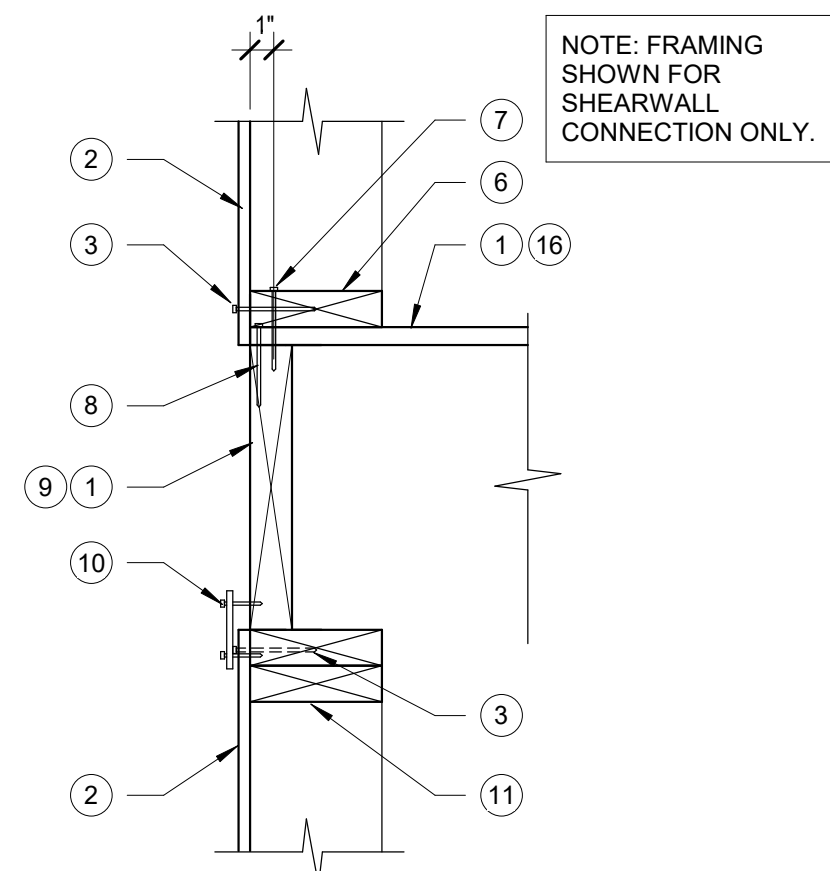

SCALE: 3/4" = 1'-0"
1 TYP. EXT./ELEV./STAIR WALL SHEAR CONN.

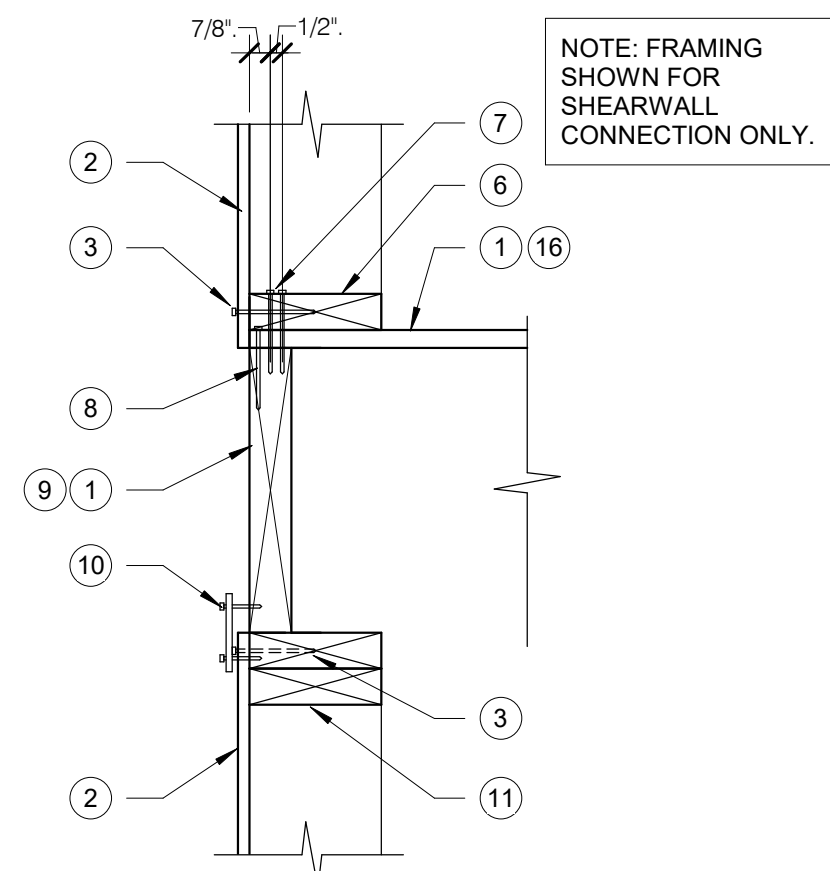

SCALE: 3/4" = 1'-0"
2 TYP. EXT./ELEV./STAIR WALL SHEAR CONN.

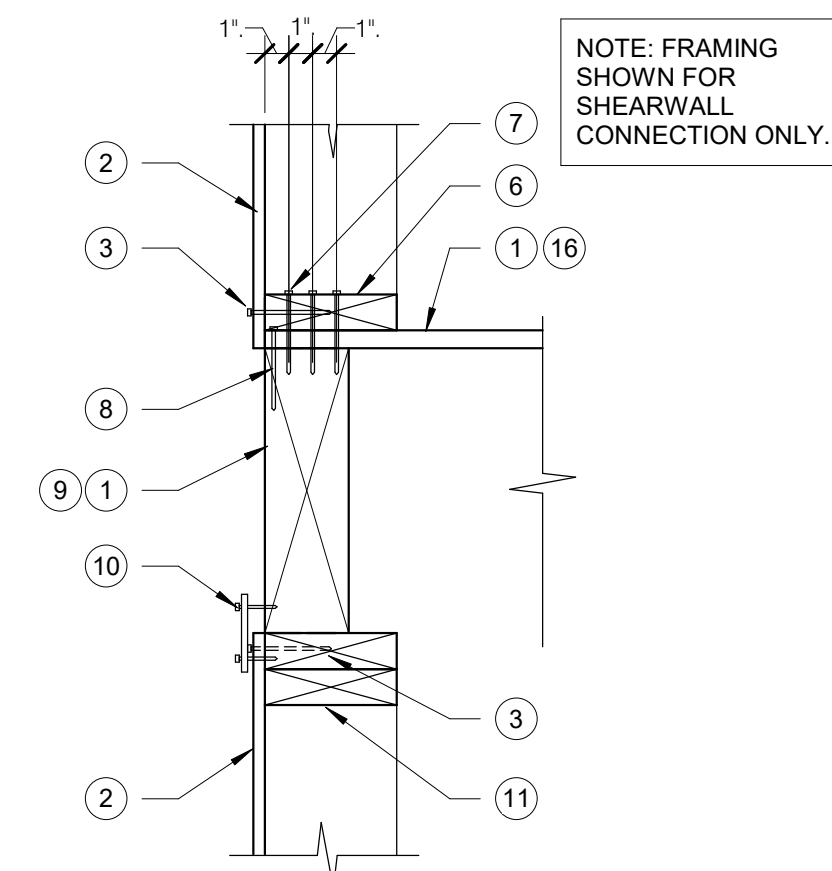

SCALE: 3/4" = 1'-0"
3 TYP. EXT./ELEV./STAIR WALL SHEAR CONN.

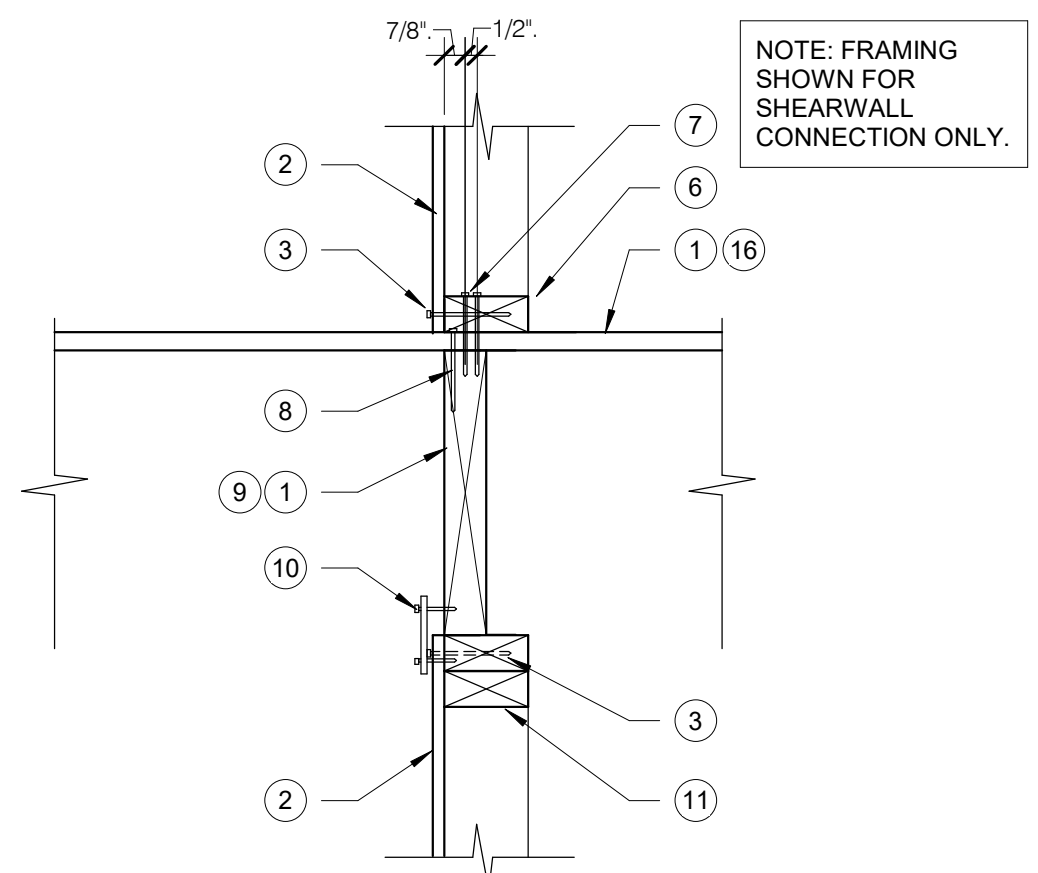

SCALE: 3/4" = 1'-0"
6 TYP. EXT./ELEV./STAIR WALL SHEAR CONN.

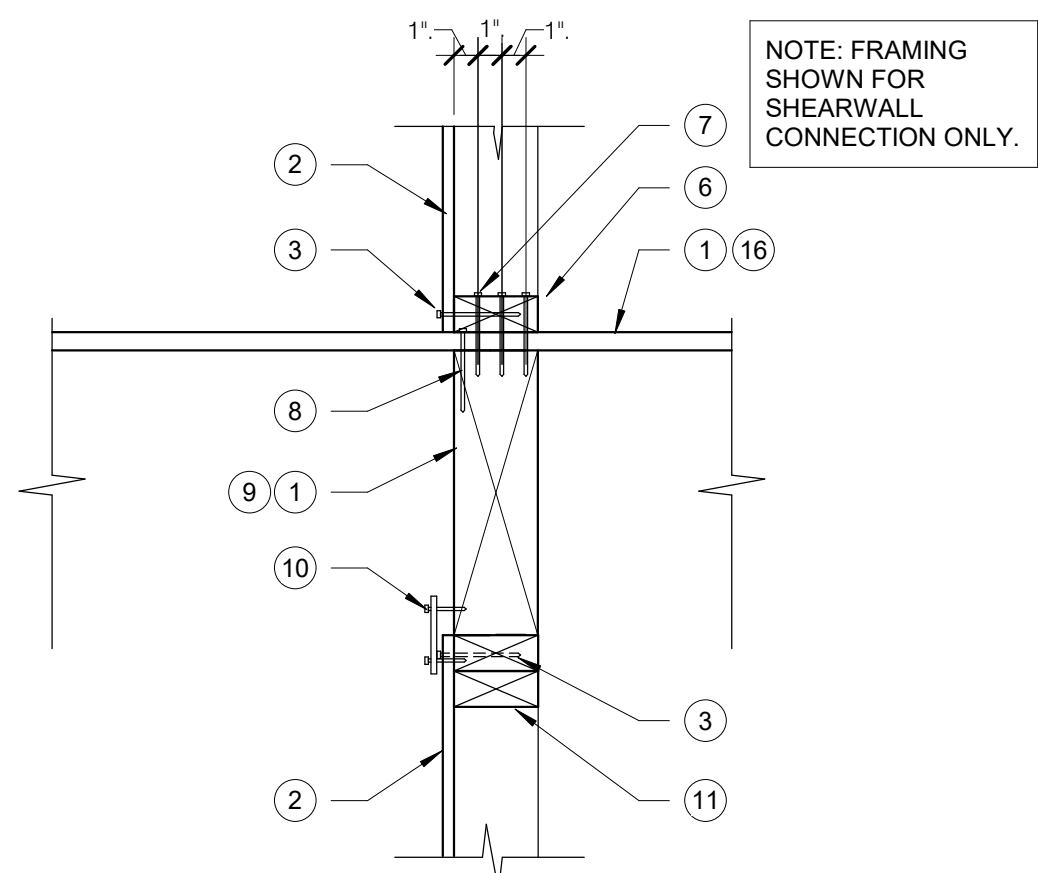

SCALE: 3/4" = 1'-0"
7 TYP. EXT./ELEV./STAIR WALL SHEAR CONN.

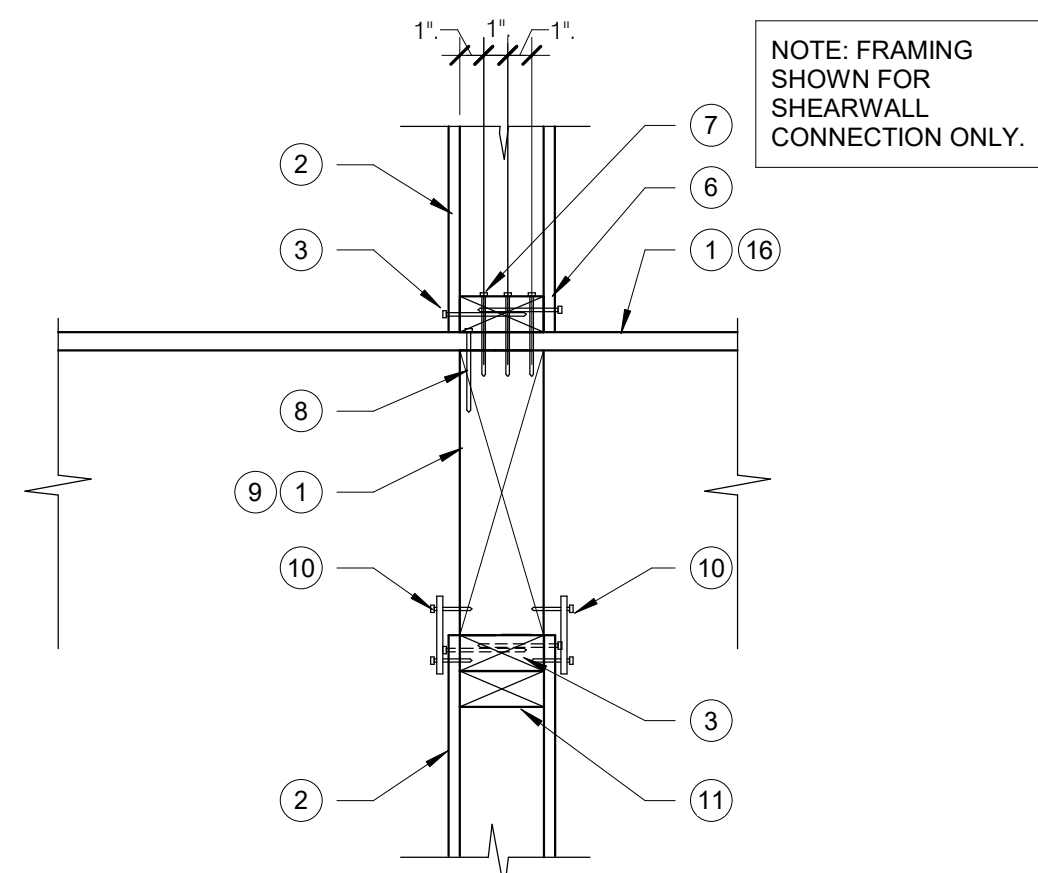

SCALE: 3/4" = 1'-0"
8 TYP. EXT./ELEV./STAIR WALL SHEAR CONN.

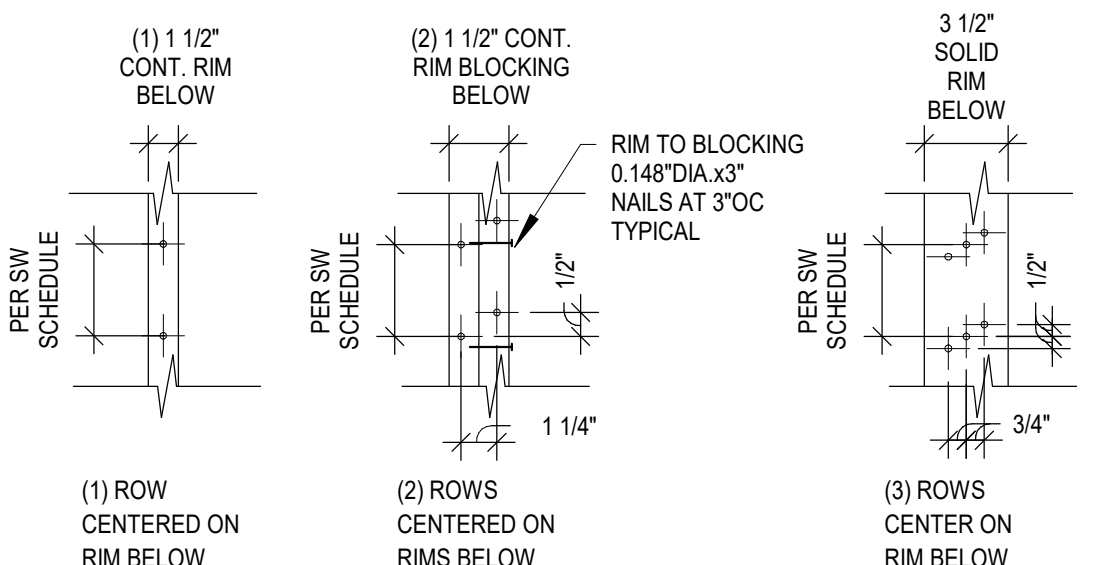

SCALE: NONE
11 BOTTOM PLATE NAILING PATTERN

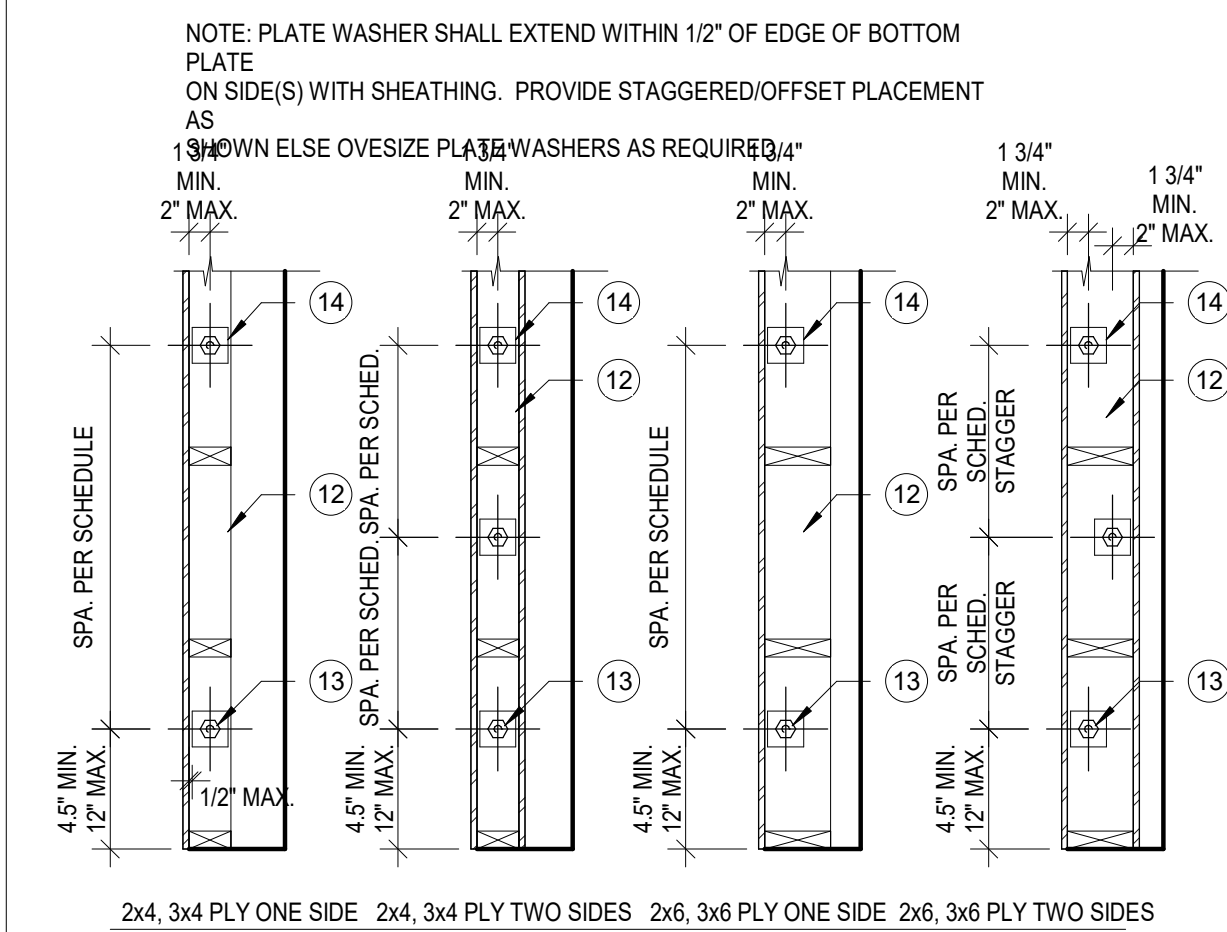

SCALE: 3/4" = 1'-0"
12 ANCHOR BOLT PLACEMENT DETAILS

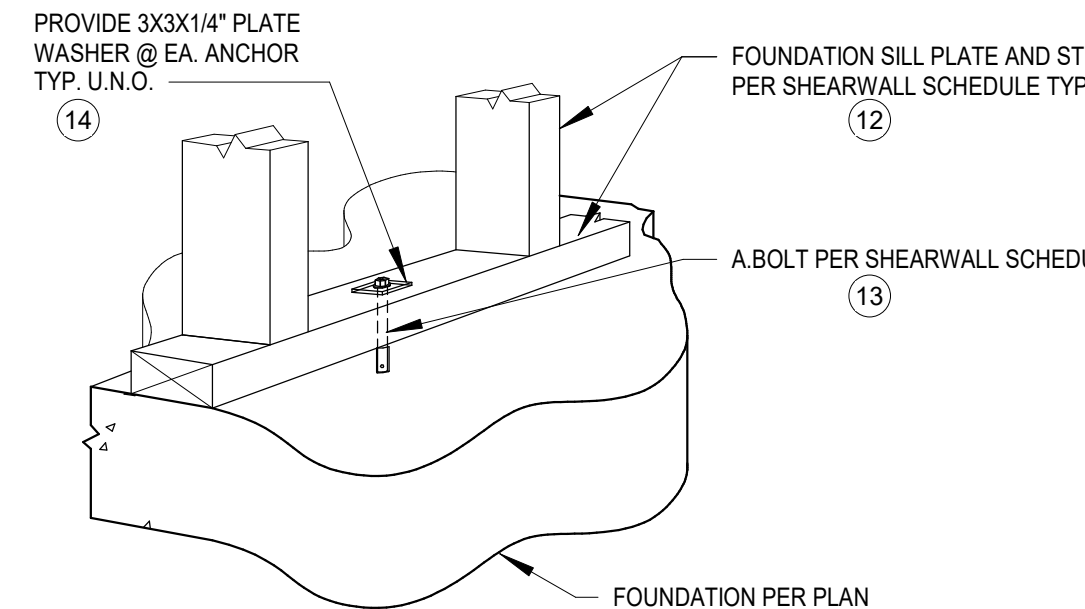

SCALE: 3/4" = 1'-0"
13 TYP. SHEARWLL ANCHOR BOLT TO CONCRETE

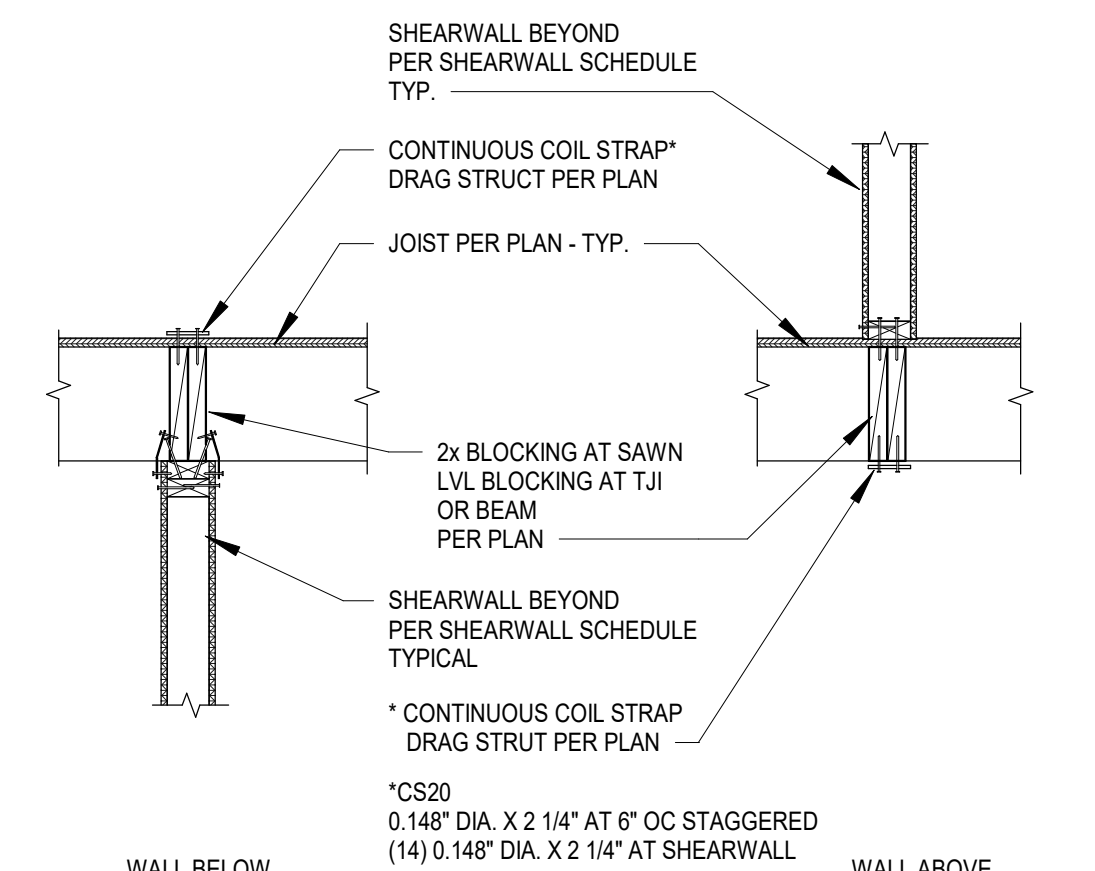

SCALE: 3/4" = 1'-0"
16 DRAG STRUT DETAILS

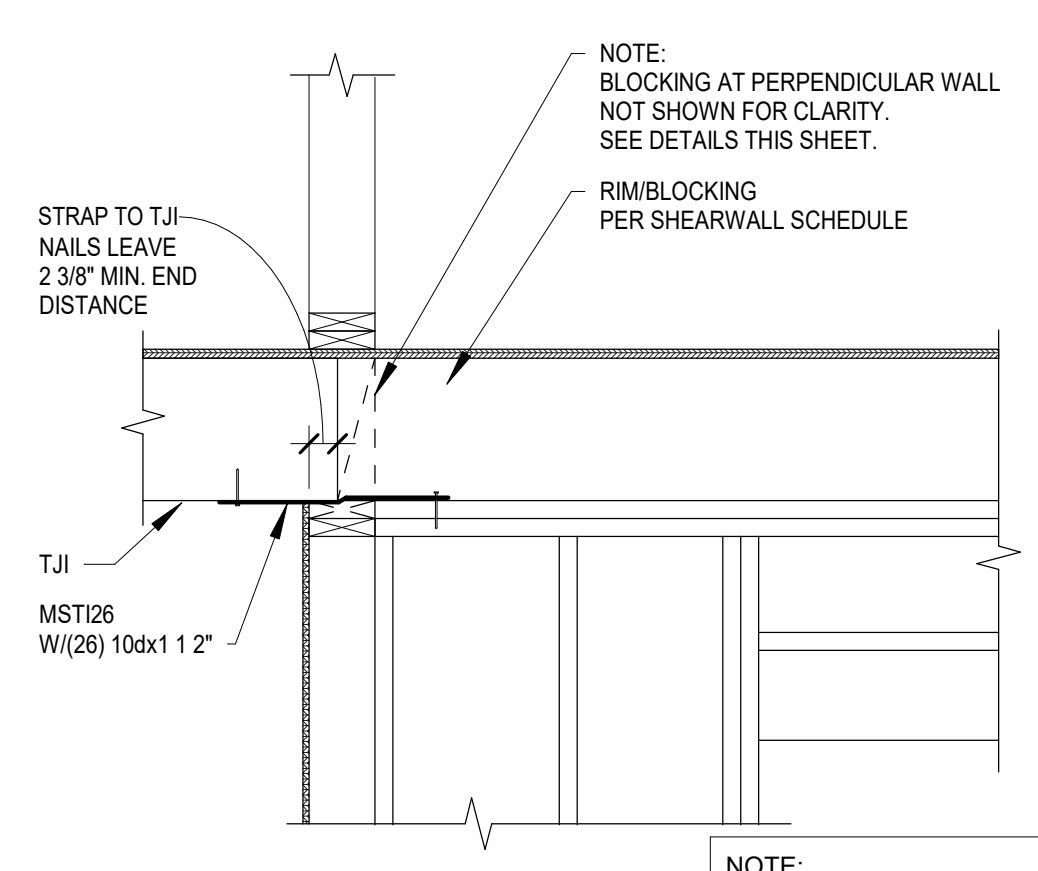

SCALE: 3/4" = 1'-0"
17 TYPICAL SHEARWALL STRAP

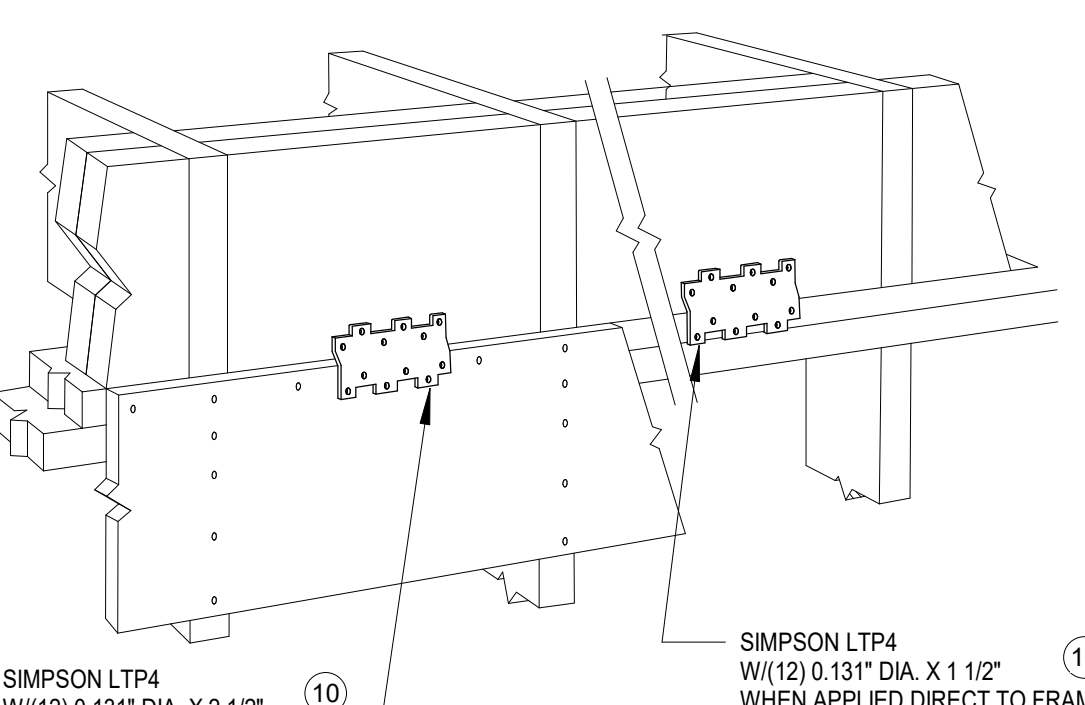

SCALE: 3/4" = 1'-0"
18 TYPICAL SIMPSON LTP4 AT INTERIOR SHEARWALL

SHEARWALL SCHEDULE - 7/16\"/>

WALL TYPE	SHEATHING (2)	PANEL EDGE NAILING (3)	FIELD NAILING (4)	BOTTOM PLATE NAILING (7)		RIM OR BLOCKING TO TOP PLATE CONN. (10)			FRAMING AT ADJOINING PANEL EDGES (5)	FOUNDATION SILL PLATE (12)	ANCHOR BOLT SPACING 5/8\"/>
				ROWS	SPACING	0.148\"/>					

REFERS TO KEYNOTES IN DETAIL 19 THIS SHEET

- SHEARWALL SCHEDULE NOTES:
- STUDS SHALL NOT BE SPACED MORE THAN 16\"/>
 - RE: S1.0 SECTION 06100 \"ROUGH FRAMING\" FOR REQUIRED WALL STUD AND PLATE SPECIES AND GRADE.
 - RE: S1.0 SECTION 06160 \"WOOD SHEATHING\" FOR REQUIRED SHEAR WALL SHEATHING, THICKNESS AND GRADE. ALL SHEAR WALL PANELS SHALL BE APPLIED DIRECTLY TO FRAMING.
 - SHEATHING PANELS MAY BE INSTALLED EITHER HORIZONTALLY OR VERTICALLY WITH ALL PANEL EDGES BACKED/BLOCKED WITH 2\"/>
 - FRAMING MEMBERS RECEIVING EDGE NAILING FROM ADJUTING PANELS SHALL NOT BE LESS THAN 3\"/>
 - WHERE PANELS ARE APPLIED ON BOTH FACES OF A WALL AND NAIL SPACING IS LESS THAN 6\"/>
 - STUDS AND PLATE: HEM-FIR #2 OR BETTER
 - FLOOR THICKNESS: 2 3/8\"/>
 - ROOF THICKNESS: X
 - ANCHOR BOLT: 5/8\"/>
 - RIM/BLOCKING: 0.148\"/>
 - VERTICAL LOAD TRANSFER CAPACITY 3300 LB./FT.
 - LATERAL LOAD TRANSFER CAPACITY (1.25\"/>
 - LATERAL LOAD TRANSFER CAPACITY (3.50\"/>
 - ALL WOOD IN CONTACT WITH CONCRETE OR MASONRY SHALL BE PRESERVATIVE TREATED.
 - WHERE BOTTOM PLATE NAILING SPECIES OF 4 INCHES OR LESS NAILS SHALL BE INSTALLED IN TWO ROWS OFFSET 1/2 INCH AND STAGGERED.
 - GALVANIZED EXPANSION ANCHORS OF SIMILAR DIAMETER AND EMBEDMENT ALLOWED AT INTERIOR BEARING AND PARTY WALLS.
 - 2-2X'S IN LIEU OF 3X'S AT PANEL EDGES ACCEPTABLE PROVIDED STUDS ARE ATTACHED PER 10/S1.2 SIM. AND BOTTOM PLATE NAILING.
 - WHERE BUILDING OFFICIALS ALLOW, OSB SHEATHING MAY BE APPLIED OVER 1/2\"/>

SCALE: NONE

SHEARWALL SCHEDULE

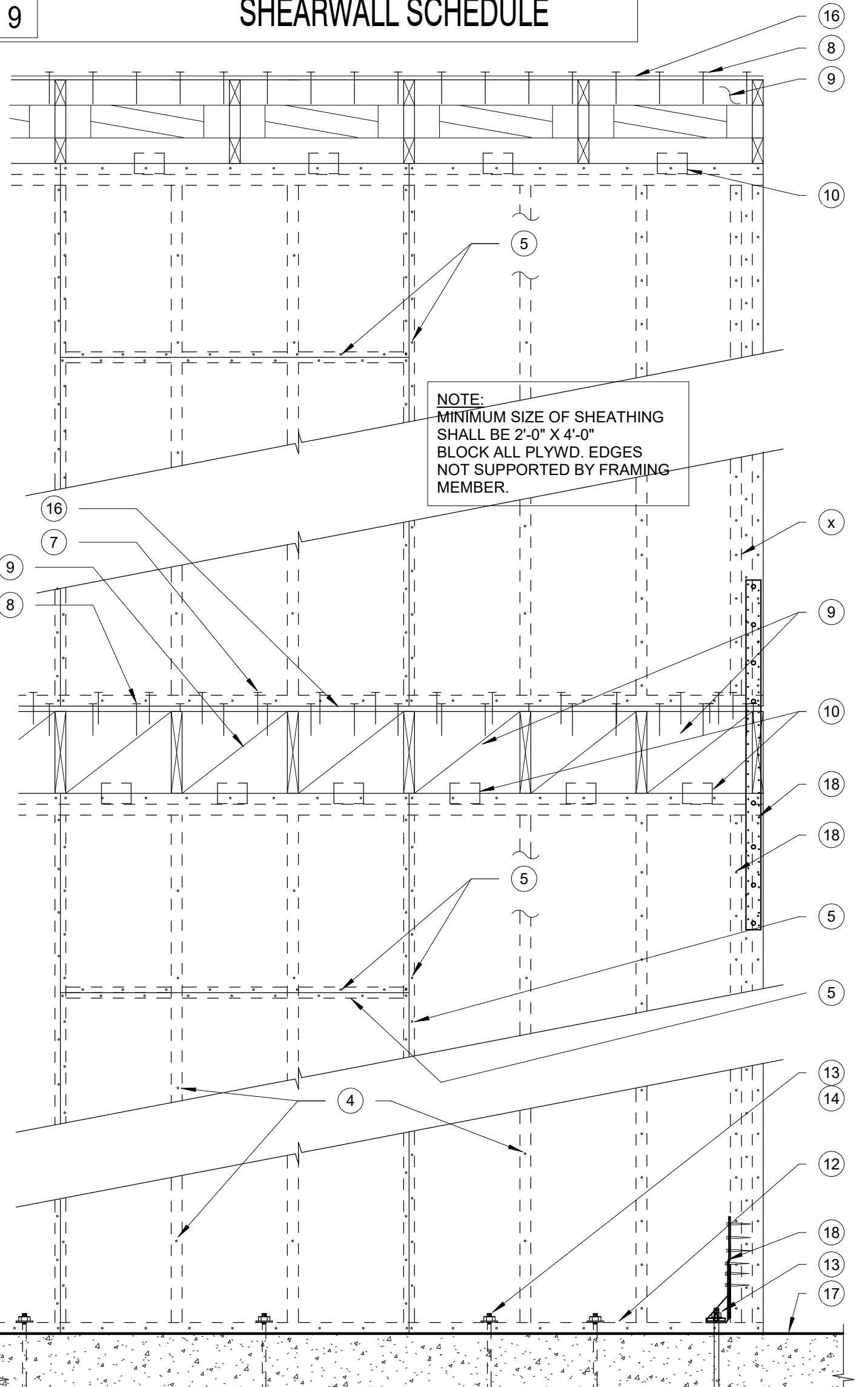

SCALE: 3/4" = 1'-0"
9 TYPICAL SHEARWALL NOMENCLATURE (ELEVATION)

- (1) SHEARWALL TYPE W1 SHEATHING: 7/16\"/>
- (2) WALL SHEATHING: SHEATHING PANELS MAY BE INSTALLED EITHER VERTICALLY OR HORIZONTALLY. ALL PANEL EDGES SHALL BE FASTENED TO STUDS OR BLOCKING.
- (3) PANEL EDGE NAILING: NAILING AT ALL OUTER EDGES OF SHEATHING PANELS IN SHEARWALLS SHALL BE FASTENED PER THE SHEARWALL SCHEDULE.
- (4) FIELD NAILING: WITHIN THE FIELD OF THE PANEL, AT FRAMING MEMBERS, THE PANELS ARE LESS CLOSELY FASTENED.
- (5) FRAMING AT ADJOINING PANEL EDGES: WHERE TWO PIECES OF PLYWOOD JOIN ON A FRAMING MEMBER, THE PANEL EDGE NAILING FROM EACH PANEL IS TO BE STAGGERED. SOME WALLS REQUIRE 3 INCH NOMINAL FRAMING MEMBER (EITHER A STUD OR BLOCKING) AT ADJOINING PANEL EDGES (SEE SHEARWALL SCHEDULE FOR WALL TYPES REQUIRING 3 INCH NOMINAL FRAMING MEMBERS AT ADJOINING PANEL EDGES). DOUBLED STUDS ARE GENERALLY NOT ACCEPTABLE FOR THIS APPLICATION. WHERE A SINGLE PANEL EDGE LANDS ON A FRAMING MEMBER, A 2 INCH NOMINAL FRAMING MEMBER SHALL BE ACCEPTABLE (AT ENDS OF WALLS FOR EXAMPLE). BLOCK ALL PLYWOOD EDGES NOT SUPPORTED BY FRAMING MEMBERS AND NAIL W/PANEL EDGE NAILING.
- (6) BOTTOM PLATE:
- (7) BOTTOM PLATE NAILING: LOCATE THE NAILING THROUGH THE BOTTOM PLATE SO AS TO FULLY PENETRATE THE SOLID BLOCKING OR CONTINUOUS RIM BENEATH THE FLOOR SHEATHING, SPACED AS PER THE SHEARWALL SCHEDULE.
- (8) ROOF DIAPHRAGM BOUNDARY EDGE NAILING: FLOOR DIAPHRAGM NAILING SHALL BE INSTALLED BETWEEN THE SPACING SHOWN FOR BOTTOM PLATE NAILING. LOCATE ADJOINING PANEL EDGES OF FLOOR SHEATHING AWAY FROM SHEARWALLS. FIELD NAILING OF FLOOR SHEATHING MAY BE OMITTED AT SHEARWALL BOTTOM PLATE NAILING. RE: NOTES 06500
- (9) TRUSS BLOCKING PANEL: JOIN ADJACENT TRUSS BLOCKING PANEL WITH FACE NAILING AS SPECIFIED ABOVE. SHIM WITH FULL HEIGHT SHIMS. ADJUST FACE NAIL LENGTHS. REFER TO PLANS FOR ADDITIONAL SEISMIC CONNECTIONS AT THE FLOOR OR ROOF LEVEL.
- (10) TRUSS BLOCKING PANEL TO TOP PLATE CONNECTION: THE CONTINUOUS TRUSS BLOCKING PANEL THAT IS PART OF THE SHEARWALL ASSEMBLY SHALL BE CONNECTED TO THE DOUBLE TOP PLATE OR FOUNDATION SILL PLATE WITH APPROVED CONNECTORS AND SPACED PER THE SHEARWALL SCHEDULE.
- (11) DOUBLE TOP PLATE: LAP AND SPACING SHALL BE AS PER PLANS FOR ADDITIONAL SEISMIC CONNECTIONS AT THE FLOOR OR ROOF LEVEL.
- (12) FOUNDATION SILL PLATE: ALL WOOD IN CONTACT WITH CONCRETE OR MASONRY SHALL BE PRESERVATIVE TREATED. THE FOUNDATION SILL PLATE SHALL BE EITHER 2 INCH NOMINAL OR 3 INCH NOMINAL DEPENDING ON THE SHEARWALL SCHEDULE.
- (13) ANCHOR BOLTS: FULL DIAMETER ANCHOR BOLTS, ASTM A-307 SHALL BE SECURED IN PLACE PRIOR TO PLACING CONCRETE. MINIMUM EMBEDMENT IS 7 INCHES. MIN. (2) BOLTS PER PIECE OF PLATE, W/1\"/>
- (14) PLATE WASHERS: PLATE WASHERS SHALL BE REQUIRED FOR FOUNDATION SILL PLATE CONNECTIONS. 3\"/>
- (15) SQUASH BLOCKS: IN THE FLOOR CAVITY OF PLATFORM FRAMING POST LOADS SHALL BE PROVIDED WITH ADDITIONAL STIFFENERS EQUAL TO THE POST SIZE FROM ABOVE THAT CONTINUES THROUGH THE FLOOR.
- (16) DIAPHRAGM: SEE (1) FOR SHEARWALL, FLOOR AND ROOF DIAPHRAGM THICKNESS.
- (17) CONCRETE BASE: CONCRETE FOUNDATION OR BASE.
- (18) HOLDDOWN: SEE SHEET S1.2 FOR HOLDOWN DETAILS AND ADDITIONAL STUDS REQUIRED.

CT ENGINEERING INC.
Structural Engineers
180 Neckerson Street, Suite 302, Seattle, WA 98109
206.265.4512 (V) 206.265.0616 (F)
www.ctengineering.com

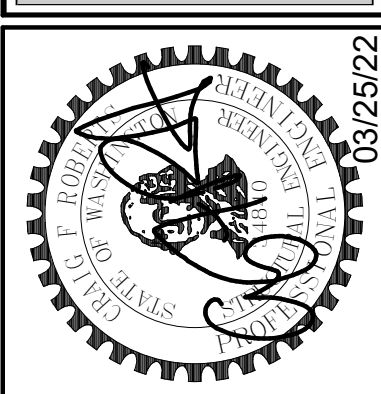

NO.	REVISION	DATE

JOB #: 21162
 ENG: BJM
 CAD: JMA
 SCALE: 3/4" = 1'-0"
 KEY ISSUE DATES:
 SD: SD
 CD: CD
 PERMIT: 03/26/2022
 OTHER: BD

Shearwall Schedule and Details
PIPER REMODEL
8429 SE 33RD PLACE
MERCER ISLAND, WA 98040

S1.1

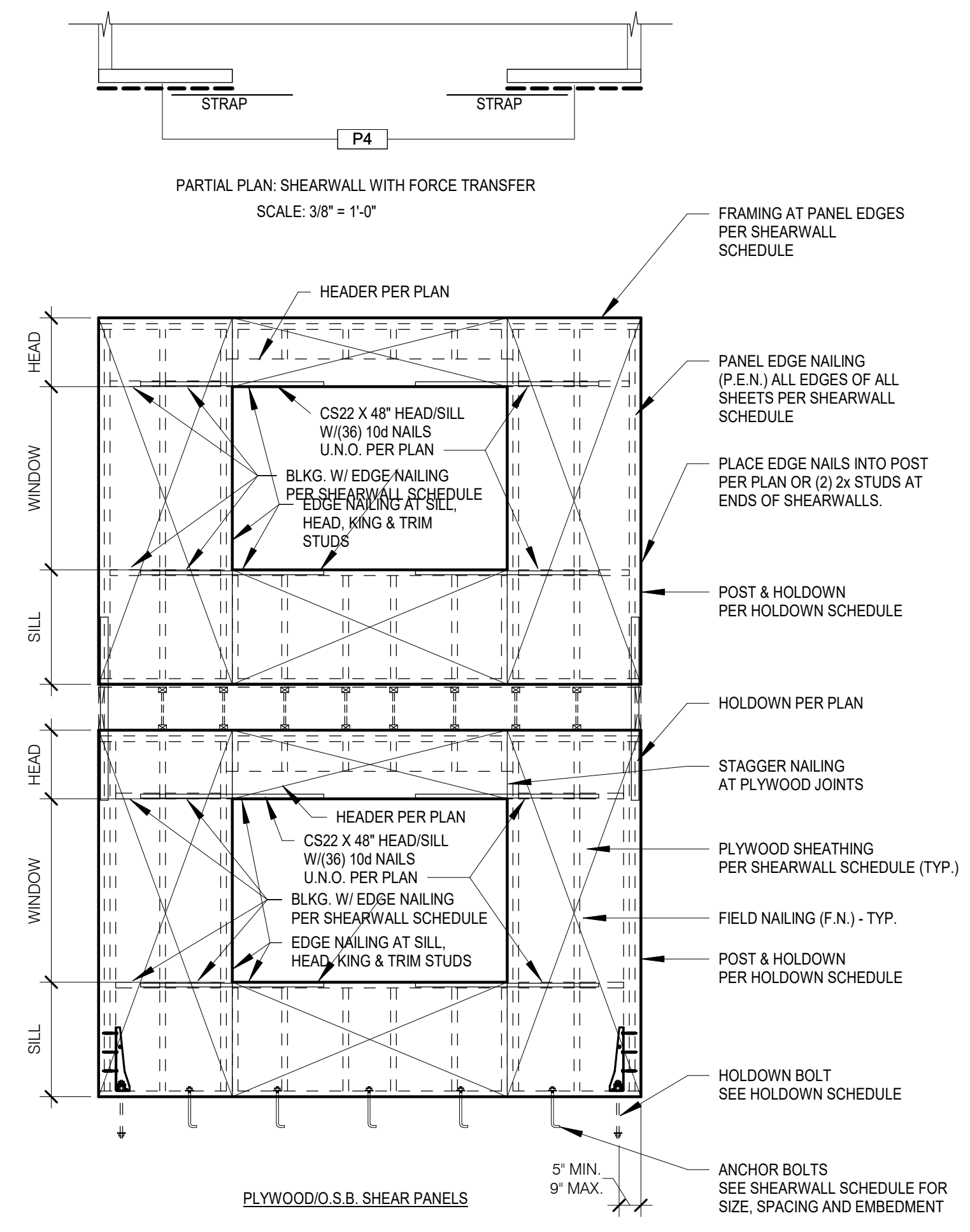

LOAD	MARK	HARDWARE TYPE	WOOD MEMBER/POST		FASTENER	ROD DIAMETER	ANCHOR			STEM (MINIMUM)	DETAIL
			2X4 WALL	2X6 WALL			STEM	THICKENED FOOTING	GRADE BEAM		
1705	HD1	CS16	2X4	2X6	(28) 8d	N.A.	N.A.	-	N.A.	-	N.A.
2345	HD2	MST37	(2) 2X4	(2) 2X6	(22) 16d	N.A.	N.A.	-	N.A.	-	N.A.
3640	HD3	MST48	(2) 2X4	(2) 2X6	(34) 16d	N.A.	N.A.	-	N.A.	-	N.A.
4830	HD4	MST60	(2) 2X4	(2) 2X6	(48) 16d	N.A.	N.A.	-	N.A.	-	N.A.
2.9W/2.2EQ	HD5	LSDTHD8 LSDTHD8RJ	(2) 2X4	(2) 2X6	(16) 12d	STRAP	N.A.	-	8"	-	8"
5.3W/3.8EQ	HD6	STDH14 STDH14RJ	(2) 2X4	(2) 2X6	(24) 12d	STRAP	N.A.	-	14"	-	8"
3580	HD7	HTT22	(2) 2X4	(2) 2X6	(32) 12d	5/8"	N.A.	-	9"	-	8"
2215	HD8	HDU2-SDS2.5	(2) 2X4	(2) 2X6	(6) SDS 1/4X2 1/2"	5/8"	ROD & NUT/WASHER NUT PER 13/S1.2	-	11"	-	6"
3285	HD9	HDU4-SDS2.5	(2) 2X4	(2) 2X6	(10) SDS 1/4X2 1/2"	5/8"		-	11"	-	6"
4065	HD10	HDU5-SDS2.5	(2) 2X4	(2) 2X6	(14) SDS 1/4X2 1/2"	5/8"		-	11"	RE: 13/S1.2	6"
4305/6970	HD11	HDU8-SDS2.5	(2) 2X4	(2) 2X6	(20) SDS 1/4X2 1/2"	7/8"		-	11"	-	8"
9535	HD12	HDU11-SDS2.5	4X6	6X6	(30) SDS 1/4X2 1/2"	1"		-	16"	-	8"
1492	HD13	HD19	-	6X6	(5) 1"DIA. M.B.	1 1/4"	-	16"	-	8"	
	HD14	HDU14-SDS2.5	4X6	6X6	(36) SDS 1/4X2 1/2"	1"	-	16"	-	8"	
	HD15	MSTC48B3	(2) 2X4	(2) 2X6	(12) 10d FACE, (4) 10d BOTTOM, (38) 10d STUDS/POST						

- HOLDOWN AND FASTENER SCHEDULE NOTES:**
- HOLDOWNS SHALL BE AS MANUFACTURED BY THE SIMPSON STRONG-TIE COMPANY.
 - 16D = 0.162" DIA. X 3 1/2" LONG.
 - USE HALF THE REQUIRED NAILS IN EACH MEMBER BEING CONNECTED.
 - SCREWS SHALL BE SDS 1/4" DIA. X 2 1/2" AS MANUFACTURED BY SIMPSON STRONG-TIE COMPANY.
 - HOLDDOWN ANCHORS SHALL BE SECURED IN PLACE PRIOR TO PLACING CONCRETE.
 - ANCHOR BOLT NUT SHALL BE FINGER-TIGHT PLUS 1/3 - 1/2" TURN WITH HAND WRENCH. CARE SHALL BE TAKEN TO NOT OVER-TORQUE THE NUT. IMPACT WRENCHES SHALL NOT BE USED.
 - HDU HOLDOWNS SHALL BE INSTALLED CENTERED ALONG THE WIDTH OF THE ATTACHED POST.
 - RE: NOTES SECTION 06100 "ROUGH FRAMING" FOR THE REQUIRED POST SPECIES AND GRADE.
 - BUNDLED STUDS PER DETAIL 10/S1.2
 - STRAP TIE HOLDOWNS. NAIL STRAPS FROM BOTTOM UP. INSTALL WITH STRAP MATE "NO WET STICKING".
 - ANCHOR BOLT HOLDOWNS SHALL BE ASTM A307 OR A36 STEEL. ANCHOR HEAD REQUIRES NUT/WASHER NUT PER 2/S1.2.

TYPICAL DETAIL FOR SHEARWALL W/ FORCE TRANSFER AROUND WINDOW OPENINGS
SCALE: 3/4" = 1'-0"

10 SHEARWALL SCHEDULE
SCALE: 3/4" = 1'-0"

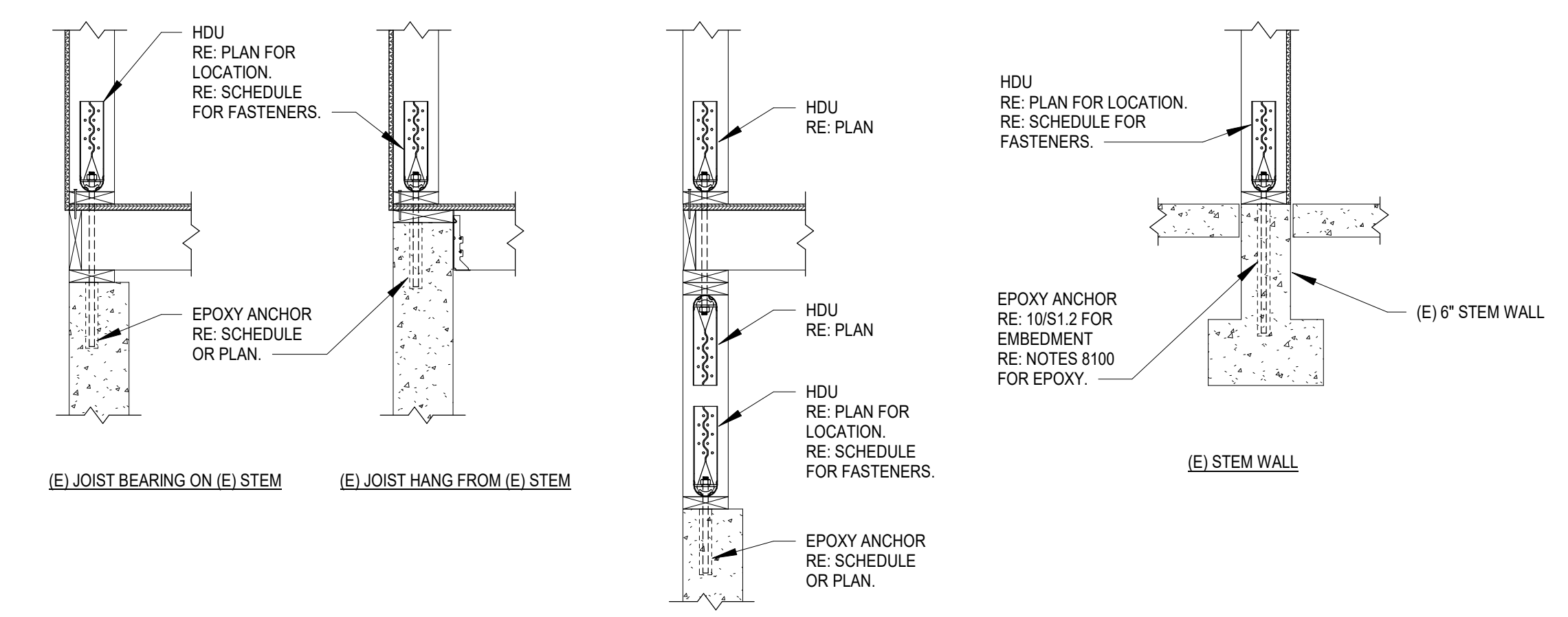

11 EPOXY ANCHORAGE OF HDU TYPE HARDWARE
SCALE: 3/4" = 1'-0"

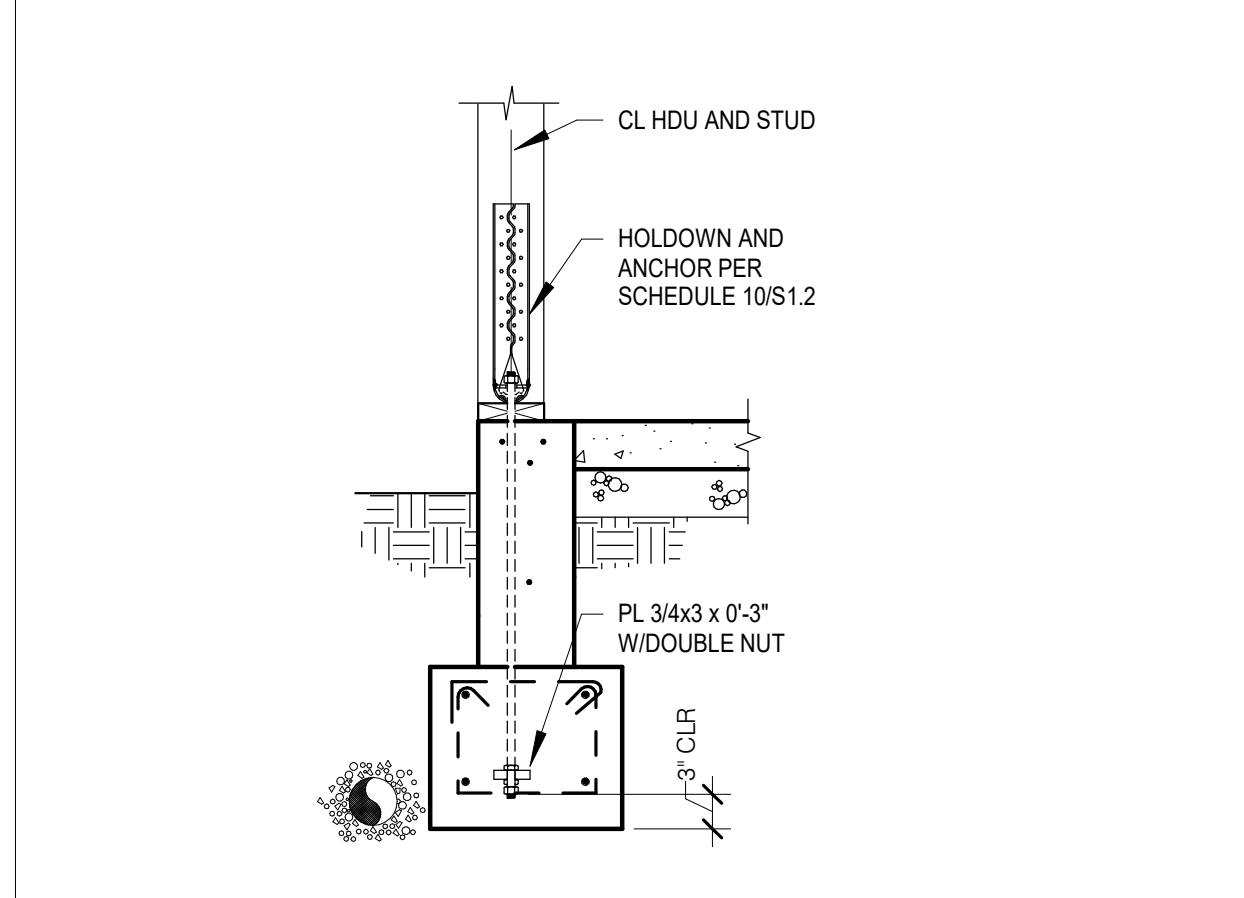

13 EXTERIOR HOLDOWN - SECTION
SCALE: 3/4" = 1'-0"

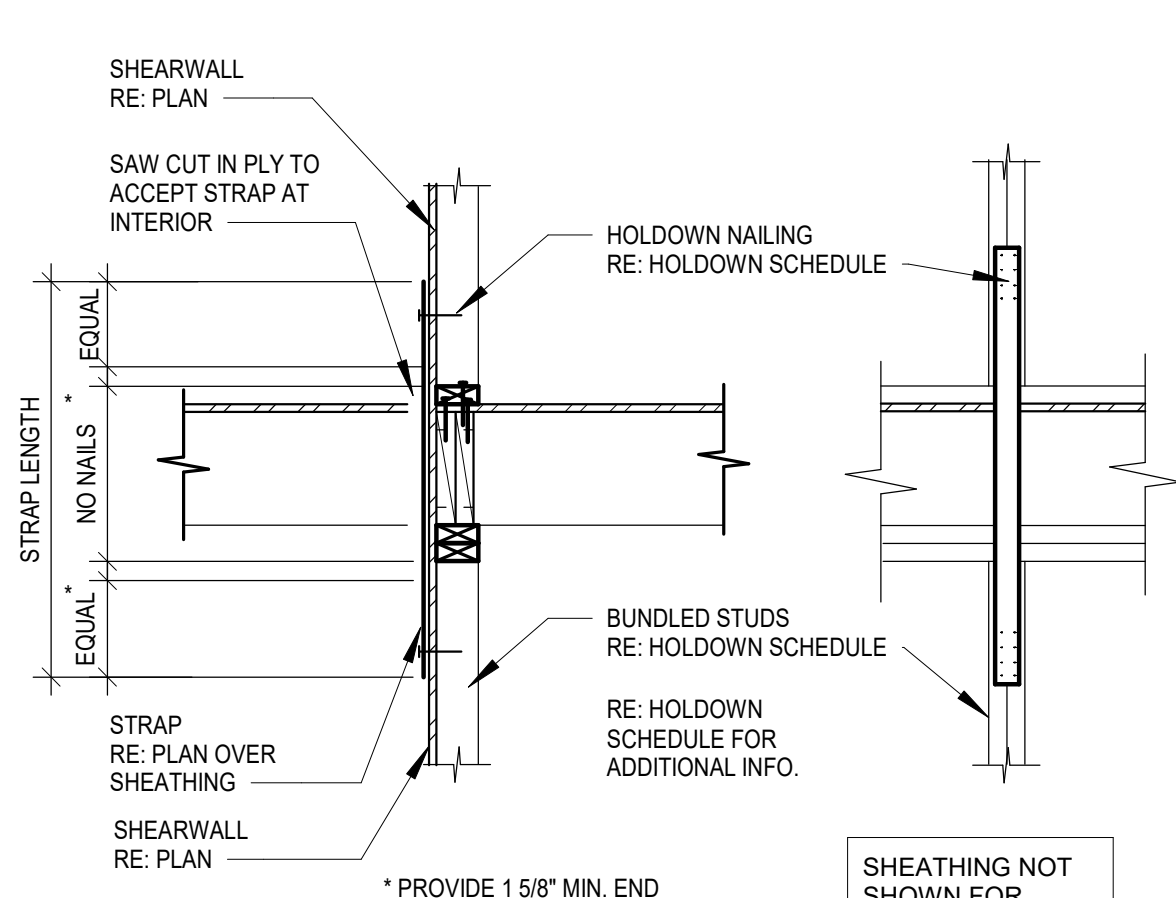

14 INTERIOR HOLDOWN
SCALE: 3/4" = 1'-0"

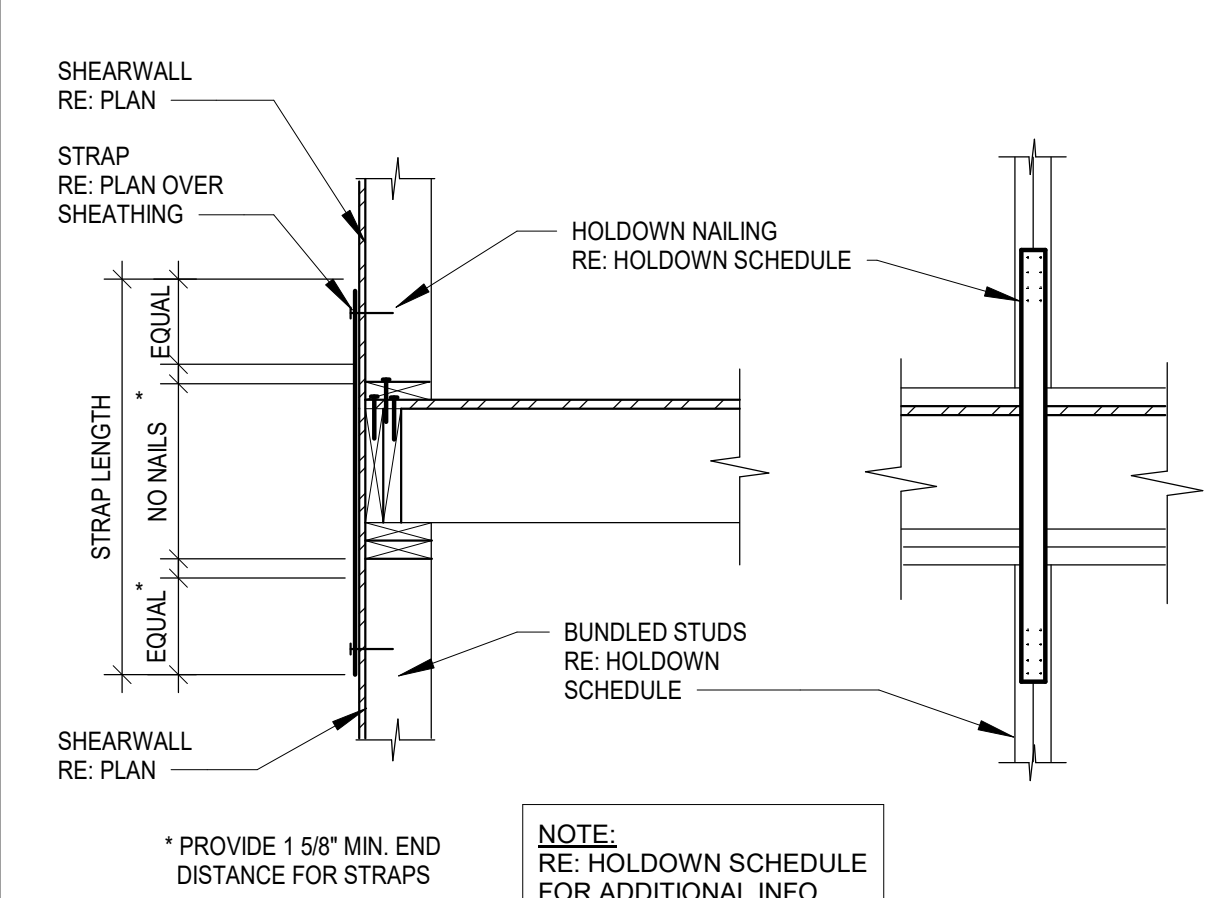

15 EXTERIOR HOLDOWN
SCALE: 3/4" = 1'-0"

CT ENGINEERING INC.
Structural Engineers
180 Nickerson Street, Suite 302, Seattle, WA 98109
206.265.4512 (V) 206.265.0616 (F)
www.ctengineering.com

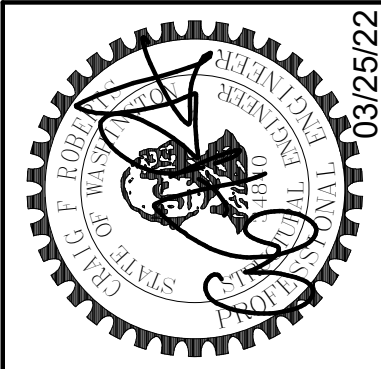

NO.	REVISION	DATE

JOB #: 21162
ENG: BJM
CAD: JMA
SCALE: 3/4" = 1'-0"
KEY ISSUE DATES:
SD: SD
CD: CD
PERMIT: 03.25.2022
OTHER: BD

Holddown Schedule and Details
PIPER REMODEL
8429 SE 33RD PLACE
MERCER ISLAND, WA 98040

S1.2

FOUNDATION LEGEND

- (F1) SEE FOOTING TYPE THIS SHEET
 - (-3'-0") TOP OF FOOTING ELEVATION
 - 2'-0" TOP OF CONCRETE ELEVATION
 - S.J. SHRINKAGE CONTROL JOINT PER DETAIL 2/S6.0
 - C.J. CONSTRUCTION JOINT PER DETAIL 3/S6.0
 - (S) STEPPED FOOTING PER DETAIL 485/S6.0
 - SLOPE SLOPE SLAB 1/4" PER FOOT U.N.O. PER PLAN
 - HD/2 HOLD-DOWNS INDICATED ON THE FOUNDATION PLAN ARE SHOWN HALFTONE FOR REFERENCE ONLY. REFER TO THE S2.1 SHEET FOR SPECIFICS OF EMBEDDED ITEMS RELATED TO HOLD-DOWNS.
- Note:**
ALL SECTION CUTS ARE TYPICAL
- DARK SOLID LINES ARE NEW WALLS ABOVE THE BASEMENT LEVEL.
 - LIGHT SOLID LINES ARE EXISTING WALLS ABOVE THE BASEMENT LEVEL.

FOUNDATION SCHEDULE

MARK	DEPTH	WIDTH	LENGTH	REINFORCING	DETAILS
(F1)	8"	1'-4"	CONT.	(2) #4 CONT.	FTG. W/ STEM WALL: 687/S6.0
(FS)	12"	1'-6"	CONT.	(2) #4 CONT.	TYP. THICKENED SLAB FOOTING
(F24)	12"	24"	24"	(2) #4 EA. WAY	POST FTG.: 9/S6.0 16&17/S6.0
(F30)	12"	30"	30"	(3) #4 EA. WAY	POST FTG.: 9/S6.0 16&17/S6.0
(F36)	12"	36"	36"	(3) #4 EA. WAY	POST FTG.: 9/S6.0 16&17/S6.0
(F1)	8"	1'-4"	CONT.	(2) #4 CONT.	TURNED DOWN SLAB EDGE 6,7,8/S6.0

FOUNDATION NOTES

1. ALL SOIL BEARING SURFACES ARE SUBJECT TO INSPECTION AND APPROVAL BY THE GEOTECHNICAL ENGINEER PRIOR TO REINFORCING AND CONCRETE PLACEMENT.
2. CENTER INTERIOR FOOTINGS ON WALLS OR COLUMNS TYPICAL U.N.O.
3. VERIFY ALL DIMENSIONS PRIOR TO CONSTRUCTION.
4. SEE ARCHITECTURAL PLANS FOR WALL LOCATIONS.
5. CONCRETE WALLS ARE 8" THICK TYPICAL U.N.O.
6. SEE SHEET S2.1 FOR WOOD FRAMING LEGEND, NOTES, AND SCHEDULES.
7. PROVIDE 4" DIAMETER PERFORATED FOOTING DRAINS AT PERIMETER OF FOUNDATIONS TYPICAL. PROVIDE 4" DIAMETER TIGHTLINES FOR DOWNSPOUTS, EXTEND TO DAYLIGHT.

FOUNDATION KEY NOTES

- 20.1
- 20.2

NOTE:
PLANS PREPARED USING ARCHITECTURAL BACKGROUNDS RECEIVED 02/28/2022.

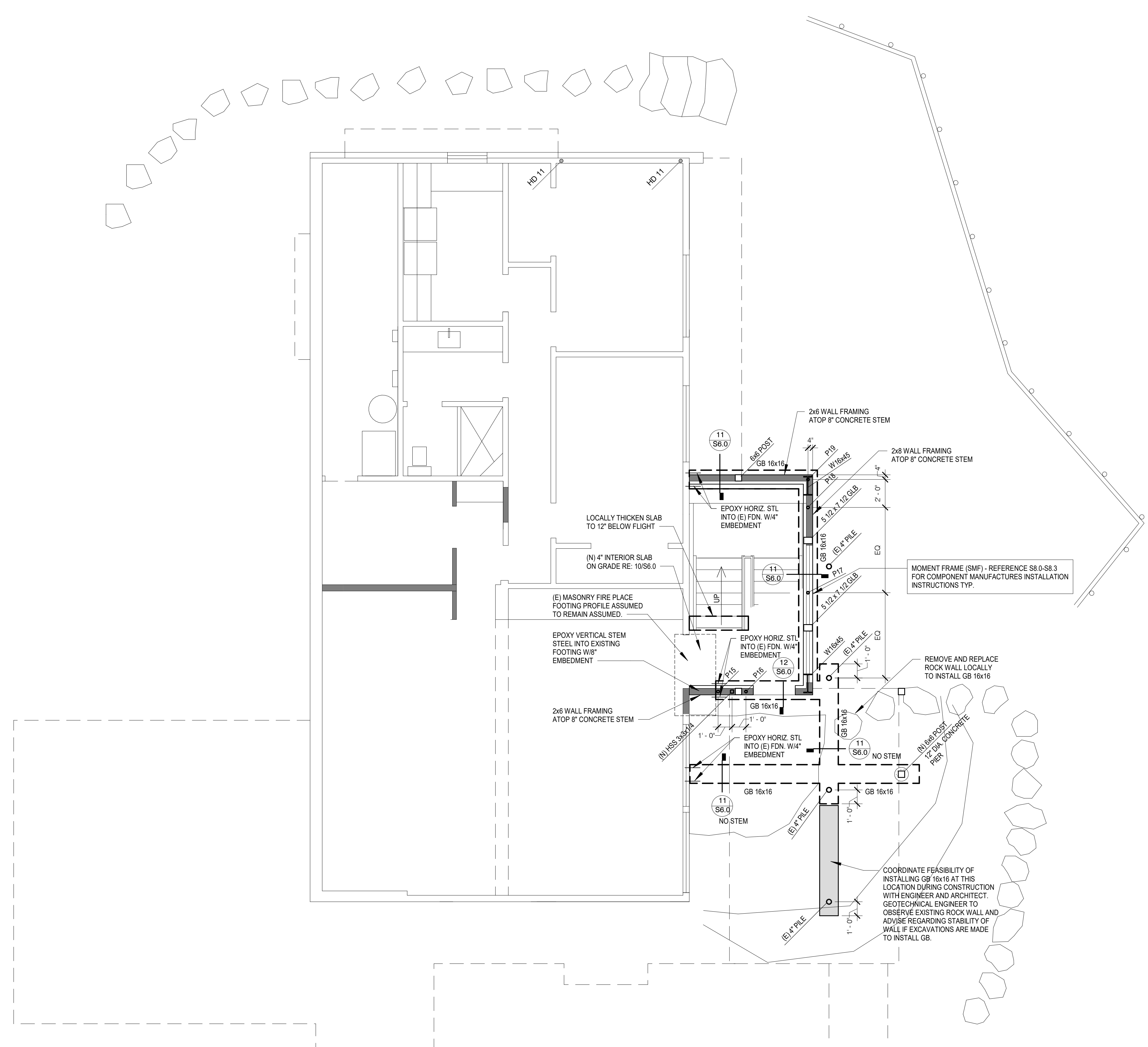

SCALE: 1/4" = 1'-0"
0

Foundation Plan

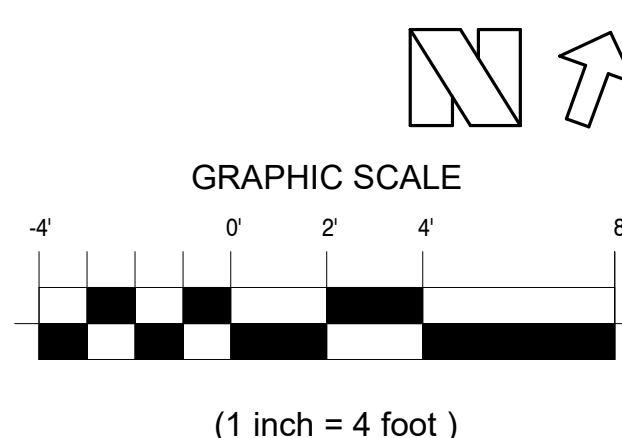

Basement Level Walls Over Foundation

PIPER REMODEL
8429 SE 33RD PLACE
MERCER ISLAND, WA 98040

S2.0

CT ENGINEERING INC.
Structural Engineers
180 N. Jackson Street, Suite 302, Seattle, WA 98109
206.265.4512 (V) 206.265.0616 (F)
www.ctengineering.com

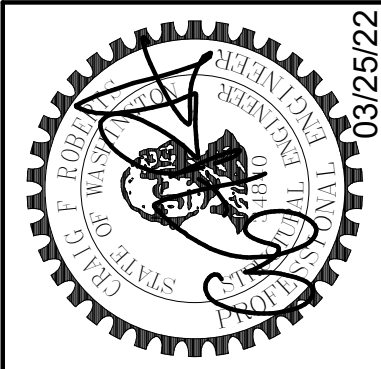

No.	REVISION	DATE

JOB #: 21162
ENG: BJM
CAD: JMA
SCALE: As indicated
KEY ISSUE DATES:
SD: SD
CD: CD
PERMIT: 03/25/2022
OTHER: BD

BAR SIZE	f _c =3000 PSI	
	OTHER BARS LAP SPLICE	TOP BARS LAP SPLICE
#3	16"	21"
#4	22"	28"
#5	27"	36"
#6	33"	43"

- LAP SPLICE SCHEDULE NOTES:
- TENSION LAP SPLICE SHOWN ABOVE FOR CONCRETE COVER GREATER THAN OR EQUAL TO BAR DIAMETER AND CENTER TO CENTER SPACING GREATER THAN OR EQUAL TO TWO BAR DIAMETERS (SPACING AND COVER CASE 1). TENSION LAP SPLICE SHOWN ABOVE ARE CLASS B SPLICES.
 - "OTHER BARS" ARE ALL VERTICAL BARS AND HORIZONTAL BARS WITH LESS THAN 12" OF CONCRETE CAST BELOW THE BAR.
 - "TOP BARS" ARE HORIZONTAL BARS WITH MORE THAN 12" OF CONCRETE CAST BELOW THE BARS.
 - COMPRESSION LAP SPLICES SHALL BE 30 BAR DIAMETERS MIN. U.N.O. ON THE DRAWINGS
 - DEVELOPMENT LENGTH (L_d) IS "OTHER BARS", CLASS A.

SCALE: NONE
1 TYPICAL LAP SPLICE SCHEDULE

BAR SIZE	D	STANDARD 180 DEGREE HOOK			STANDARD 90 DEGREE HOOK		
		D	A OR G	J	BAR SIZE	D	A OR G
#3	6db	2 1/4"	5"	3"	#3	2 1/4"	6"
#4	6db	3"	6"	4"	#4	3"	8"
#5	6db	3 3/4"	7"	5"	#5	3 3/4"	10"
#6	6db	4 1/2"	8"	6"	#6	4 1/2"	11-0"

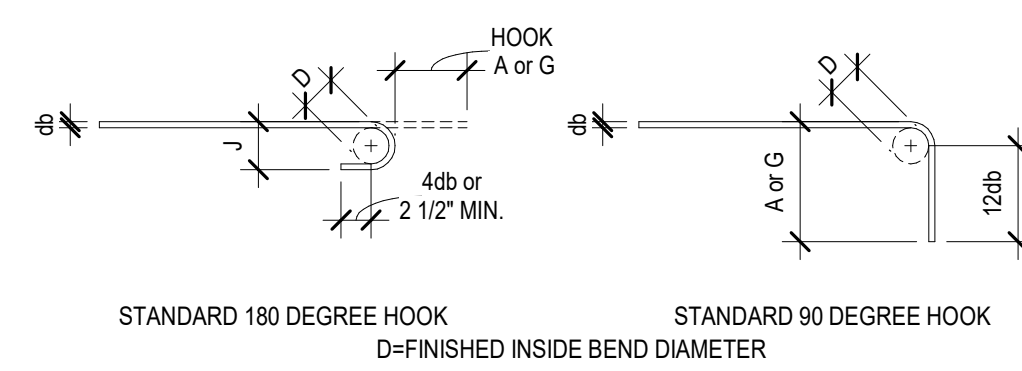

SCALE: NONE
2 STANDARD HOOK DETAILS

BAR SIZE	D	D	STIRRUP HOOKS/TIES			SEISMIC STIRRUP/TIE	
			90 DEGREE	135 DEGREE	135 DEGREE SEISMIC HOOK	A or G	APPROX. H
#3	4db	1 1/2"	4"	4"	2 1/2"	4 1/4"	3"
#4	4db	2"	4 1/2"	4 1/2"	3"	4 1/2"	3"
#5	4db	2 1/2"	6"	5 1/2"	3 3/4"	5 1/2"	3 3/4"
#6	6db	4 1/2"	1'-0"	7 3/4"	4 1/2"	7 3/4"	4 1/2"

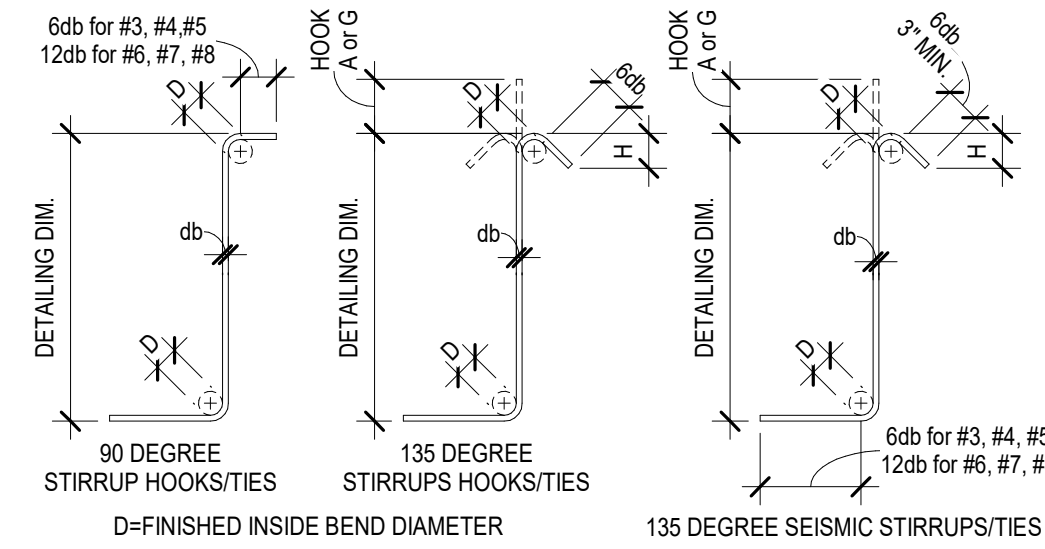

SCALE: NONE
3 STIRRUP and TIE HOOK DETAILS

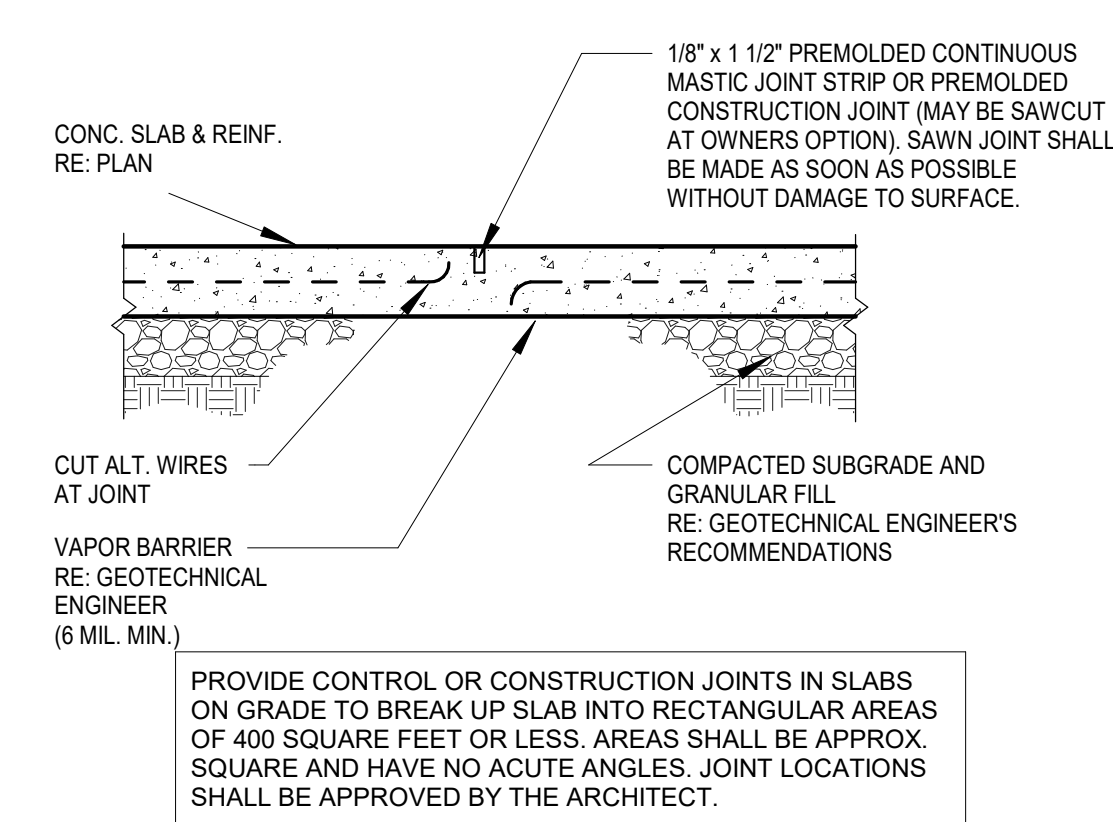

SCALE: NONE
4 TYPICAL SHRINKAGE CONTROL JOINT (S.J.)

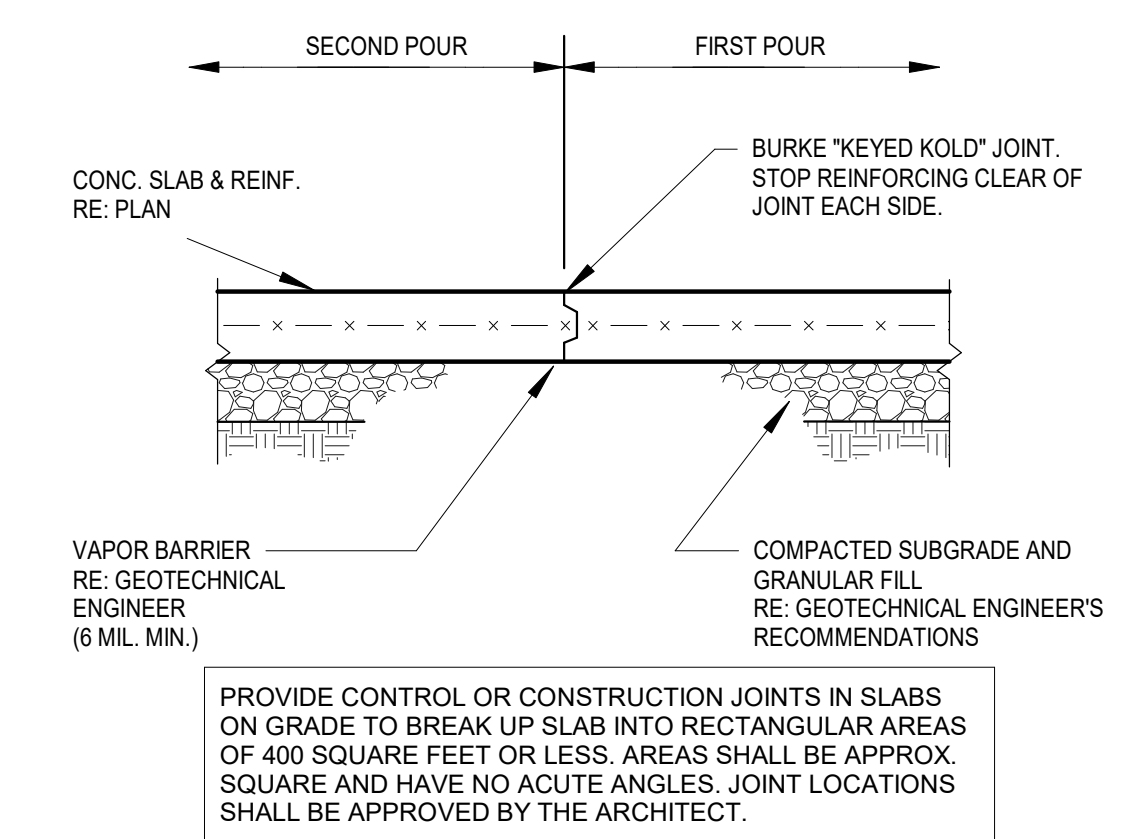

SCALE: NONE
5 TYPICAL CONSTRUCTION JOINT (C.J.)

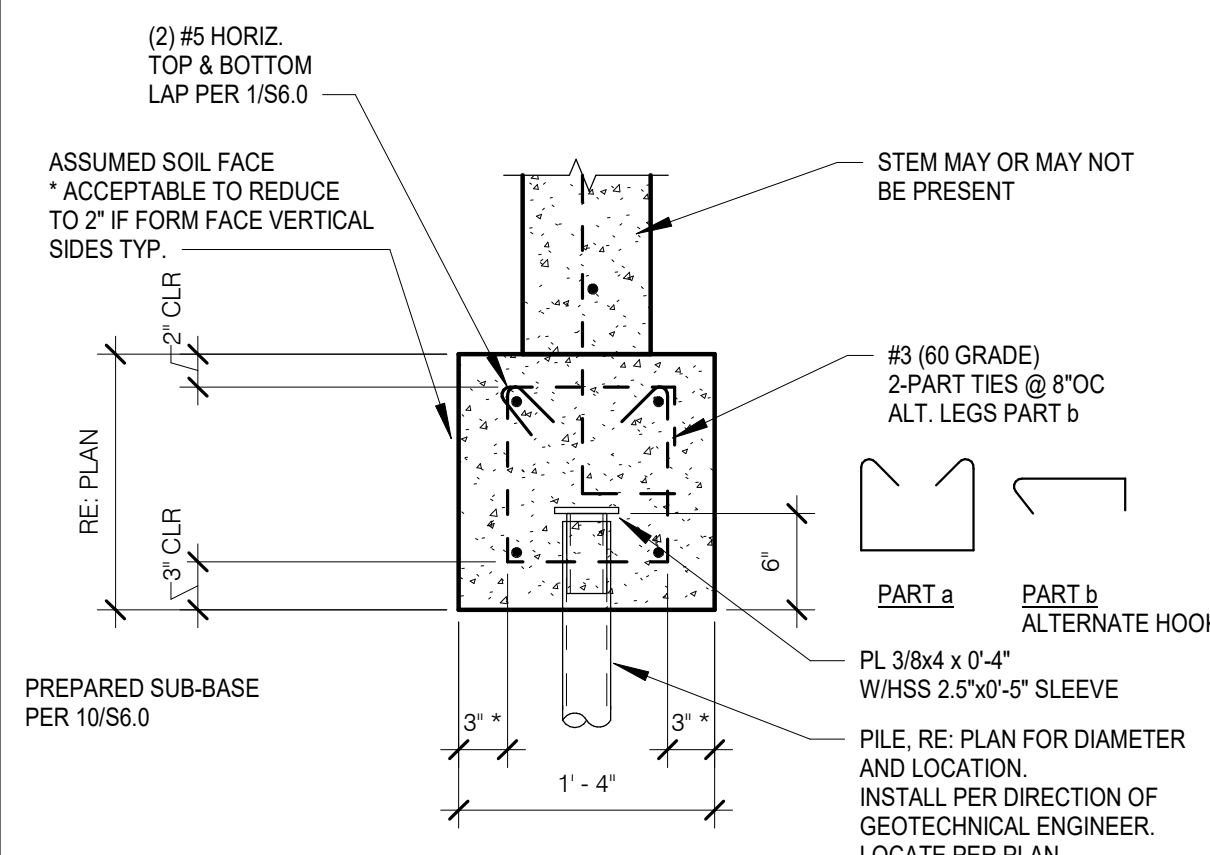

SCALE: 1" = 1'-0"
6 TYPICAL GRADEBEAM 16x16

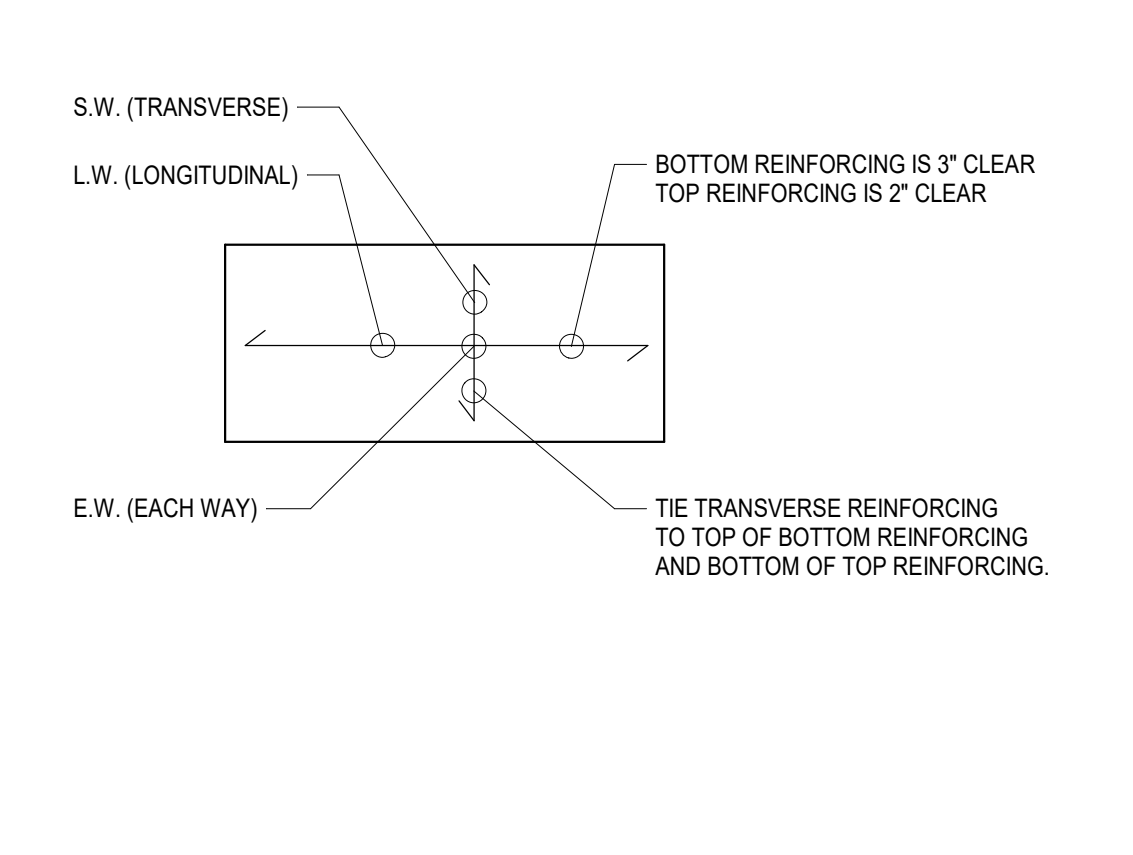

SCALE: 3/4" = 1'-0"
7 TYPICAL FOOTING REINFORCEMENT PLACEMENT

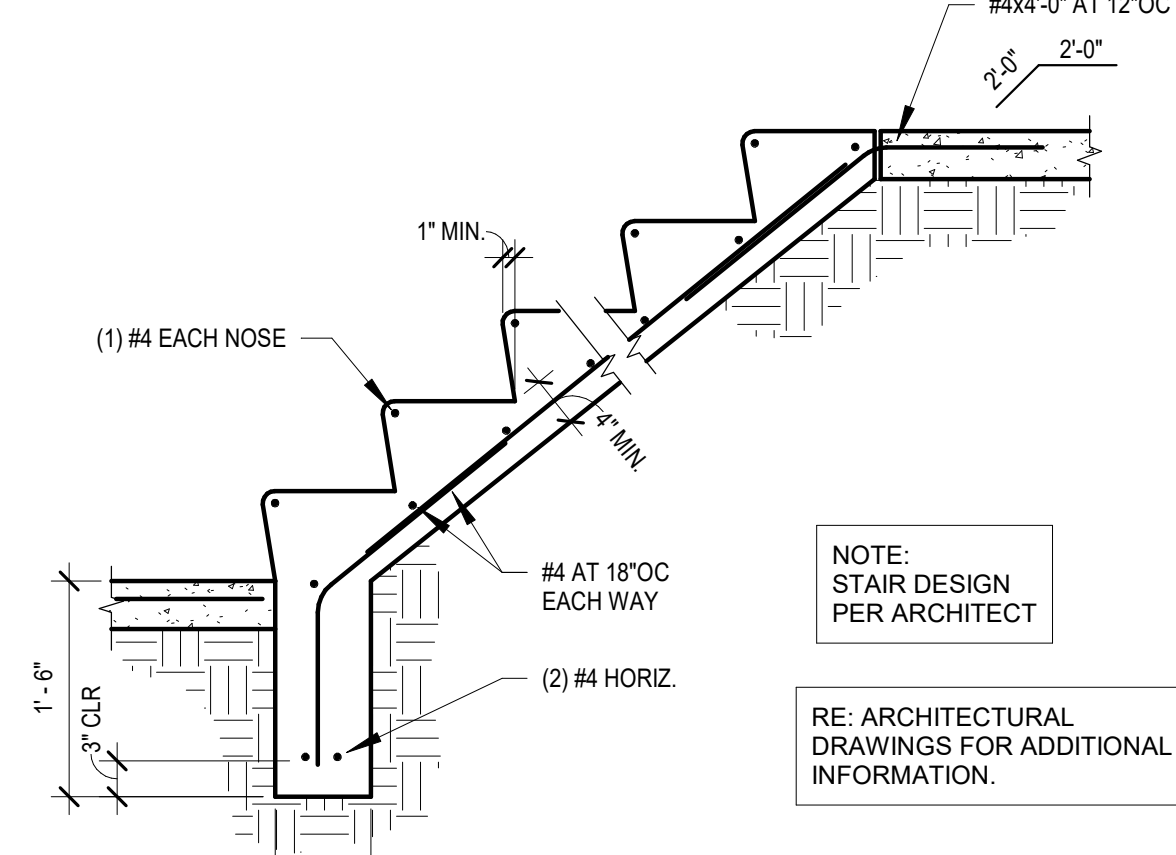

SCALE: 3/4" = 1'-0"
8 TYPICAL STAIR ON GRADE

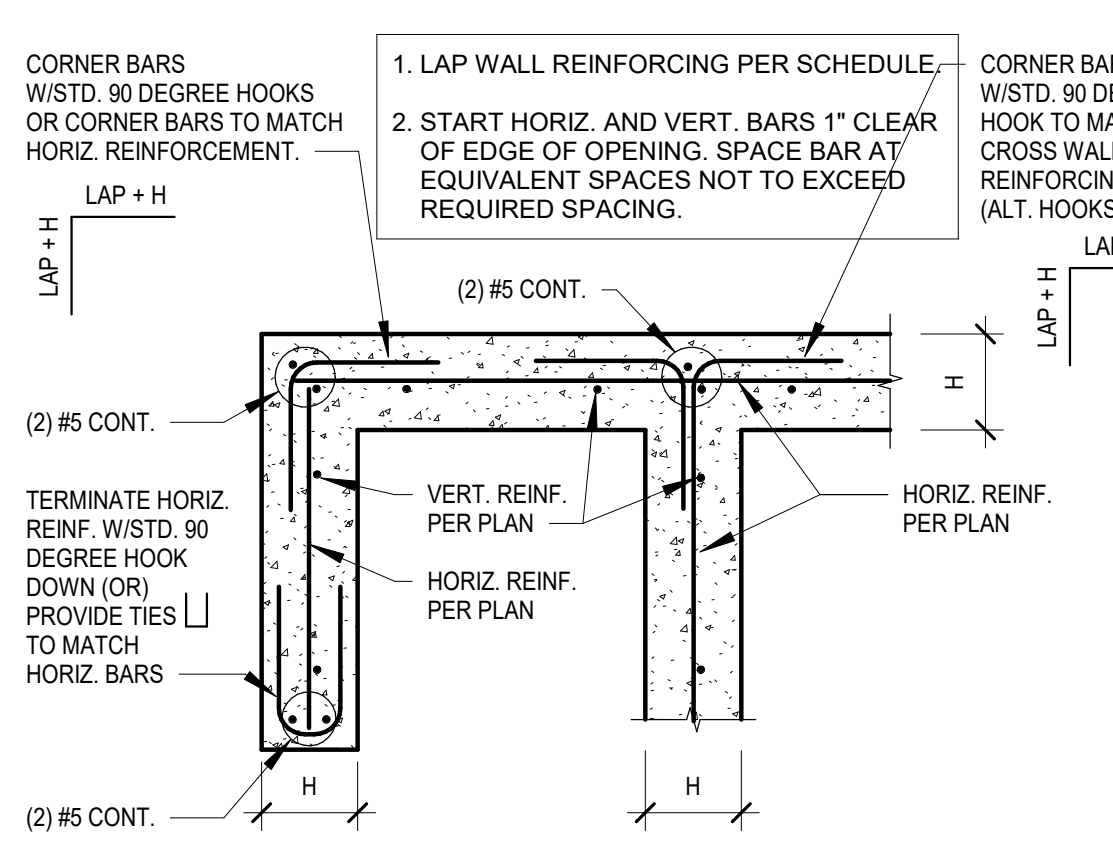

SCALE: 3/4" = 1'-0"
9 SINGLE CURTAIN WALL REINFORCEMENT PLACEMENT

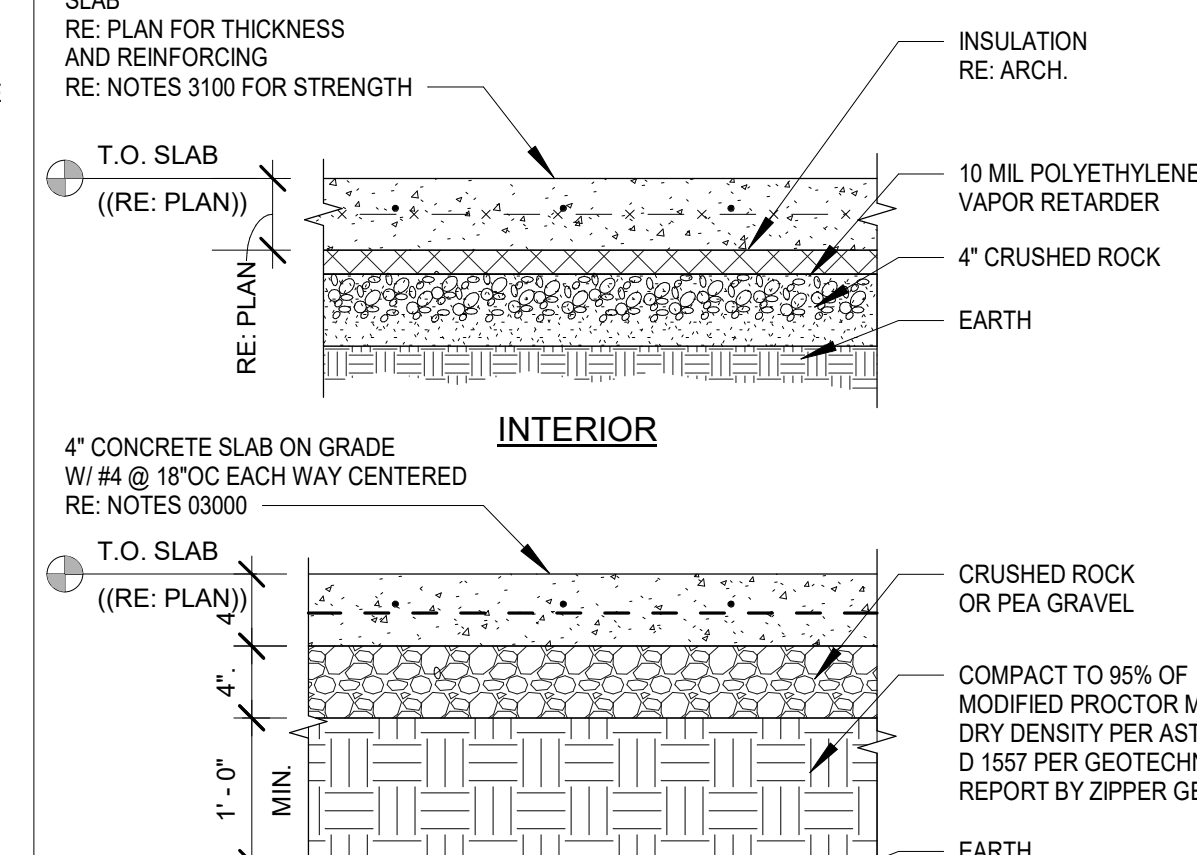

SCALE: 3/4" = 1'-0"
10 TYPICAL SLAB ON GRADE

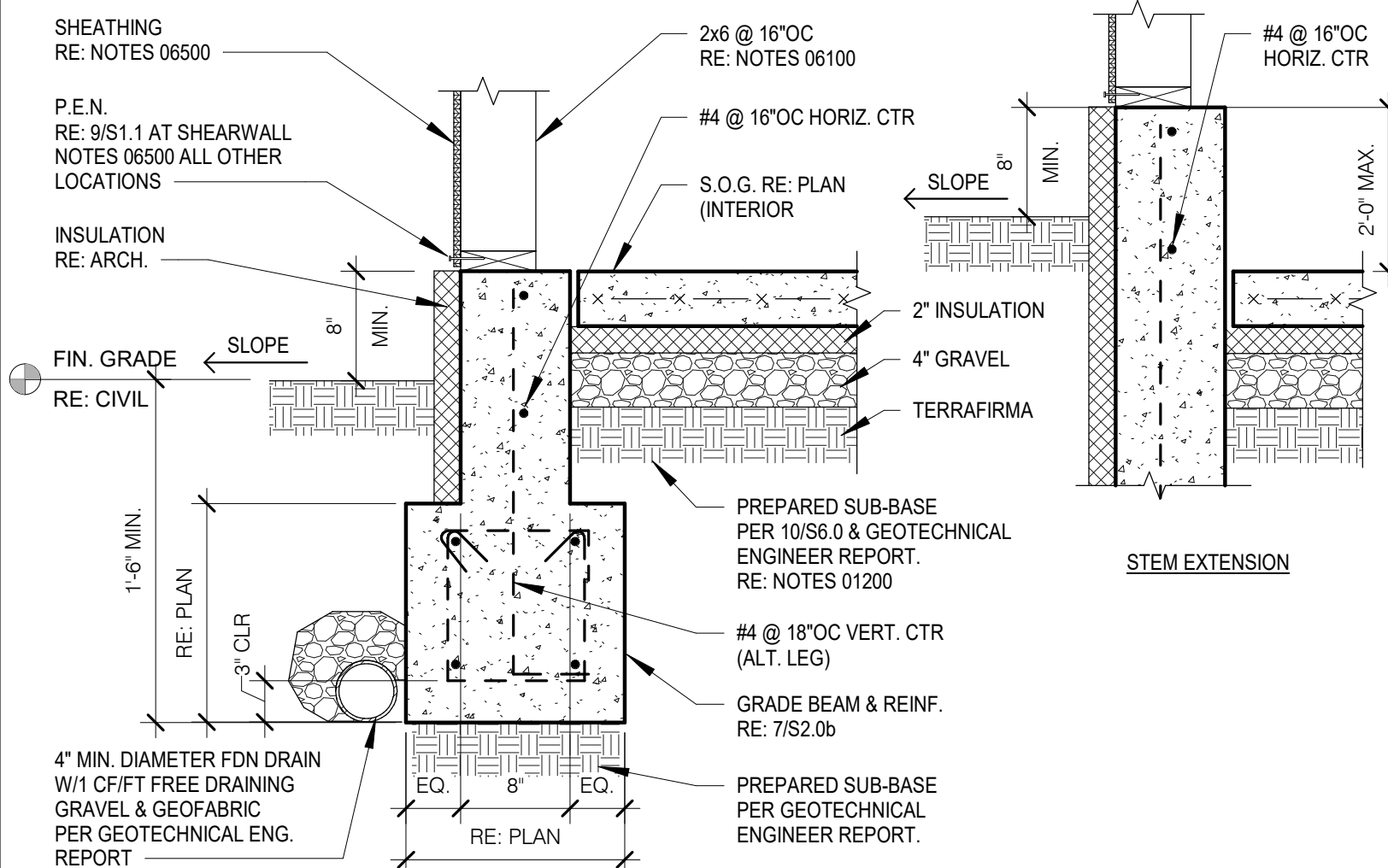

SCALE: 1" = 1'-0"
11 TYPICAL PERIMETER GRADEBEAM

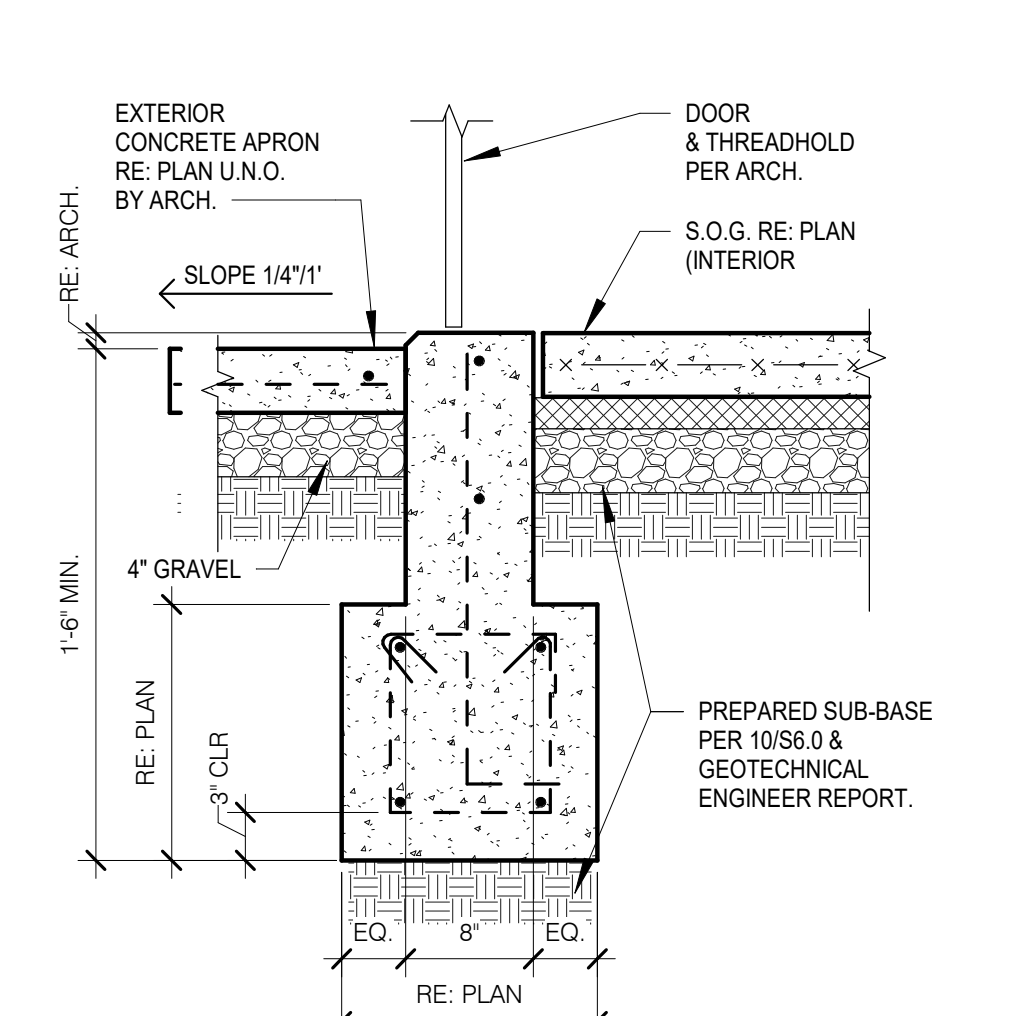

SCALE: 1" = 1'-0"
12 TYP. PERIMETER FTG AT OPENING

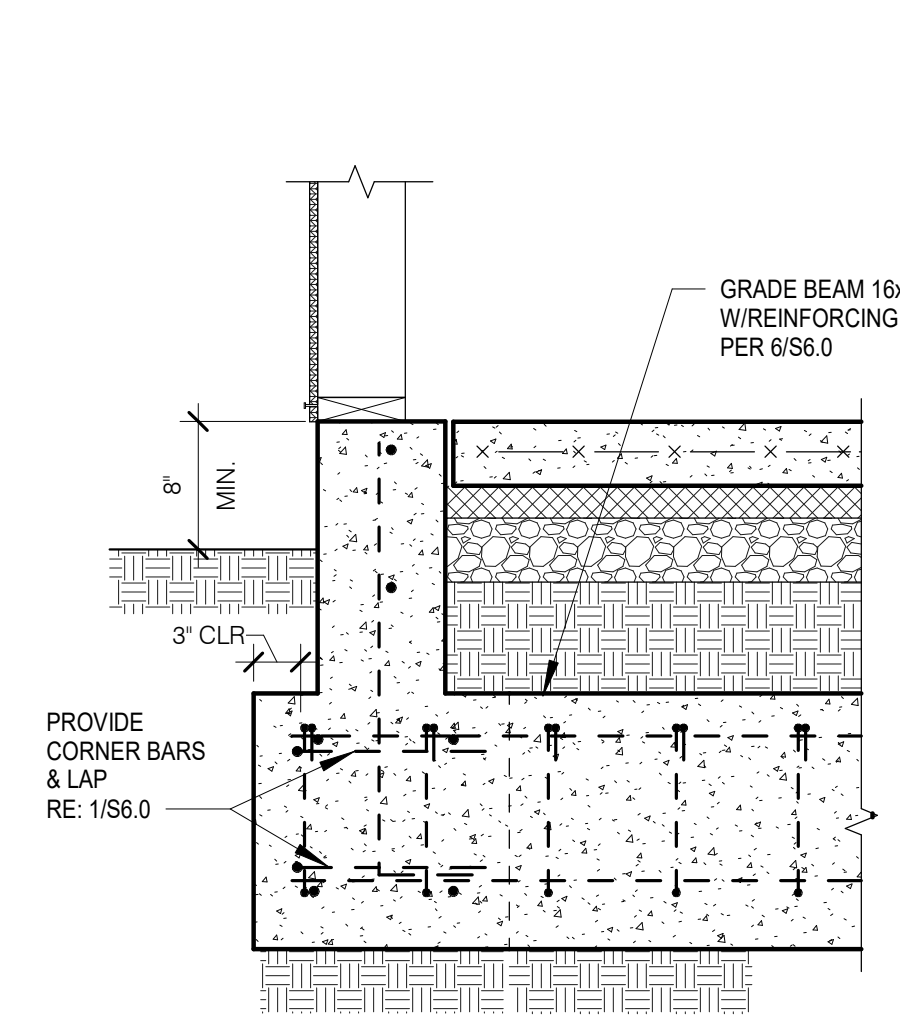

SCALE: 1" = 1'-0"
13 TYP. GRADE BEAM AT CORNER

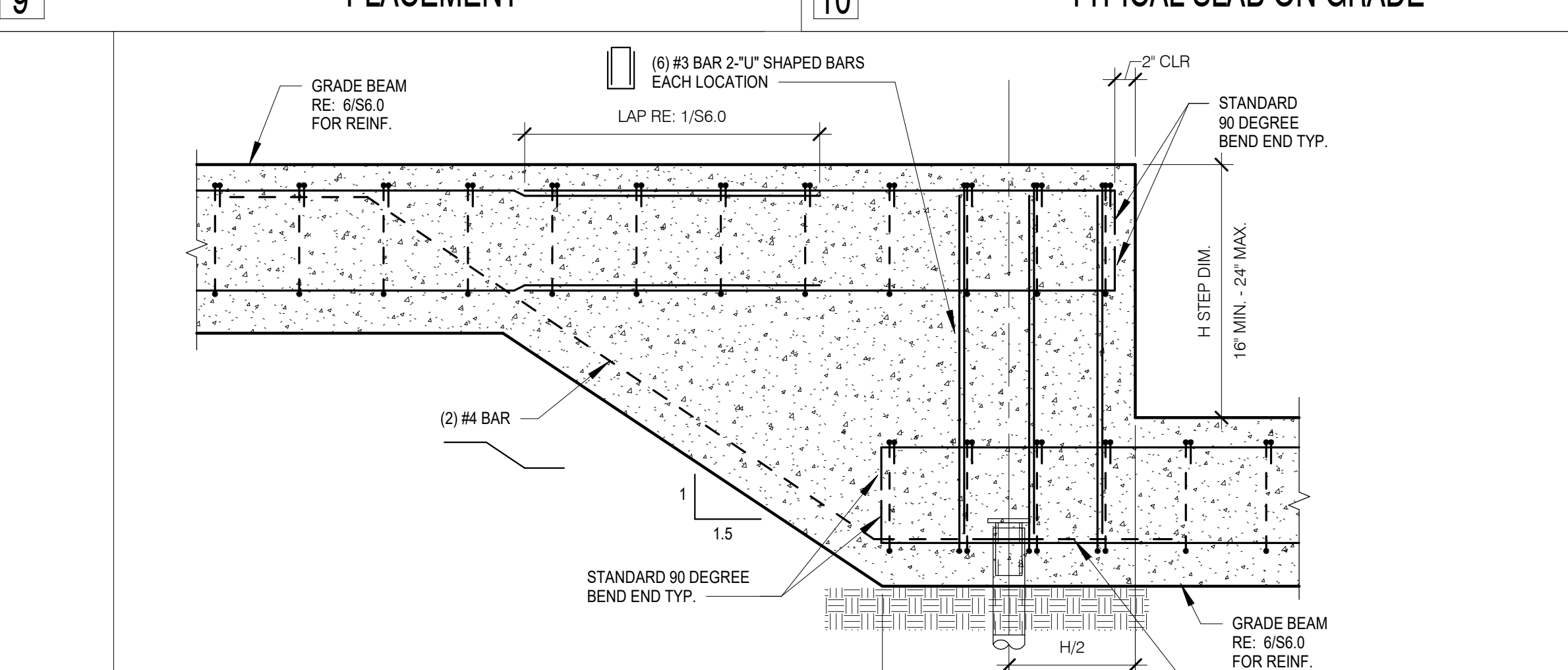

SCALE: 1" = 1'-0"
14 TYPICAL STEPPED GRADE BEAM

CT ENGINEERING INC.
Structural Engineers
180 N. Jackson Street, Suite 302, Seattle, WA 98109
206.285.4512 (V) 206.285.0616 (F)
www.ctengineering.com

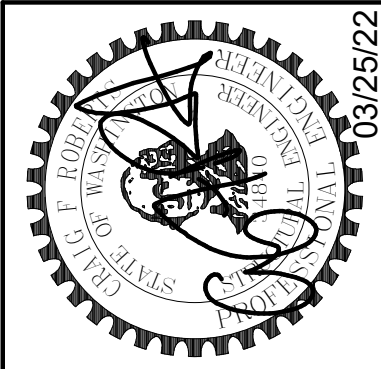

DATE	REVISION	No.

JOB #:	ENG.:	CAD.:	SCALE:	KEY ISSUE DATES:
21162	BJM	JMA	As Indicated	SD: SD CD: CD PD: PD PERMIT: 03/25/2022 OTHER: BD

Typical Concrete Details
PIPER REMODEL
8429 SE 33RD PLACE
MERCER ISLAND, WA 98040

S6.0

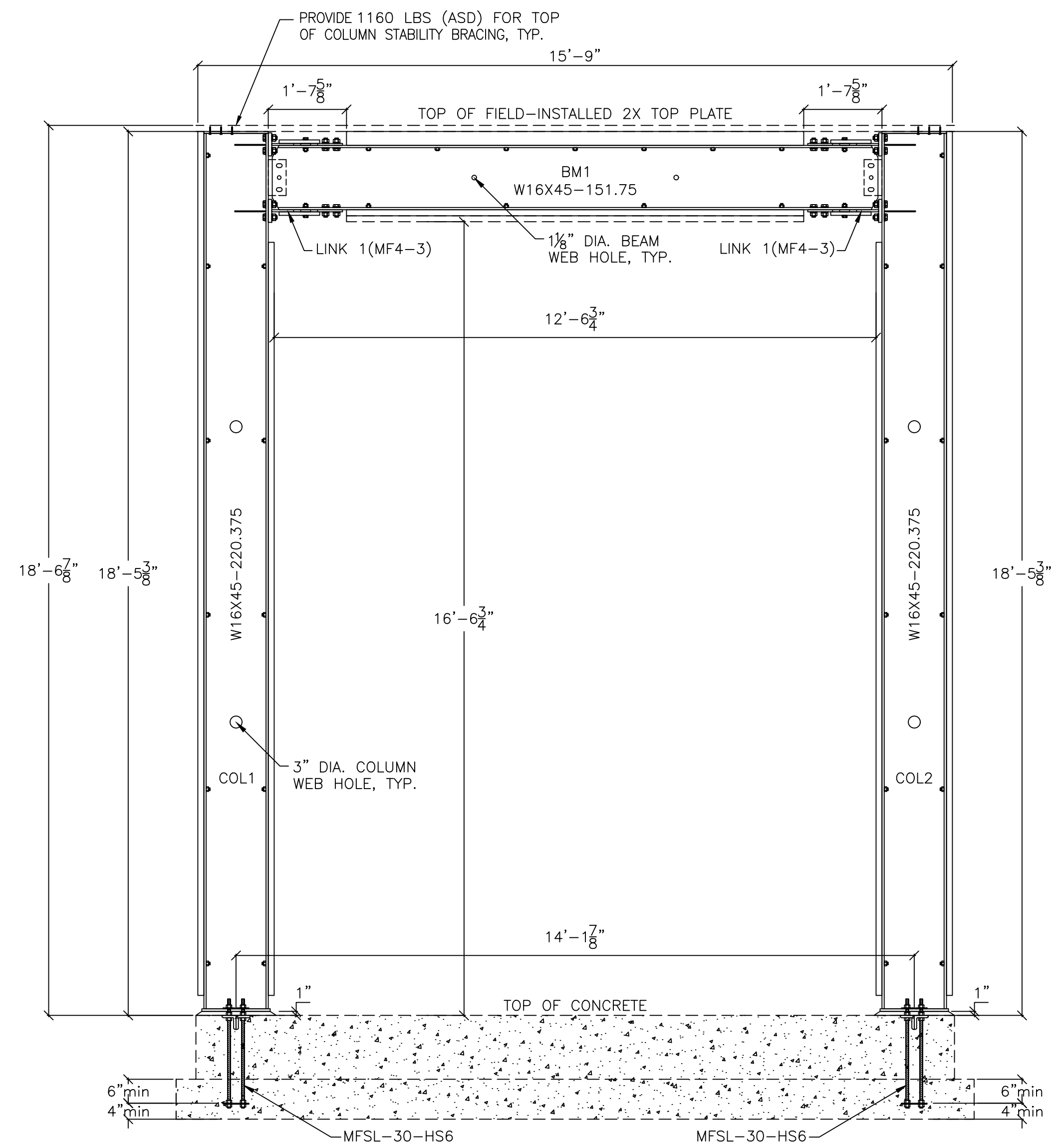

NOTE:
REFER TO GENERAL NOTES 9, 10, 11, AND 12 REGARDING
MINIMUM ANCHORAGE LENGTHS, ANCHORAGE EMBEDMENT, AND
FOOTING DIMENSIONS, REINFORCING, AND DESIGN.



GRADE BEAM PER DESIGNER
FRAME MODEL: SMF316z16-151.75x220.375-(MF4-3)

FRAME ELEVATION

SCALE: 1/2" = 1'-0"

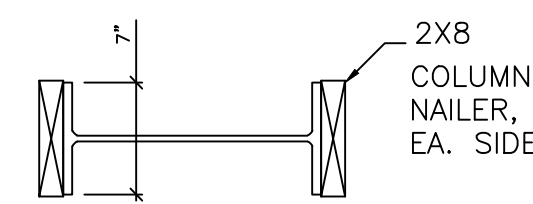

SECTION AT COLUMN 1

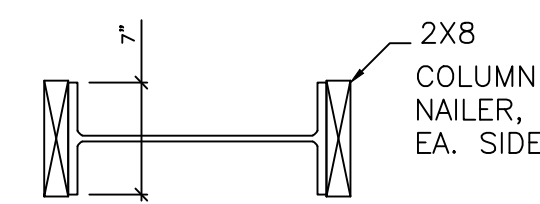

SECTION AT COLUMN 2

COLUMN SECTION

SCALE: 1" = 1'-0"

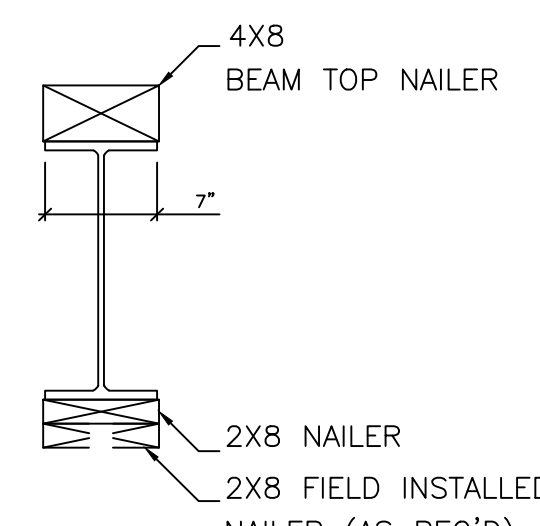

SECTION AT BEAM 1

BEAM SECTION

SCALE: 1" = 1'-0"

GENERAL NOTES:

- SIMPSON STRONG-TIE® STRONG FRAME® AND THE YIELD-LINK™ STRUCTURAL FUSE ARE PROTECTED UNDER ONE OR MORE OF THE FOLLOWING US PATENTS AND APPLICATIONS: US PATENT NO. 8,001,734 B2, US PATENT NO. 8,375,652 B2, AND US PATENT PUBLICATION NO. 2015/0159362, AND MUST BE SUPPLIED OR LICENSED THROUGH SIMPSON STRONG-TIE.
- STRONG FRAME® SPECIAL MOMENT FRAME IS MANUFACTURED AND TRADEMARKED BY "SIMPSON STRONG-TIE COMPANY INC." HOME OFFICE: 5956 W. LAS POSITAS BLVD., PLEASANTON, CA 94588 TEL: (800) 999-5099, FAX: (925) 847-1597. "SIMPSON STRONG-TIE COMPANY INC." IS AN ISO 9001 REGISTERED COMPANY.
- DESIGN FOR STRONG FRAME® MOMENT FRAMES ARE IN ACCORDANCE WITH THE FOLLOWING:
 - 2018, 2015 AND 2012 INTERNATIONAL BUILDING CODE
 - AISC SPECIFICATION FOR STRUCTURAL STEEL BUILDINGS (ANSI/AISC 360-05, 360-10, 360-16)
 - AISC SEISMIC PROVISIONS (ANSI/AISC 341-05, 341-10, 341-16)
 - RCSC SPECIFICATION FOR STRUCTURAL JOINTS USING ASTM A325 OR A490 BOLTS
 - BUILDING CODE REQUIREMENTS FOR STRUCTURAL CONCRETE (ACI318-11, ACI318-14)
- USE OF THIS PRODUCT IS SUBJECT TO THE APPROVAL OF THE LOCAL BUILDING DEPARTMENT.
- THIS PRODUCT IS PART OF THE OVERALL LATERAL FORCE RESISTING SYSTEM OF THE STRUCTURE. DESIGN OF THE BUILDING'S LATERAL FORCE RESISTING SYSTEM, INCLUDING THE LOAD PATH TO TRANSFER LATERAL FORCES FROM THE STRUCTURE TO THE GROUND, IS THE RESPONSIBILITY OF THE DESIGNER.
- THE DESIGNER MUST SPECIFY THE REQUIRED COMPONENTS OF THE COMPLETE LOAD TRANSFER PATH INCLUDING DIAPHRAGMS, SHEAR TRANSFER, CHORDS AND COLLECTORS AND FOUNDATIONS.
- ALL CONNECTED MEMBERS AND RELATED ELEMENTS SHALL BE DESIGNED BY THE DESIGNER.
- DESIGNER IS PERMITTED TO MODIFY DETAILS FOR SPECIFIC CONDITIONS. SEE LIMITATIONS NOTED ON SHEET SMF3.
- ANCHORAGE LENGTHS PROVIDED ARE SHOWN FOR MINIMUM EMBEDMENT INTO FOOTING BASED ON TENSION ANCHORAGE DESIGN ONLY. ACTUAL LENGTH OF ANCHORAGE SHALL BE PER DESIGNER'S SPECIFICATIONS AND PROJECT SPECIFIC INSTALLATION REQUIREMENTS.
- PRE-ASSEMBLED ANCHORAGE KITS PROVIDED BY SIMPSON (MFSL OR MFAB) SHALL BE SPECIFIED BY DESIGNER AND SHOULD INCLUDE ANCHORAGE TYPE, ROD GRADE, AND LENGTH OF ASSEMBLY. REFER TO DETAIL 2 FOR AVAILABLE LENGTHS OF FULLY ASSEMBLED ANCHORAGE ASSEMBLIES. EXTENSION KITS IN 36" LENGTHS ARE AVAILABLE FOR USE IN STEMWALLS OR APPLICATIONS WHERE DEEPER EMBEDMENT IS REQUIRED.
- FOOTING DIMENSIONS SHOWN ARE THE MINIMUMS REQUIRED FOR CONCRETE ANCHORAGE REQUIREMENTS ONLY. THE DESIGNER MUST DETERMINE REQUIRED FOOTING SIZE AND REINFORCING FOR OTHER DESIGN LIMITS, SUCH AS FOUNDATION SHEAR AND BENDING, SOIL BEARING SHEAR TRANSFER, AND FRAME STABILITY / OVERTURNING.
- DESIGNER MUST DETAIL ACTUAL FOOTING / GRADE BEAM SIZE AND REINFORCING.
- HOLES IN BASE PLATES ARE OVER-SIZED FOR ERECTION TOLERANCE. DESIGNER MUST EVALUATE EFFECTS OF OVER-SIZED HOLES AND PROVIDE PLATE WASHER WITH STANDARD-SIZE HOLES WELDED TO BASE PLATE OR REQUEST BASE PLATES WITH STANDARD SIZE HOLES WHERE REQUIRED.
- THE CONTRACTOR SHALL VERIFY ALL DIMENSIONS, CONDITIONS, ELEVATIONS, ETC. PRIOR TO INSTALLATION OF ANY COMPONENTS FOR THE STEEL STRONG FRAME SYSTEM. IF ANY DISCREPANCIES ARE FOUND, THEY SHALL BE BROUGHT TO THE ATTENTION OF THE DESIGNER FOR CLARIFICATION PRIOR TO CONSTRUCTION.
- INSTALLATION OF PRODUCT SHALL BE DONE IN CONFORMANCE WITH THESE DRAWINGS AND ICC ESR-2802. THE PERFORMANCE OF MODIFIED PRODUCTS OR ALTERED INSTALLATION PROCEDURES ARE THE SOLE RESPONSIBILITY OF THE DESIGNER.
- SIMPSON STRONG-TIE® COMPANY, INC. RESERVES THE RIGHT TO CHANGE SPECIFICATIONS, DESIGNS, AND MODELS WITHOUT NOTICE OR LIABILITY FOR SUCH CHANGES.
- ALL HARDWARE CALLED OUT IS SIMPSON STRONG-TIE®.
- USE OF A SIMPSON STRONG-TIE PRODUCT DOES NOT IMPLY THAT SIMPSON STRONG-TIE ENDORSES ANY PROJECT, STRUCTURE OR USE. NO LICENSE IS GRANTED WITH RESPECT TO ANY SIMPSON STRONG-TIE TRADEMARK OR OTHER INTELLECTUAL PROPERTY RIGHTS. WRITTEN PERMISSION MUST BE OBTAINED PRIOR TO USING ANY SIMPSON STRONG-TIE TRADEMARKS OR PROPRIETARY DOCUMENTS AND MATERIALS.
- SIMPSON STRONG-TIE IS NOT AFFILIATED WITH, AND DOES NOT SPONSOR OR ENDORSE, THE DESIGNER, INSTALLER OR USERS OF THIS DRAWING, NOR DOES SIMPSON STRONG-TIE HAVE ANY JOINT VENTURE, PARTNERSHIP, AGENCY, EMPLOYMENT OR FIDUCIARY RELATIONSHIP WITH SUCH PERSONS.

MATERIAL:

- BARS/PLATES: ASTM 572 GR. 50, ASTM A529 GR. 50, OR ASTM A1011 HSLAS GR. 50
- W-SECTIONS (HOT ROLLED SECTIONS): ASTM A992
- LINK TO COLUMN FLANGE HIGH STRENGTH BOLTS: 7/8" DIA. ASTM A325, TYPE 1 (SNUG-TIGHT)
- BRP TO BEAM FLANGE AND SHEAR PLATE TO BEAM WEB HIGH STRENGTH BOLTS: ASTM A325, TYPE 1 (SNUG-TIGHT)
- LINK TO BEAM FLANGE HIGH STRENGTH BOLTS: ASTM F2280 TWIST OFF TYPE (A490 EQUIVALENT) (PRETENSIONED)
- BEAM TOP FLANGE WOOD NAILER BOLT: ASTM A307 GR. A
- CARRIAGE BOLTS: ASTM A307 GR. A
- ANCHOR RODS: ASTM F1554 GR 36 OR A36 (MFAB, MFSL, AND MF-ATREXT-LS); ASTM A449 (MFAB-HS, MFSL-HS, AND MF-ATREXT-HS)
- GROUT: ASTM C1107, MINIMUM 5,000 PSI COMPRESSIVE STRENGTH

INSTALLATION AND FIELD MODIFICATIONS:

THESE GENERAL INSTRUCTIONS FOR THE INSTALLER ARE PROVIDED TO ENSURE PROPER SELECTION AND INSTALLATION OF SIMPSON STRONG-TIE COMPANY INC. PRODUCTS AND MUST BE FOLLOWED CAREFULLY. THESE GENERAL INSTRUCTIONS ARE IN ADDITION TO THE SPECIFIC INSTALLATION INSTRUCTIONS AND NOTES PROVIDED FOR EACH PARTICULAR PRODUCT, ALL OF WHICH SHOULD BE CONSULTED PRIOR TO AND DURING INSTALLATION OF SIMPSON STRONG-TIE COMPANY INC. PRODUCTS.

- PROPER PRODUCT INSTALLATION REQUIRES CAREFUL ATTENTION TO ALL NOTES AND INSTRUCTIONS. IN ADDITION TO THE NOTES, WARNINGS, AND INSTRUCTIONS PROVIDED IN THE CATALOG, INSTALLERS, DESIGNERS, ENGINEERS AND CONSUMERS SHOULD CONSULT THE SIMPSON STRONG-TIE COMPANY INC. WEBSITE AT WWW.STRONGTIE.COM TO OBTAIN ADDITIONAL INFORMATION FOR INSTALLATION, SPECIFICATIONS, CODE REPORTS, TECHNICAL FLIERS AND BULLETINS, FAQs, AND OTHER PERTINENT INFORMATION.
- PROVIDE TEMPORARY DIAGONAL BRACING OF STRONG FRAME® AS REQUIRED UNTIL FRAME IS TIED INTO THE FLOOR OR ROOF FRAMING ABOVE.
- USE PROPER SAFETY AND INSTALLATION EQUIPMENT DURING INSTALLATION OF STRONG FRAME®.
- ALL SPECIFIED FASTENERS MUST BE INSTALLED ACCORDING TO THE INSTRUCTIONS PROVIDED IN THE CATALOG, CODE REPORT, AND INSTALLATION DETAILS. INCORRECT FASTENER QUANTITY, SIZE, PLACEMENT, TYPE, MATERIAL, OR FINISH MAY CAUSE THE CONNECTION TO FAIL.
- FILL ALL FASTENER HOLES AS SPECIFIED IN THE INSTALLATION INSTRUCTIONS FOR THE SPECIFIED PRODUCT. INSTALL ALL FASTENERS BEFORE LOADING THE FRAME. SOME PRE-INSTALLED ITEMS MAY NOT USE ALL HOLES.
- NUTS SHALL BE INSTALLED SUCH THAT THE END OF THE THREADED ROD OR BOLT IS AT LEAST FLUSH WITH THE TOP OF THE NUT.
- REFER TO DETAIL 12/SMF3 FOR ALLOWABLE HOLE OPENINGS IN BEAM AND COLUMNS.
- REFER TO DETAIL 11/SMF3 FOR CONNECTION PROTECTED ZONE.
- WELDING SHALL BE IN ACCORDANCE WITH AWS D1.1 AND AWS D1.8 (AS APPLICABLE FOR SEISMIC). WELDS SHALL BE SPECIFIED BY THE DESIGNER. PROVIDE WELDING SPECIAL INSPECTION AS REQUIRED BY THE LOCAL BUILDING DEPARTMENT.

INSPECTIONS:

- WELDING OF FRAME MEMBERS AND APPLICABLE WELDING SPECIAL INSPECTIONS REQUIRED BY IBC SECTION 1707 ARE PERFORMED ON THE PREMISES OF A FABRICATOR REGISTERED AND APPROVED IN ACCORDANCE WITH THE REQUIREMENTS OF IBC SECTION 1704.2.5 FOR FABRICATOR APPROVAL.
- PRE-INSTALLATION VERIFICATION TESTING IS PERFORMED ON HIGH-STRENGTH FASTENER ASSEMBLIES.
- INSPECTION REQUIREMENTS OUTSIDE THE SHOP MANUFACTURING AND ASSEMBLY PROCESS SHALL BE IN ACCORDANCE WITH THE LOCAL CODE, BASED ON BUILDING OCCUPANCY, CONCRETE STRENGTH, REQUIREMENTS OF THE LOCAL BUILDING OFFICIAL, AND OTHER CONSIDERATIONS AND SHALL BE SPECIFIED BY THE DESIGNER.
- GROUTING UNDER COLUMN BASE PLATE MAY REQUIRE SPECIAL INSPECTION, CONTACT THE LOCAL BUILDING DEPARTMENT FOR COMPLIANCE REQUIREMENTS.
- CONTACT SIMPSON STRONG-TIE® AT 800-999-5099 TO REQUEST PRE-INSTALLATION TESTING, WELDING REPORTS, MILL CERTS, ETC. WHEN REQUIRED.

GENERAL NOTES

1

MODEL NO.	ROD SIZE & NUMBER	LENGTH (in)	l _e (in)	BEARING PLATE (in)
MFSL-14-6	4 - 3/4	14	8 1/2	3/8" x 7" x 7"
MFSL-14-HS6	4 - 3/4	14	8 1/2	
MFSL-18-6	4 - 3/4	18	12 1/2	
MFSL-18-HS6	4 - 3/4	18	12 1/2	
MFSL-24-6	4 - 3/4	24	18 1/2	
MFSL-24-HS6	4 - 3/4	24	18 1/2	
MFSL-30-6	4 - 3/4	30	24 1/2	
MFSL-30-HS6	4 - 3/4	30	24 1/2	
MFSL-36-6	4 - 3/4	36	30 1/2	
MFSL-36-HS6	4 - 3/4	36	30 1/2	

THE MFSL ANCHOR ASSEMBLIES HAVE BEEN ENGINEERED TO PROVIDE A COMPLETE ANCHORAGE SOLUTION MEETING THE 2012 AND 2015, 2018 INTERNATIONAL BUILDING CODE REQUIREMENTS FOR BOTH TENSION AND SHEAR.

ANCHOR RODS AND THE MFTPL TEMPLATE ARE INCLUDED PRE-ATTACHED WITH THE ASSEMBLY.

INSPECTION IS EASY; THE HEAD IS STAMPED WITH A "NO EQUAL" SYMBOL FOR IDENTIFICATION, BOLT LENGTH, BOLT DIAMETER, AND OPTIONAL "HS" FOR HIGH STRENGTH IF SPECIFIED.

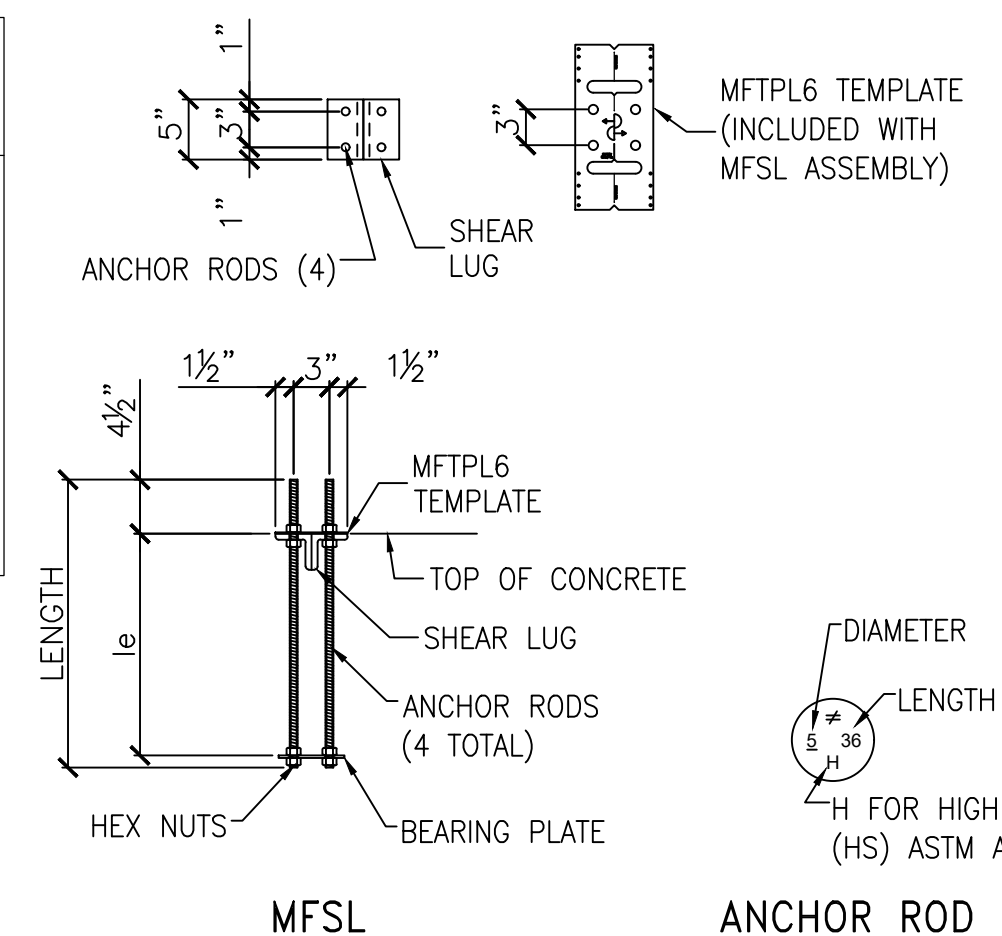

MFSL

ANCHOR ROD STAMP

MFSL ANCHORAGE ASSEMBLIES

2

DATE: 03/04/22
REVISION: 03/04/22
No. 03/04/22
JOB #: 21162
ENG: Designer
CAD: Author
SCALE:
KEY ISSUE DATES:
ISSUED: 03/04/22
REVISED: 03/04/22
OTHER: 03/04/22

Simpson Strong-Tie® Strong Frame® and the Yield-Link™ structural fuse are protected under one or more of the following US patents and applications: US patent No. 8,001,734 B2, US patent No. 8,375,652 B2, and US patent publication No. 2015/0159362, and must be supplied or licensed through Simpson Strong-Tie.

Moment Frame Details
PIPER REMODEL
8429 SE 33RD PLACE
MERCER ISLAND, WA 98040

S8.0

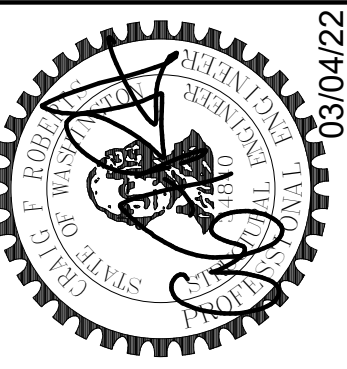

CT ENGINEERING INC.
Structural Engineers
180 Neckerson Street, Suite 302, Seattle, WA 98109
206.285.4572 (V) 206.285.0616 (F)
www.ctengineering.com

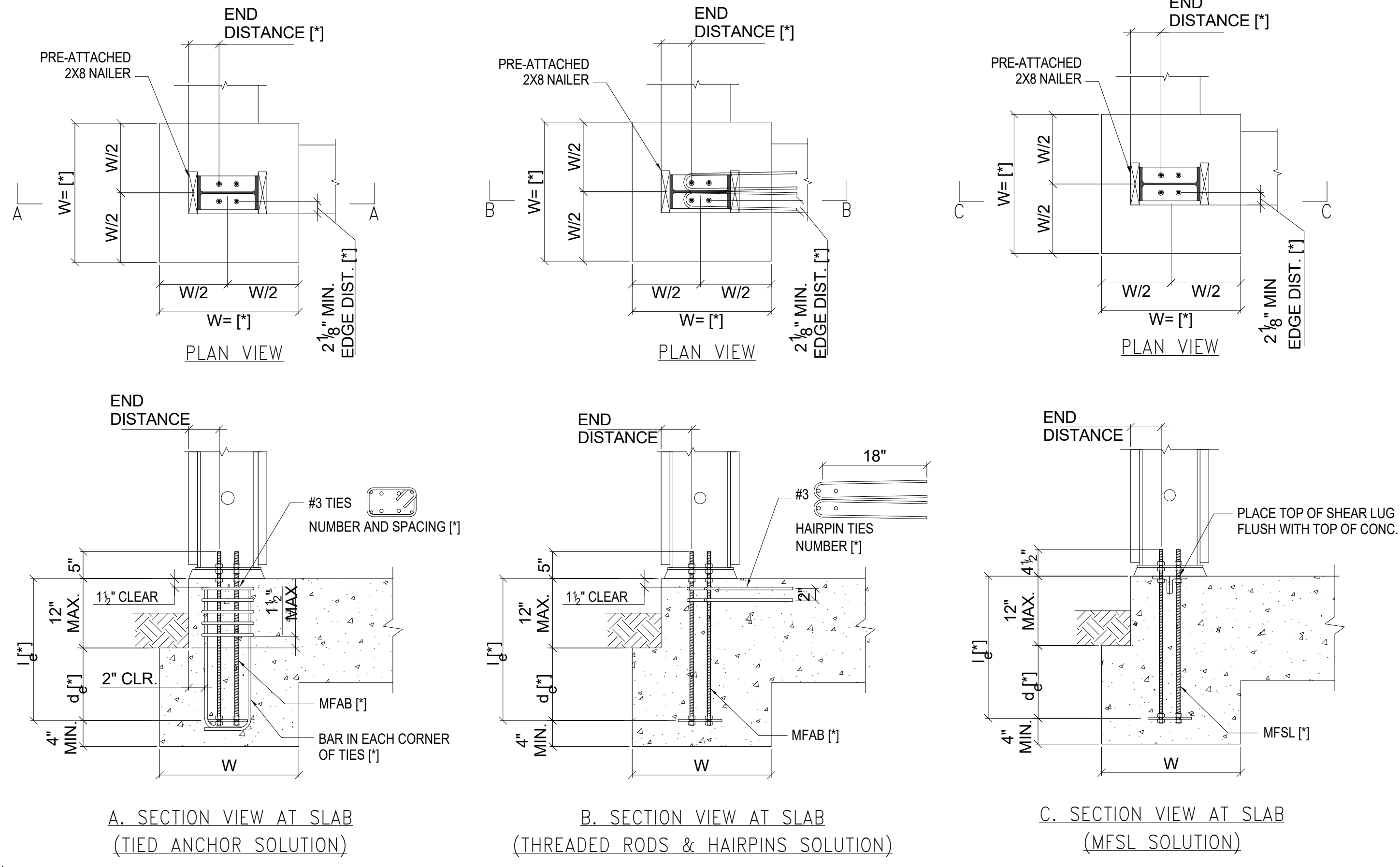

NOTES:
 1. [] DENOTES INFORMATION TO BE PROVIDED BY DESIGNER
 2. FOOTING/GRADE BEAM SIZE AND REINFORCING SHALL BE SPECIFIED BY THE DESIGNER AS REQUIRED TO RESIST IMPOSED LOADS, SUCH AS FOUNDATION SHEAR AND BENDING, SOIL BEARING PRESSURE, SHEAR TRANSFER, AND FRAME STABILITY/OVERTURNING

SLAB-ON-GRADE FOUNDATION ANCHORAGE DETAILS

1

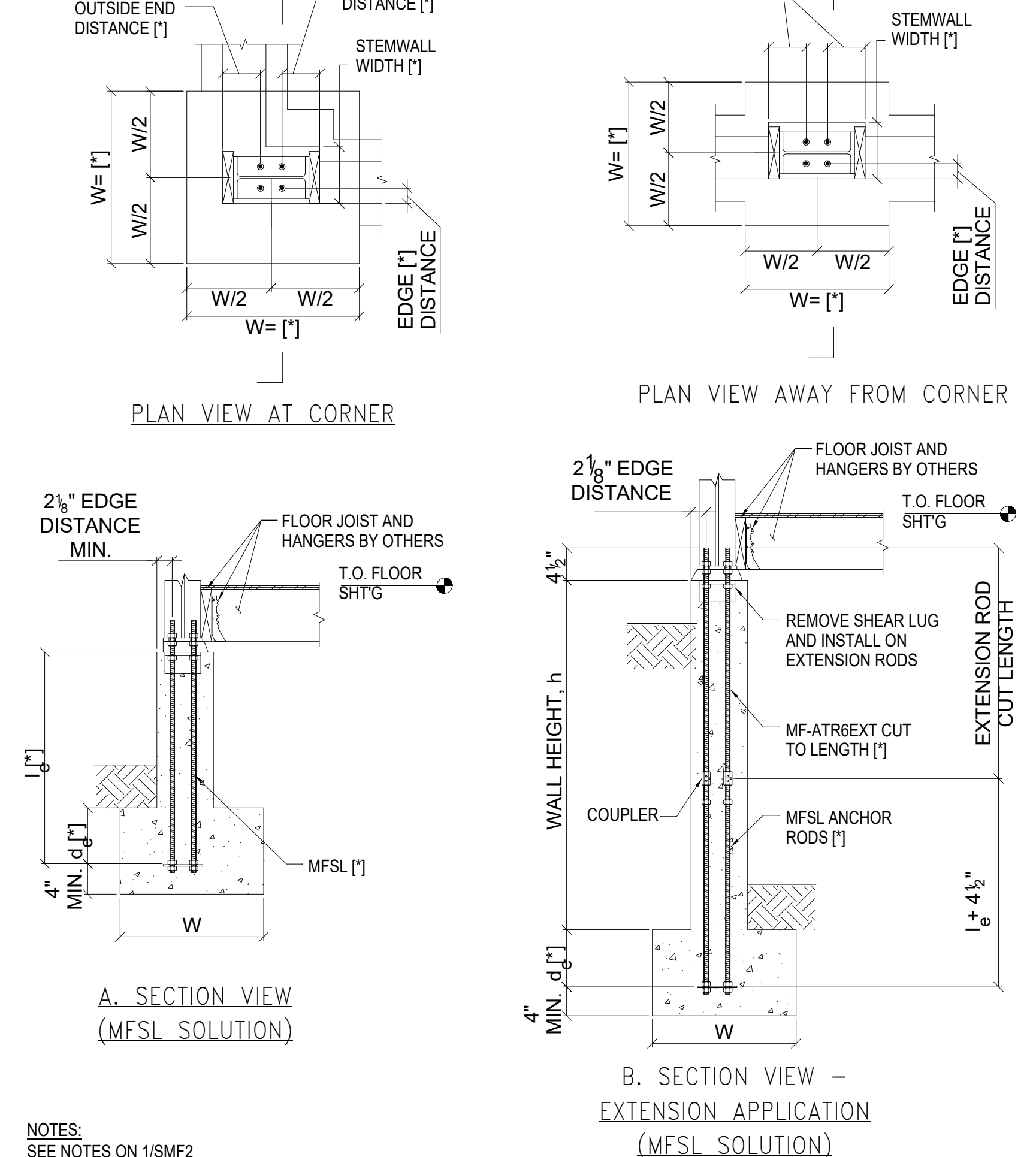

NOTES:
 SEE NOTES ON 1/SMF2

STEMWALL FOUNDATION ANCHORAGE DETAILS

3

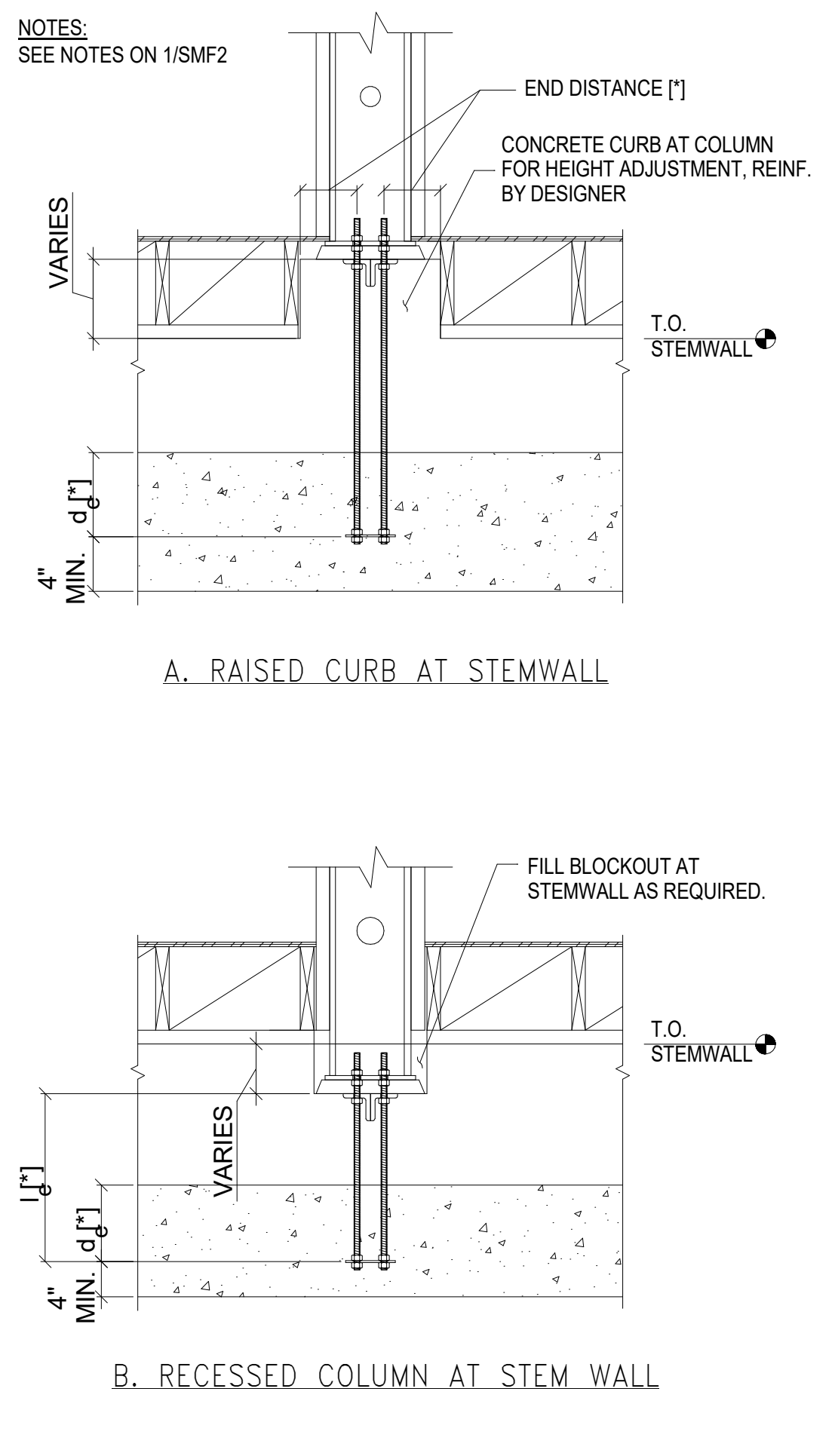

NOTES:
 SEE NOTES ON 1/SMF2

COL. HEIGHT ADJ. AT STEMWALL

6

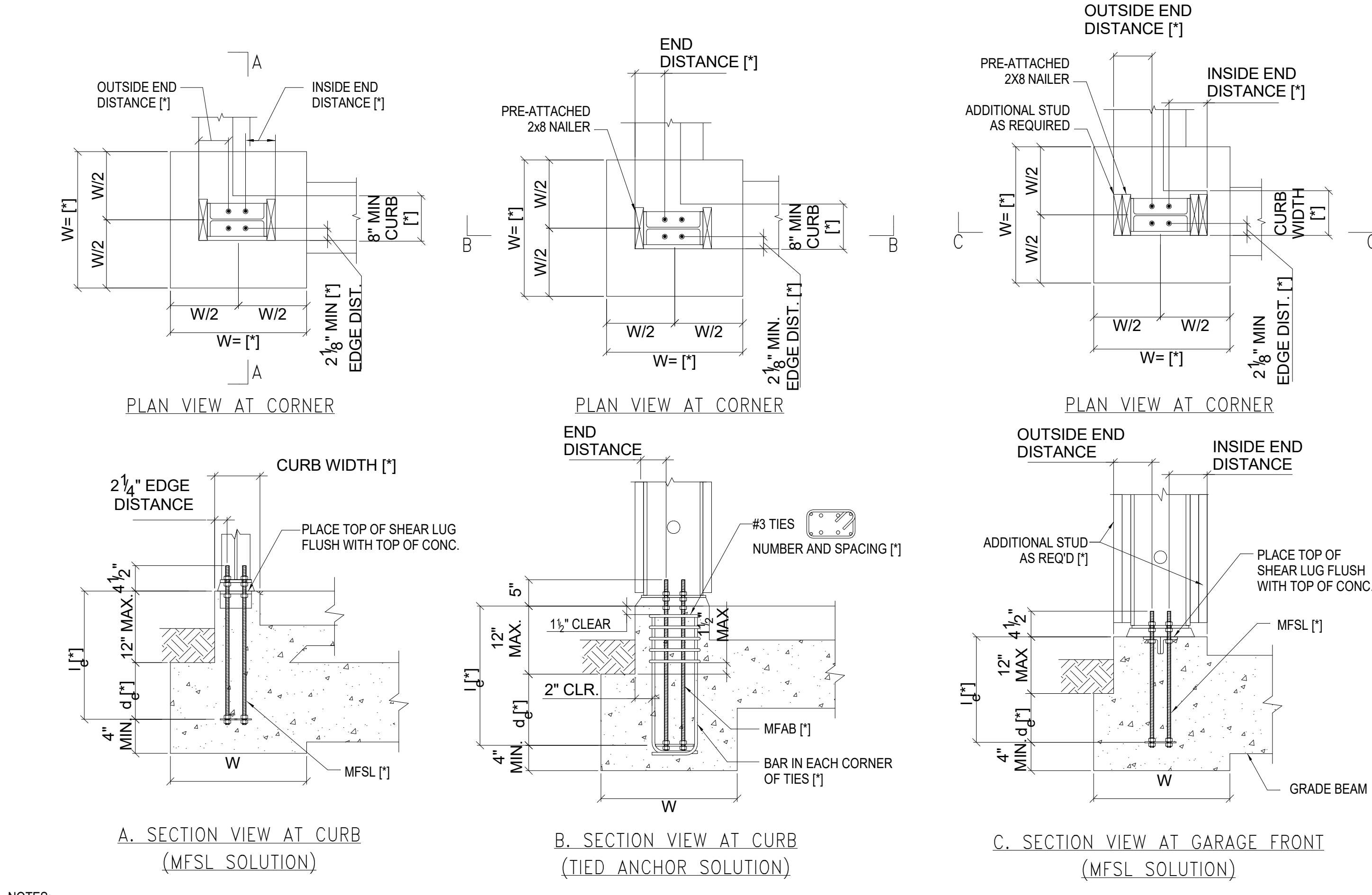

NOTES:
 SEE NOTES ON 1/SMF2

CONCRETE CURB FOUNDATION ANCHORAGE DETAILS

2

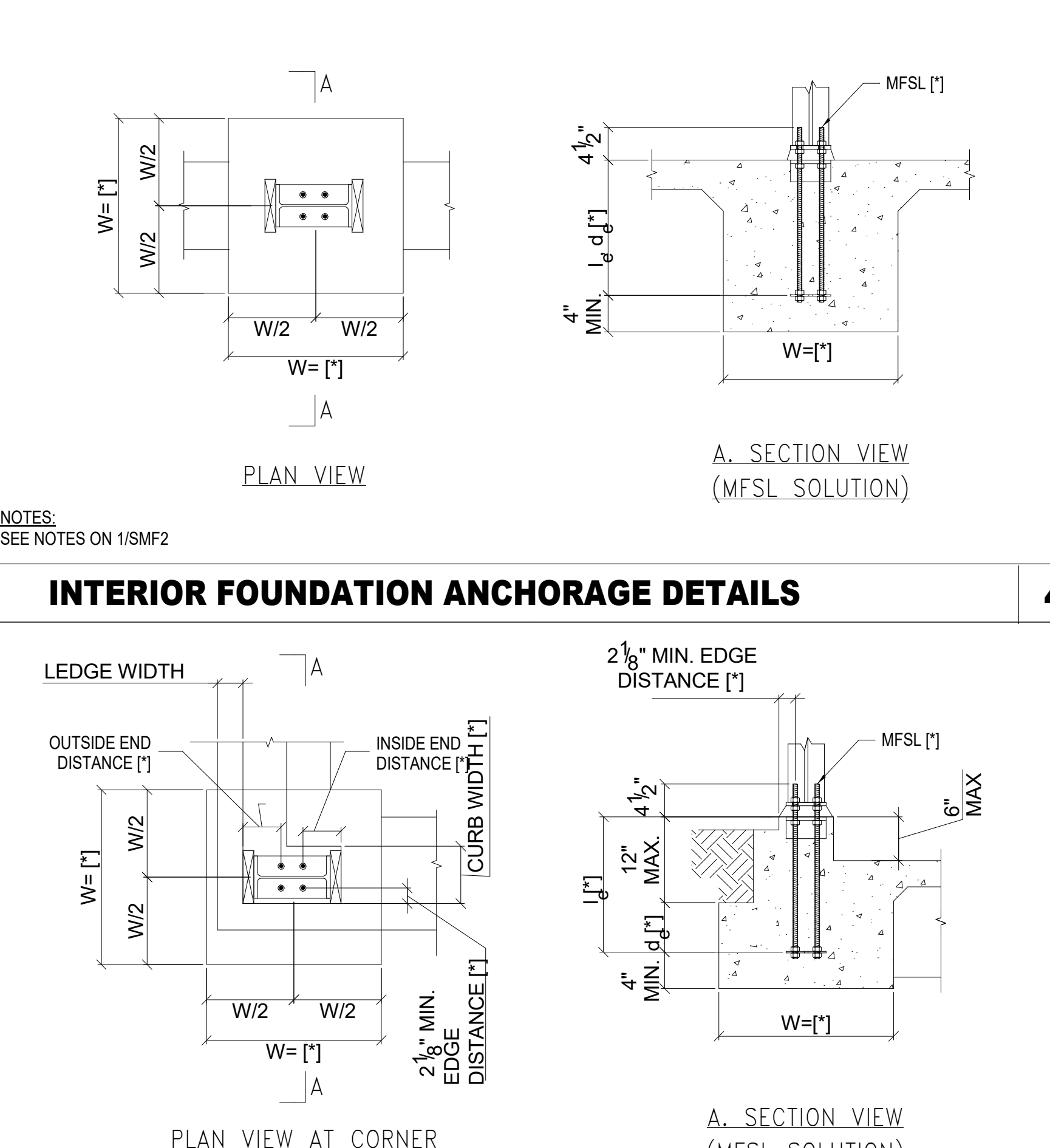

NOTES:
 SEE NOTES ON 1/SMF2

BRICK LEDGE FOUNDATION ANCHORAGE DETAILS

5

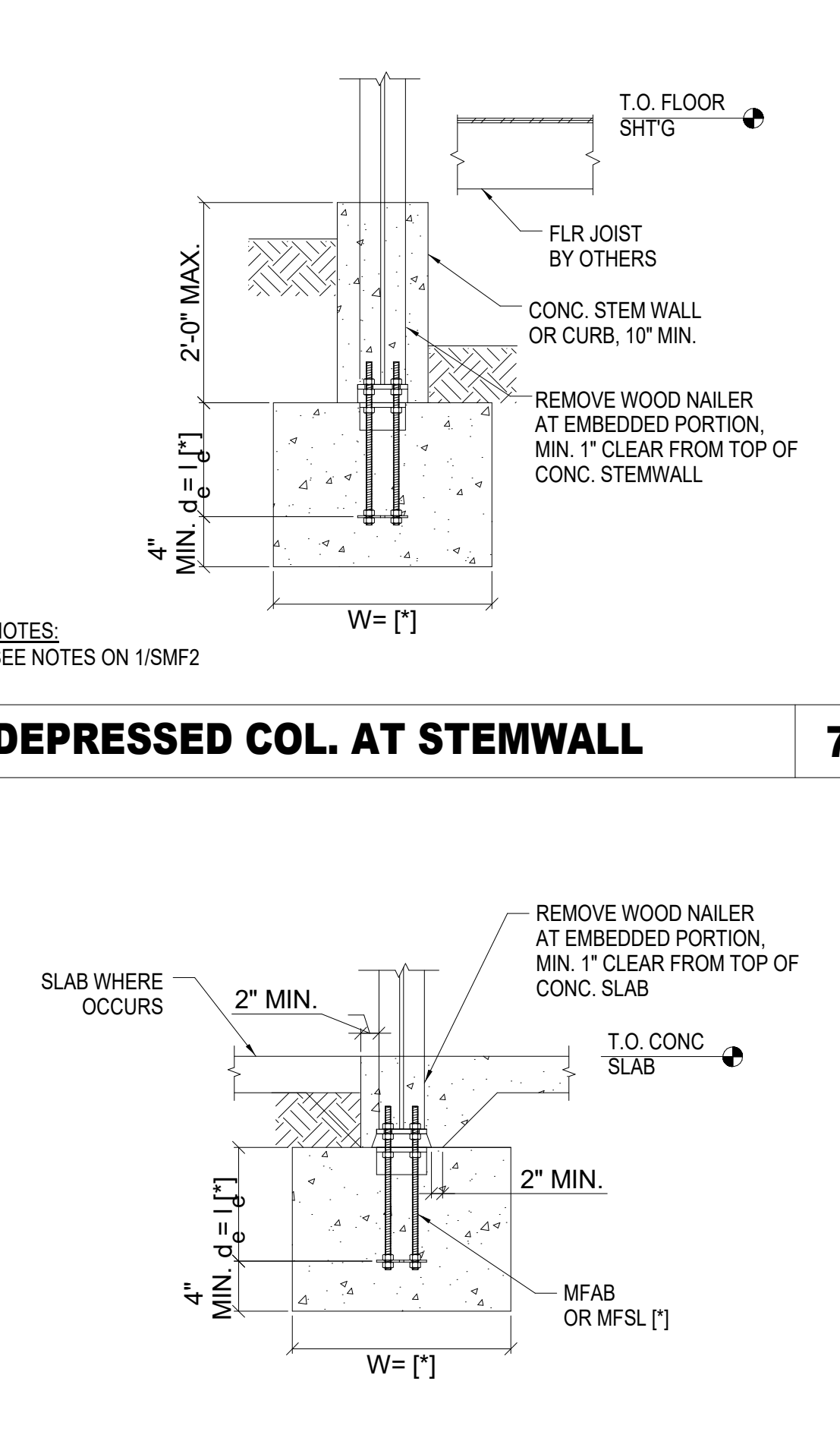

NOTES:
 SEE NOTES ON 1/SMF2

DEPRESSED COL. AT S.O.G.

8

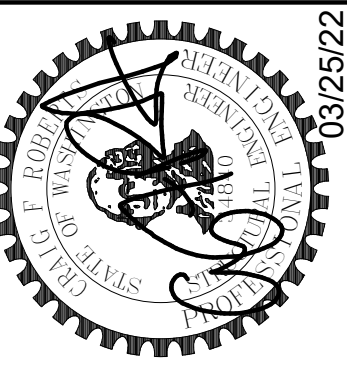

DATE	
REVISION	
No.	

JOB #:	21162
ENG.:	BJM
CAD.:	JMA
SCALE:	3/4" = 1'-0"
KEY ISSUE DATES:	
SD:	SD
CD:	CD
PERMIT:	03.25.2022
OTHER:	BD

2/21/2022 4:28:04 PM
 C:\Users\BJM\Desktop\Address\STRUCT1162.Piper_Remodel\Address (R) (1).rvt

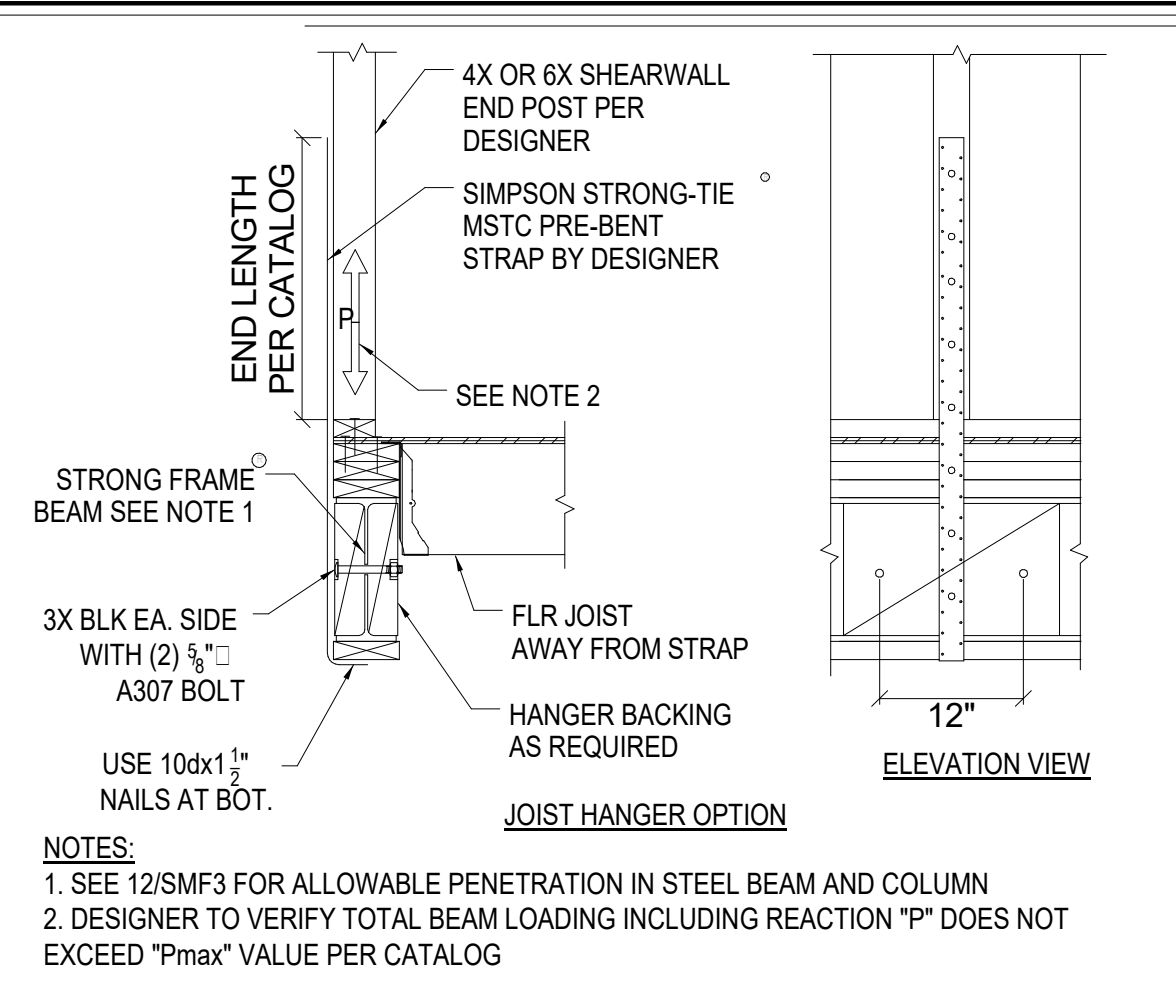

HOLDOWN POST TO SMF BEAM 1

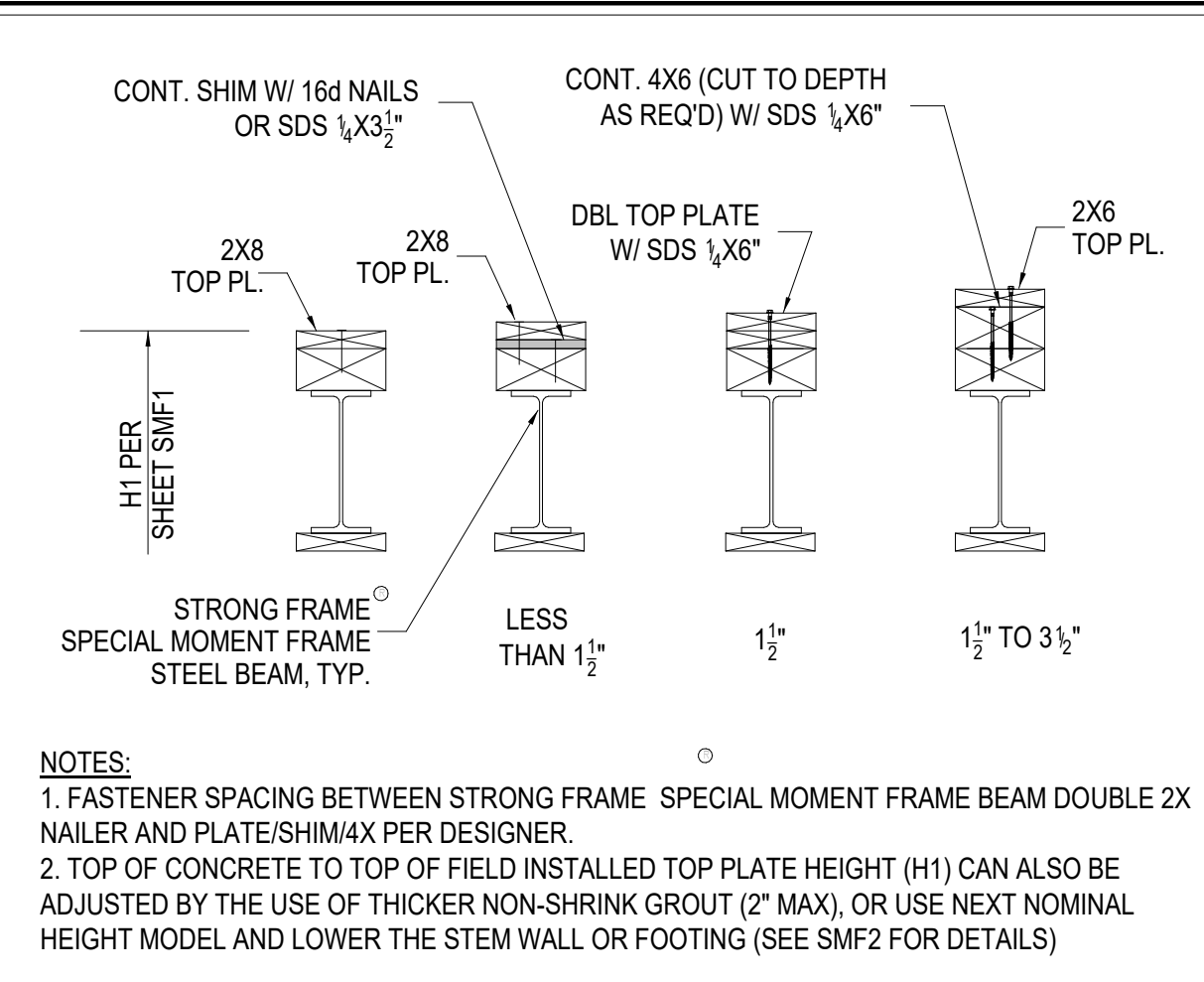

TOP OF FRAME ADJUSTMENT 5

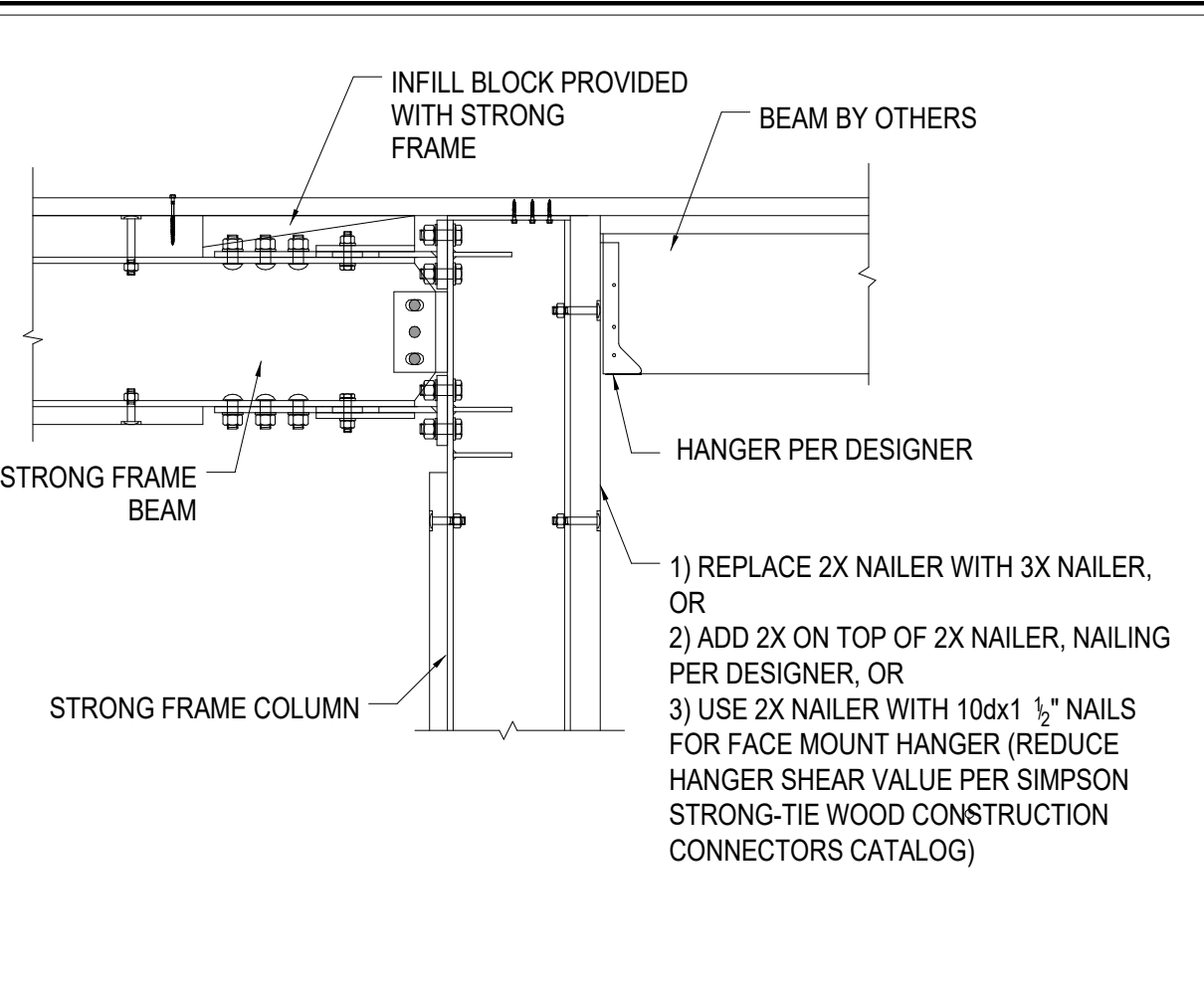

WOOD BM TO SMF COL. CONN. 8

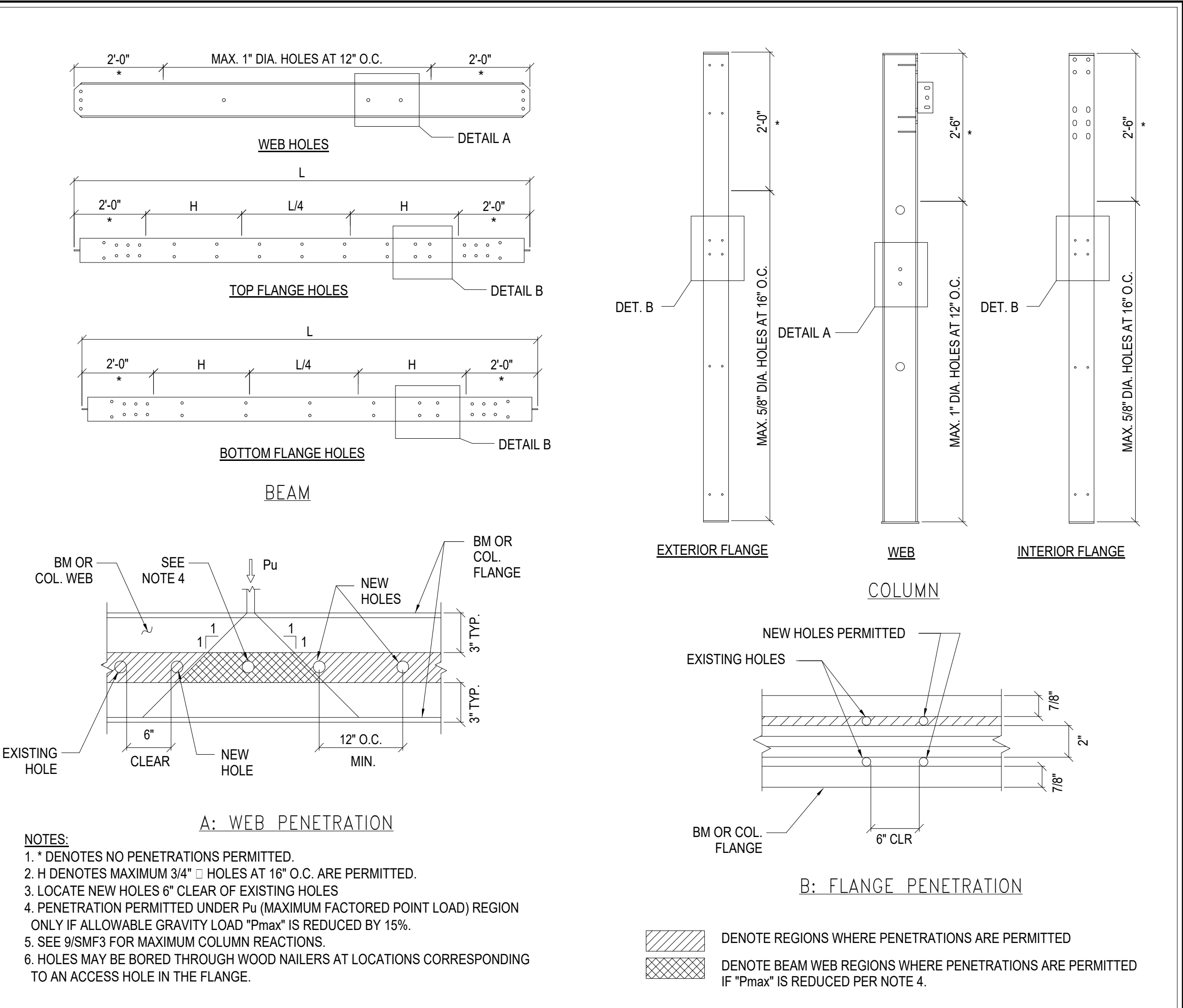

ALLOWABLE BEAM AND COLUMN PENETRATIONS 12

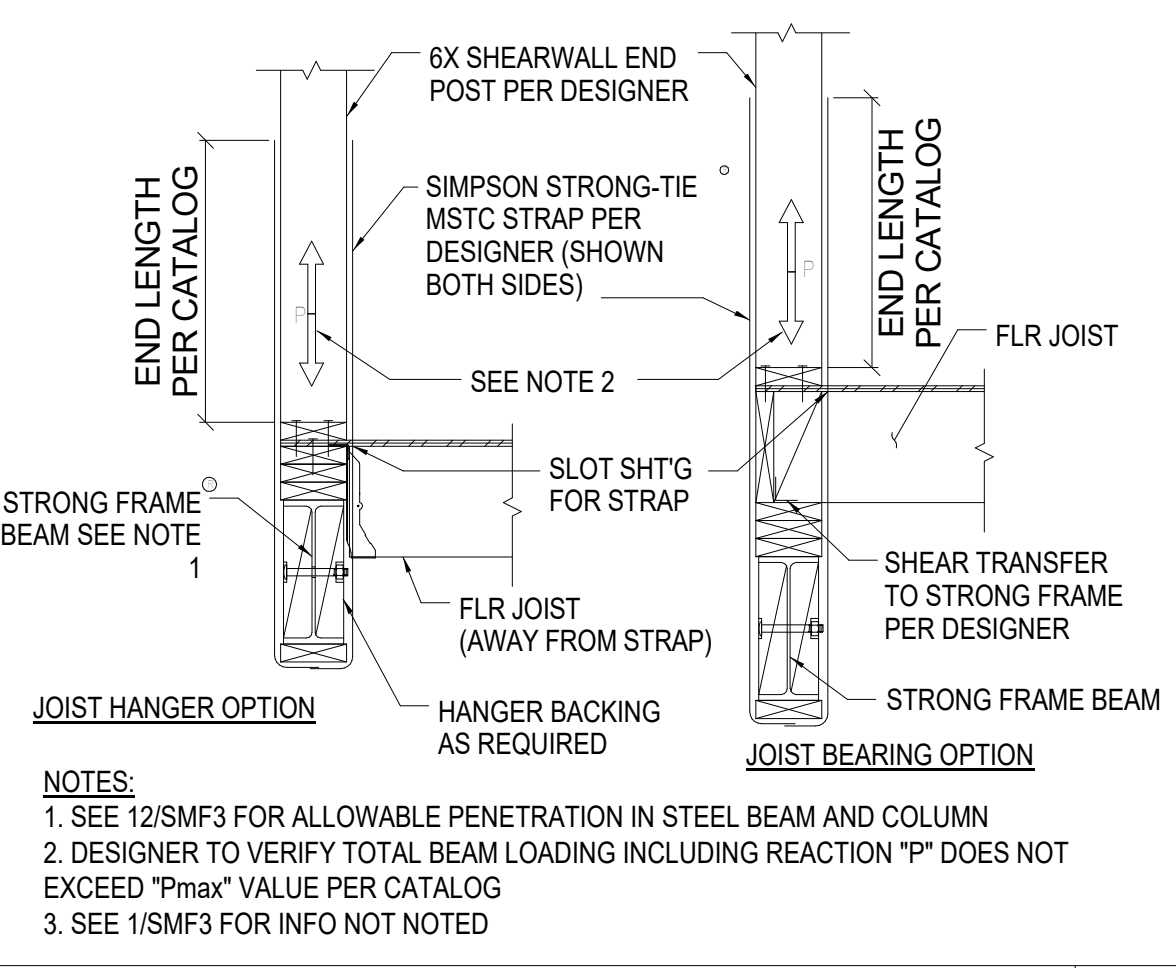

6x HOLDOWN POST TO SMF BEAM 2

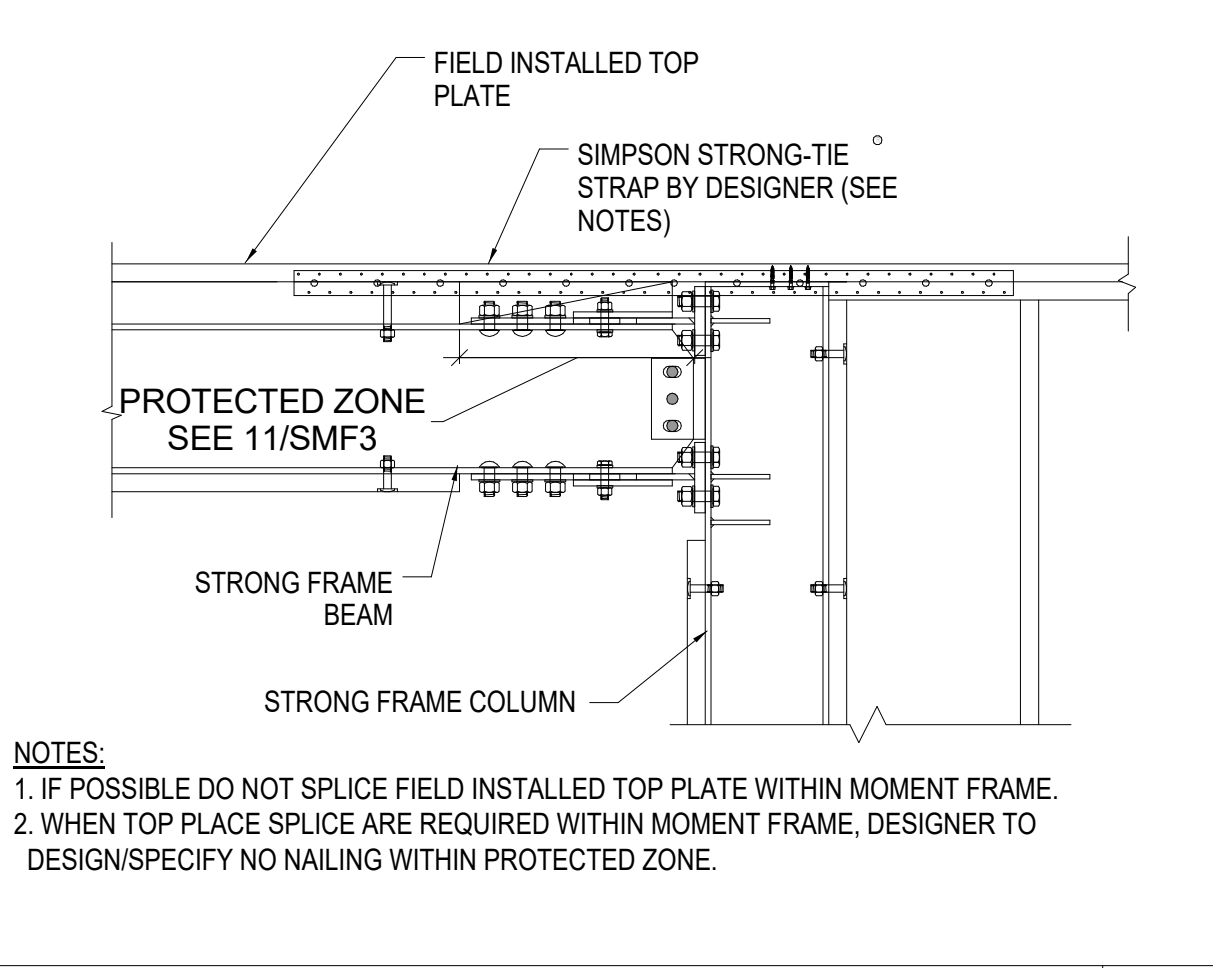

TOP PLATE SPLICE DETAIL 6

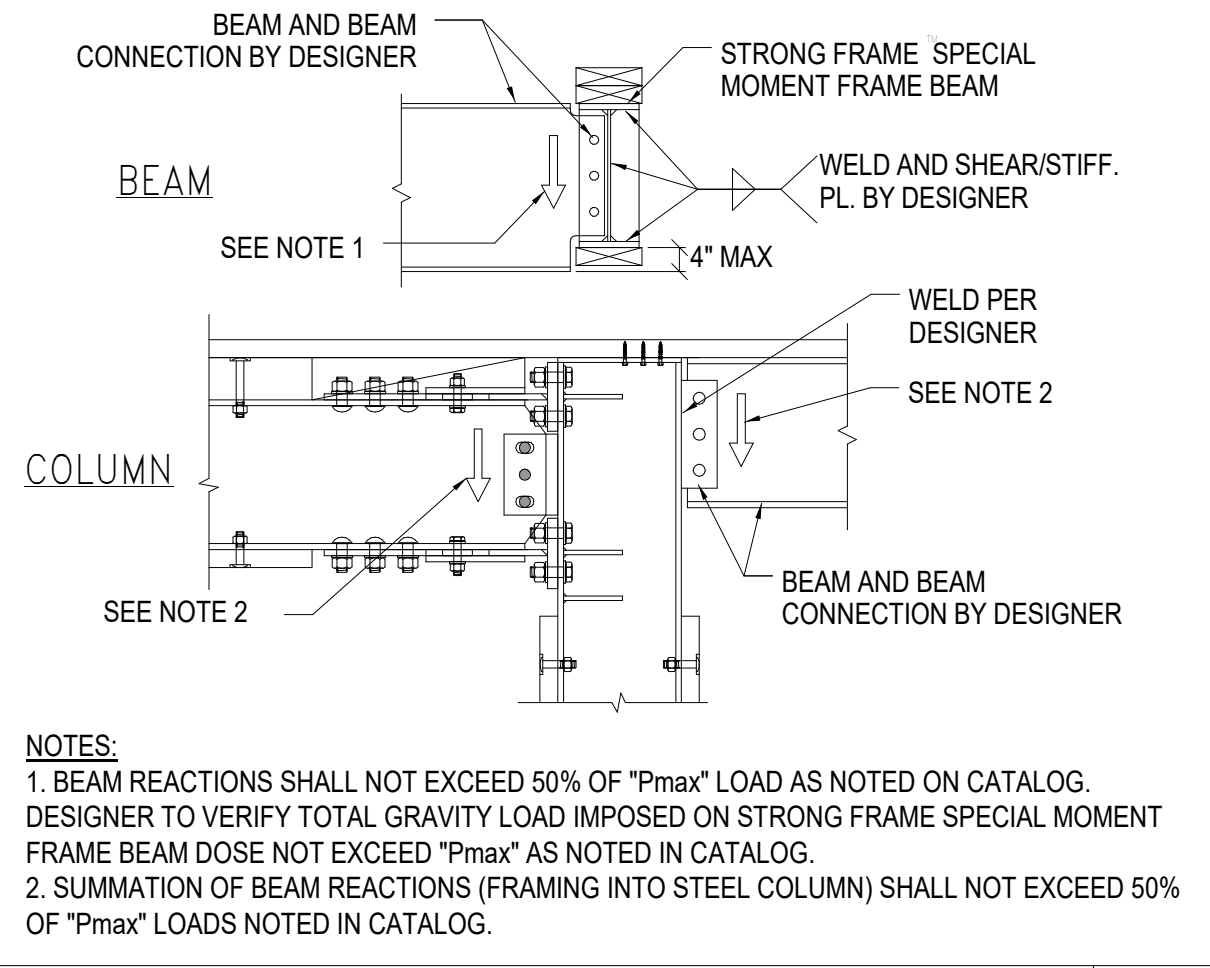

STEEL BEAM TO SMF BEAM/COL. 9

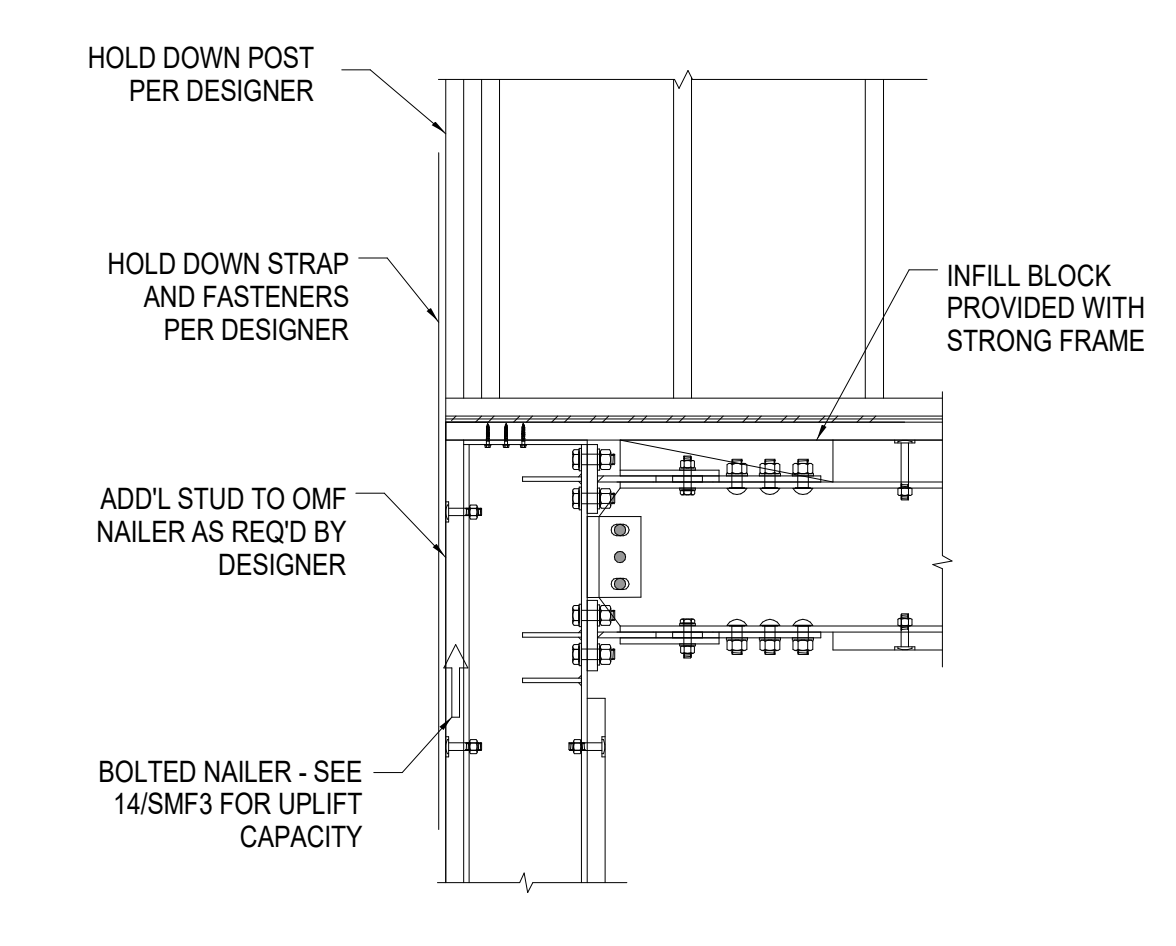

HOLDOWN POST TO SMF COL. 3

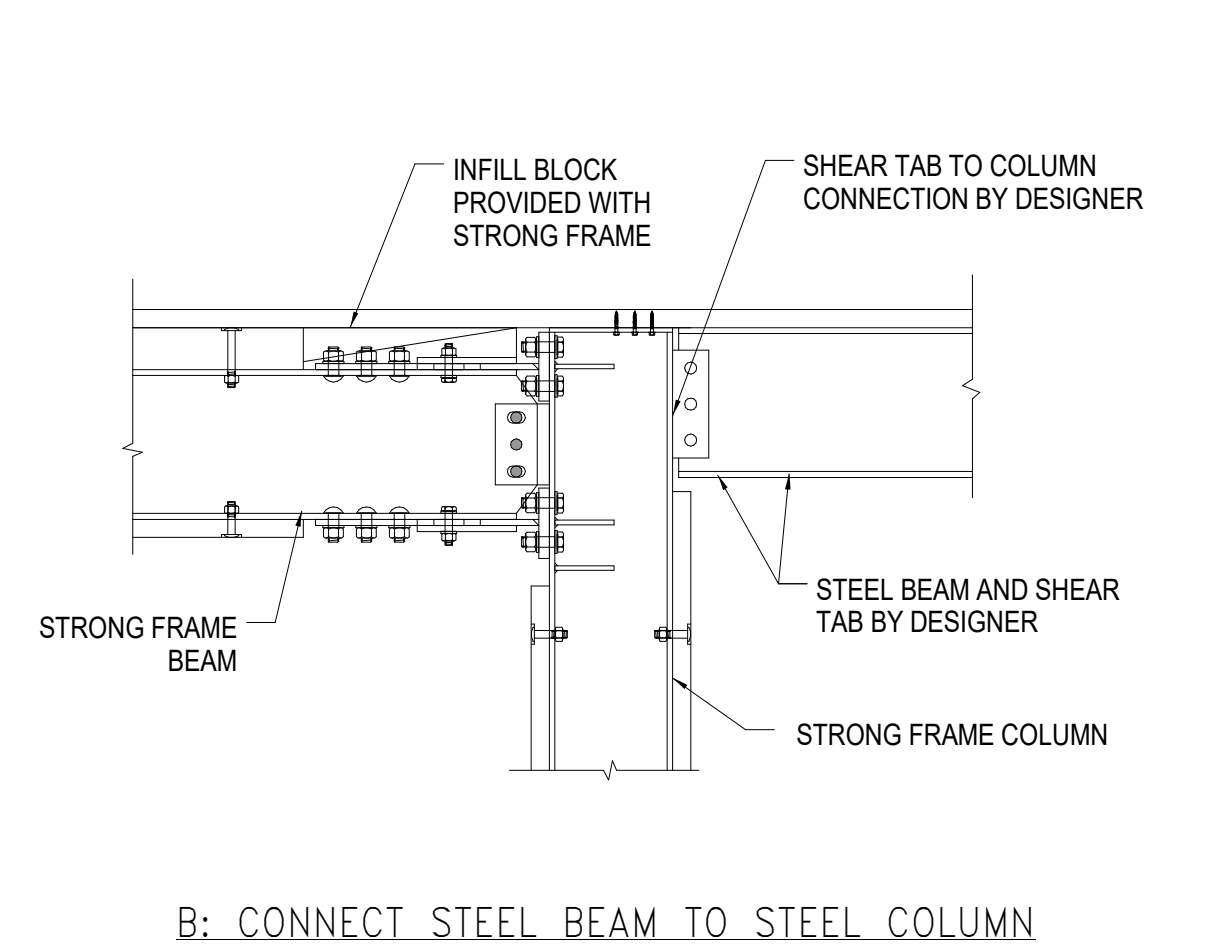

B: CONNECT STEEL BEAM TO STEEL COLUMN

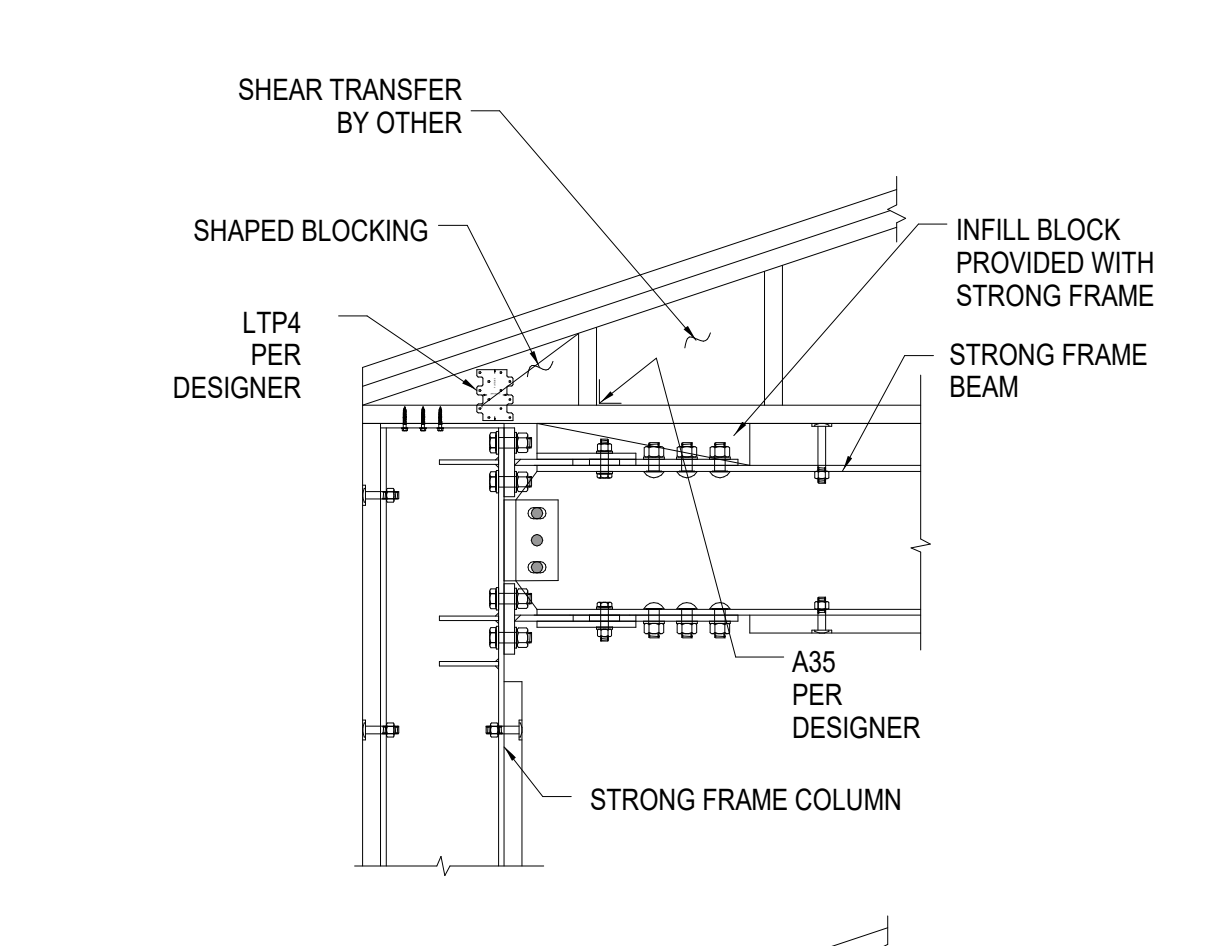

PROTECTED ZONE 11

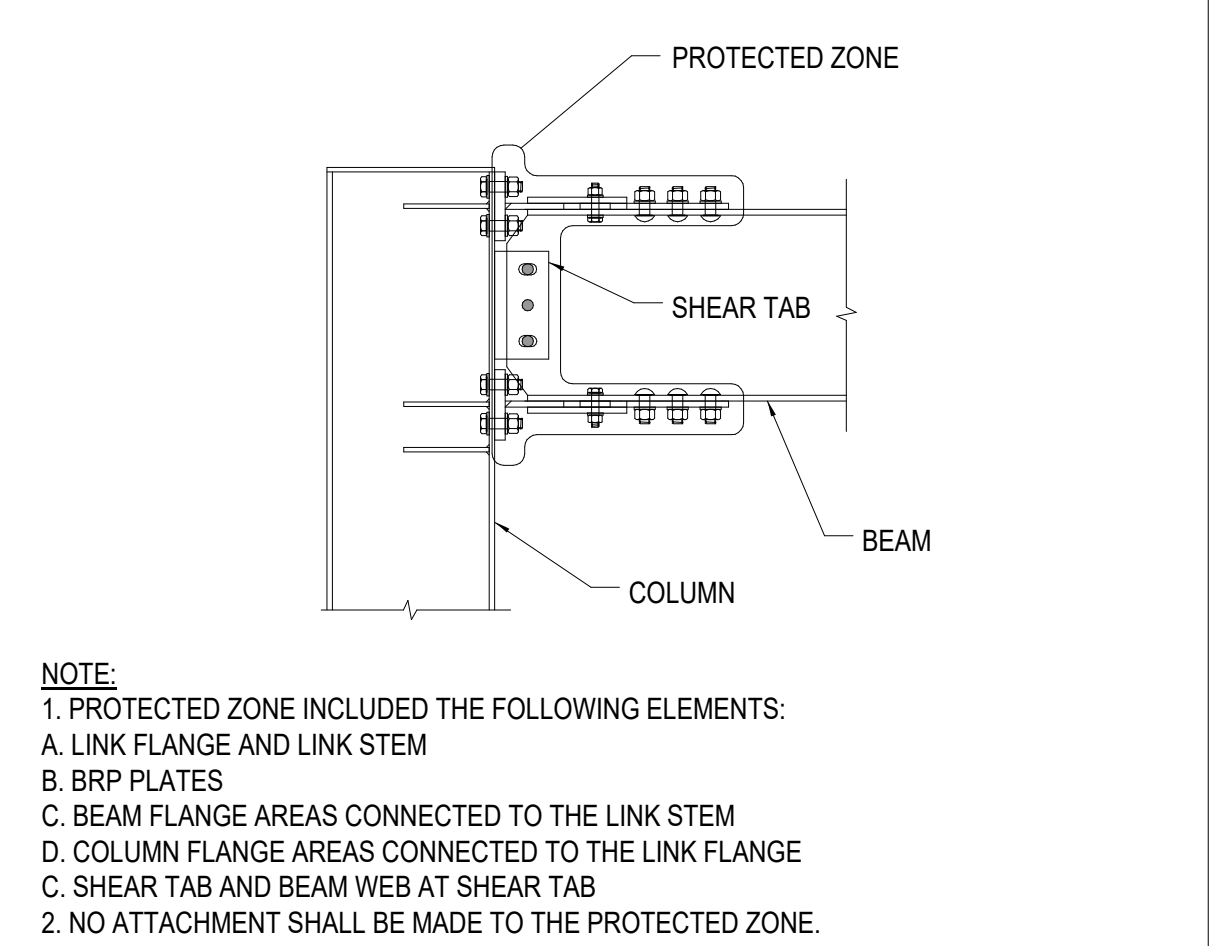

PROTECTED ZONE 11

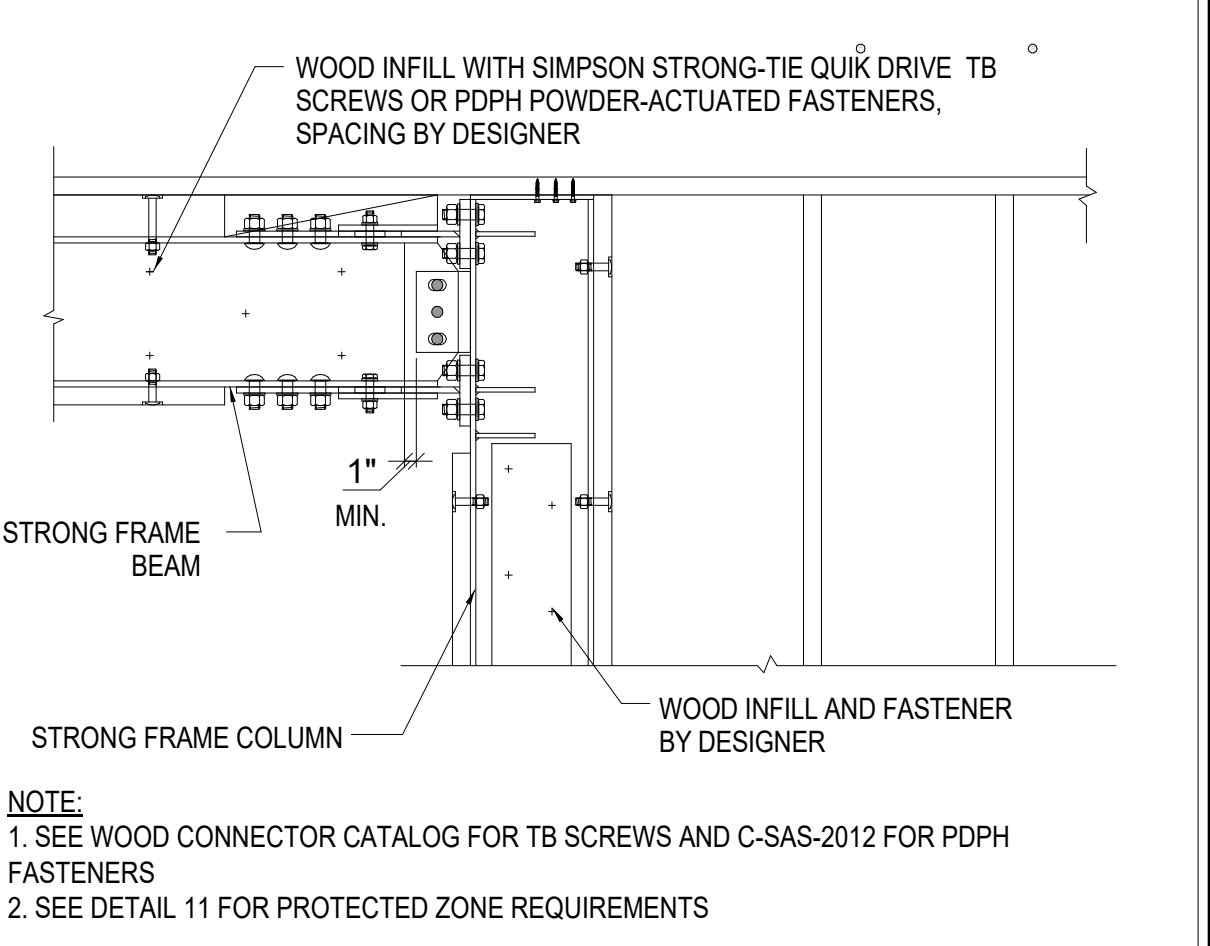

WOOD INFILLS 13

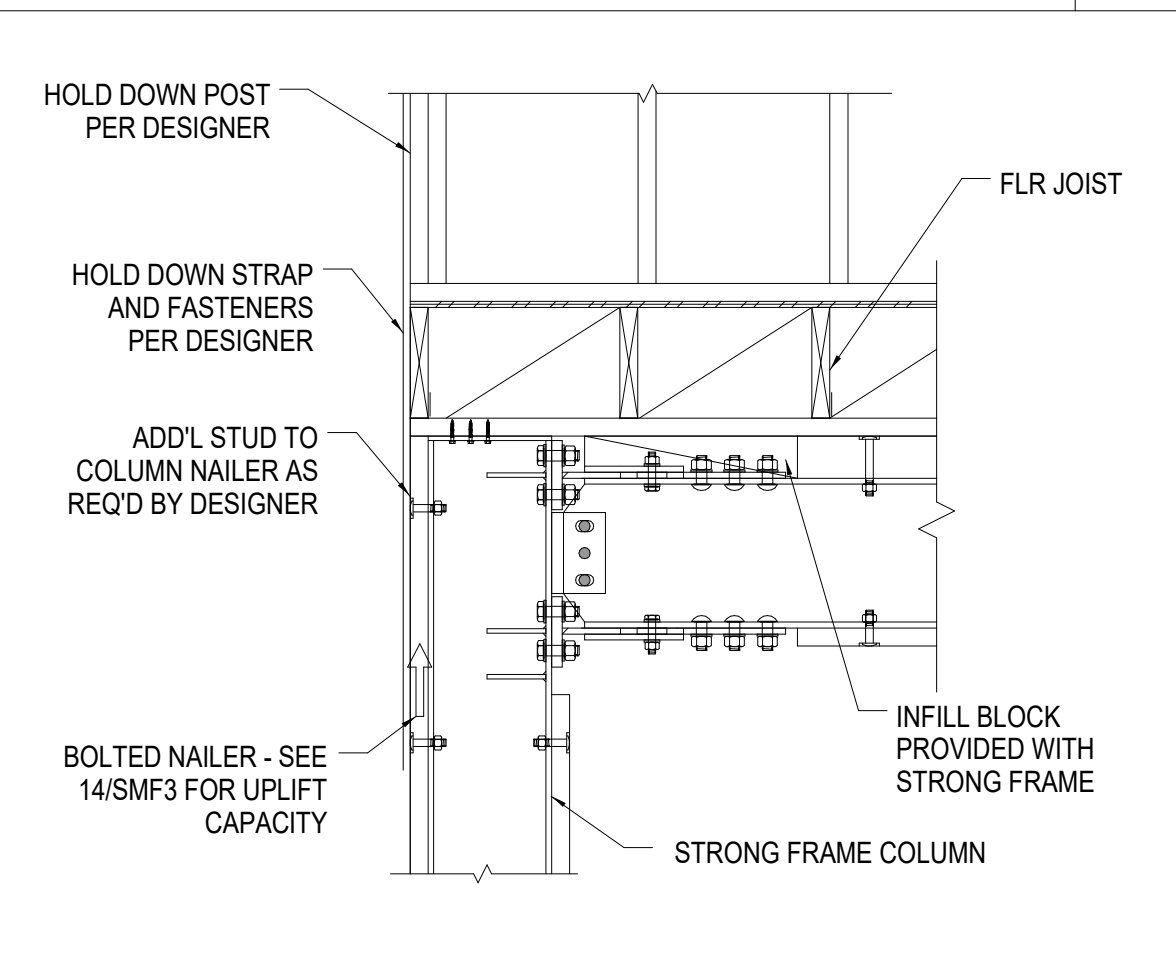

HOLDOWN POST TO SMF COL. 4

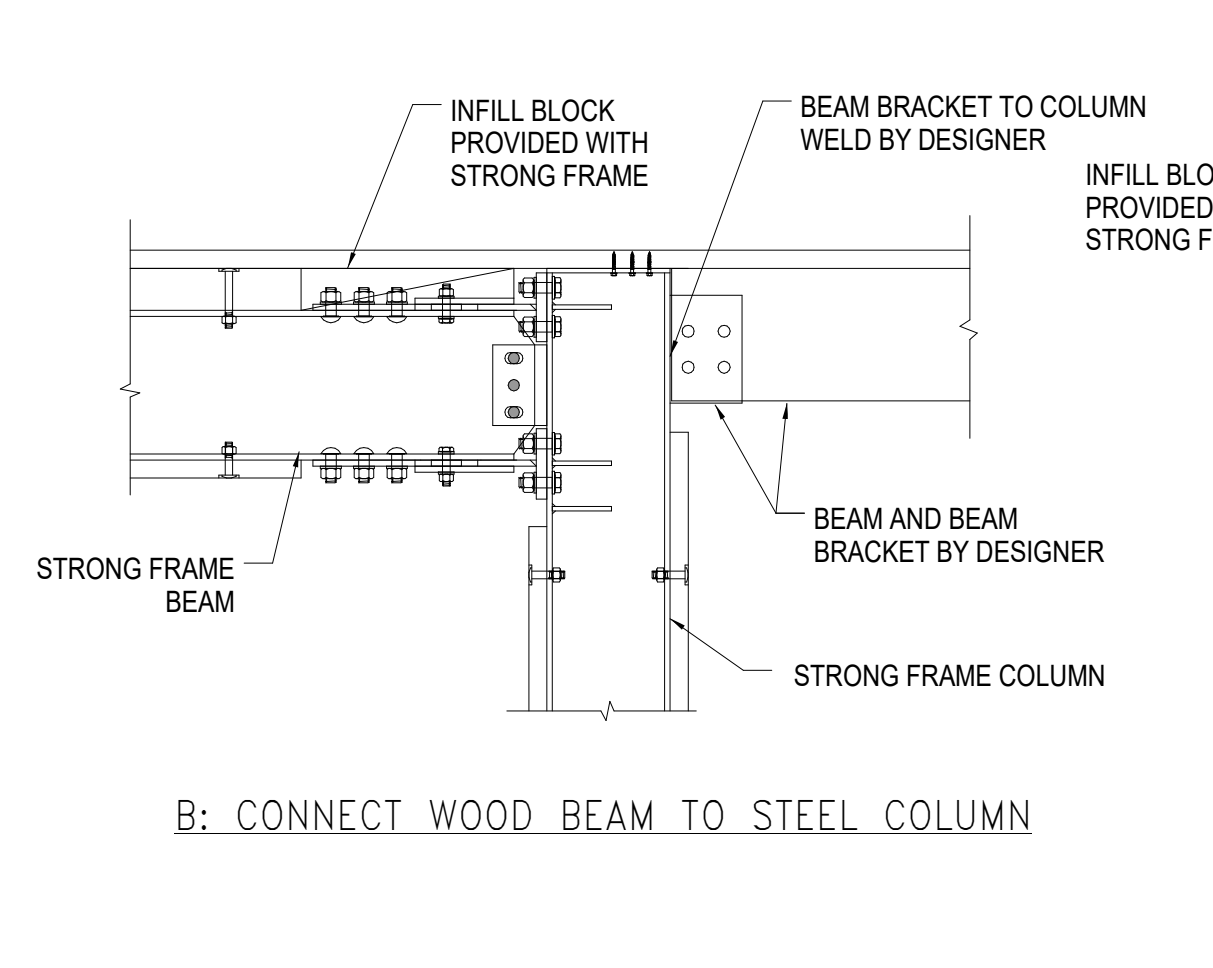

B: CONNECT WOOD BEAM TO STEEL COLUMN

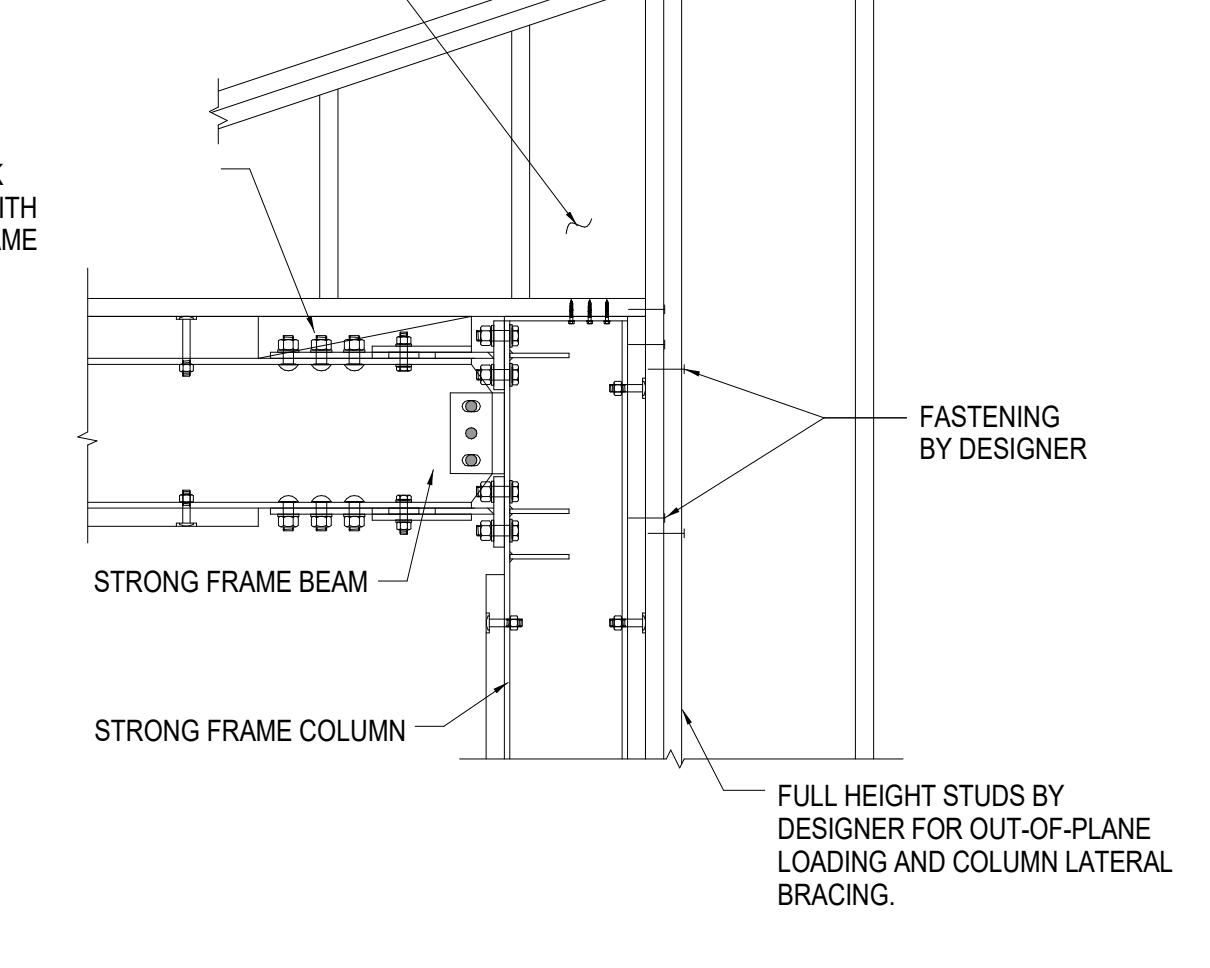

COLLECTOR DETAILS 7

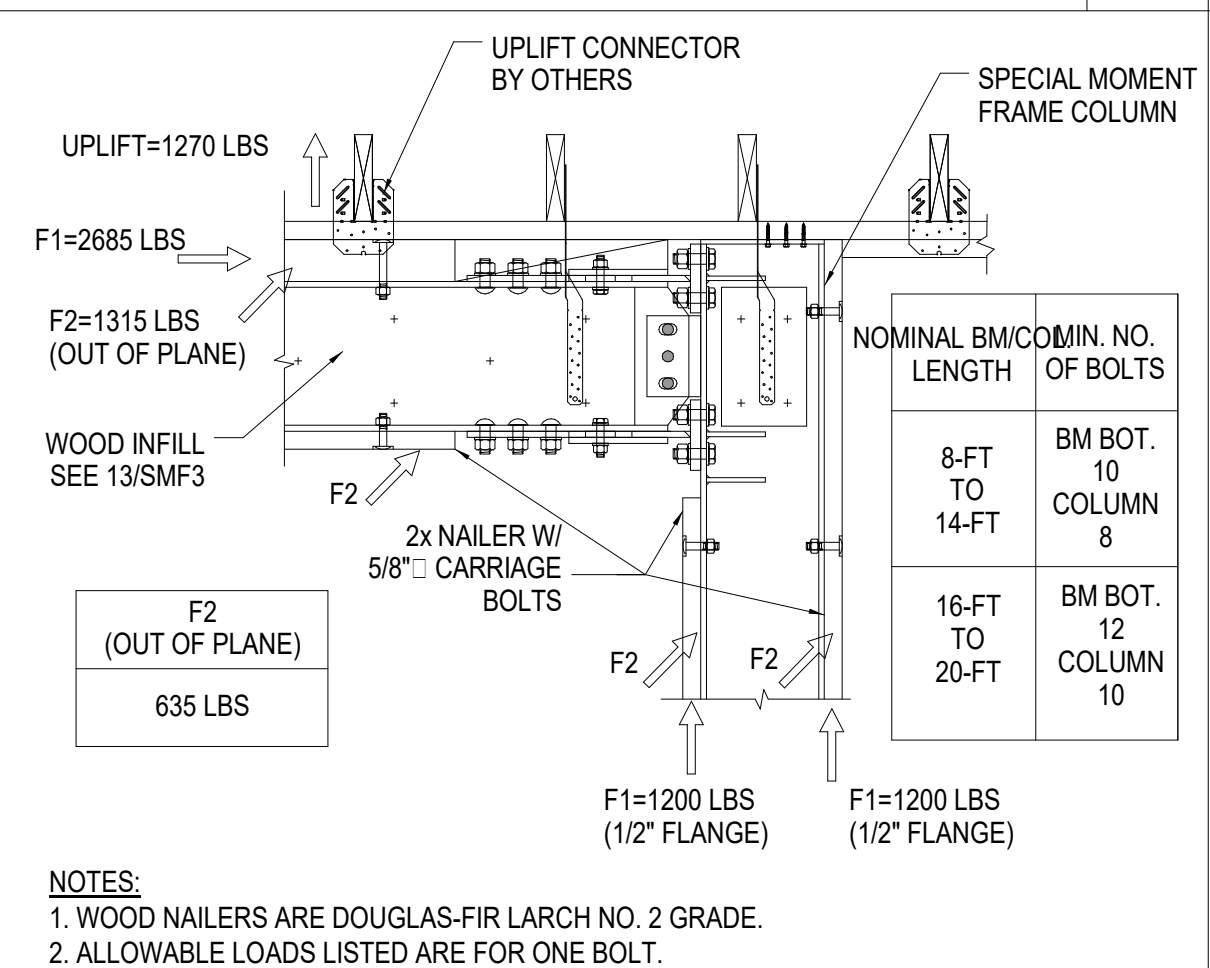

NAILER BOLT ALLOWABLE LOADS 14

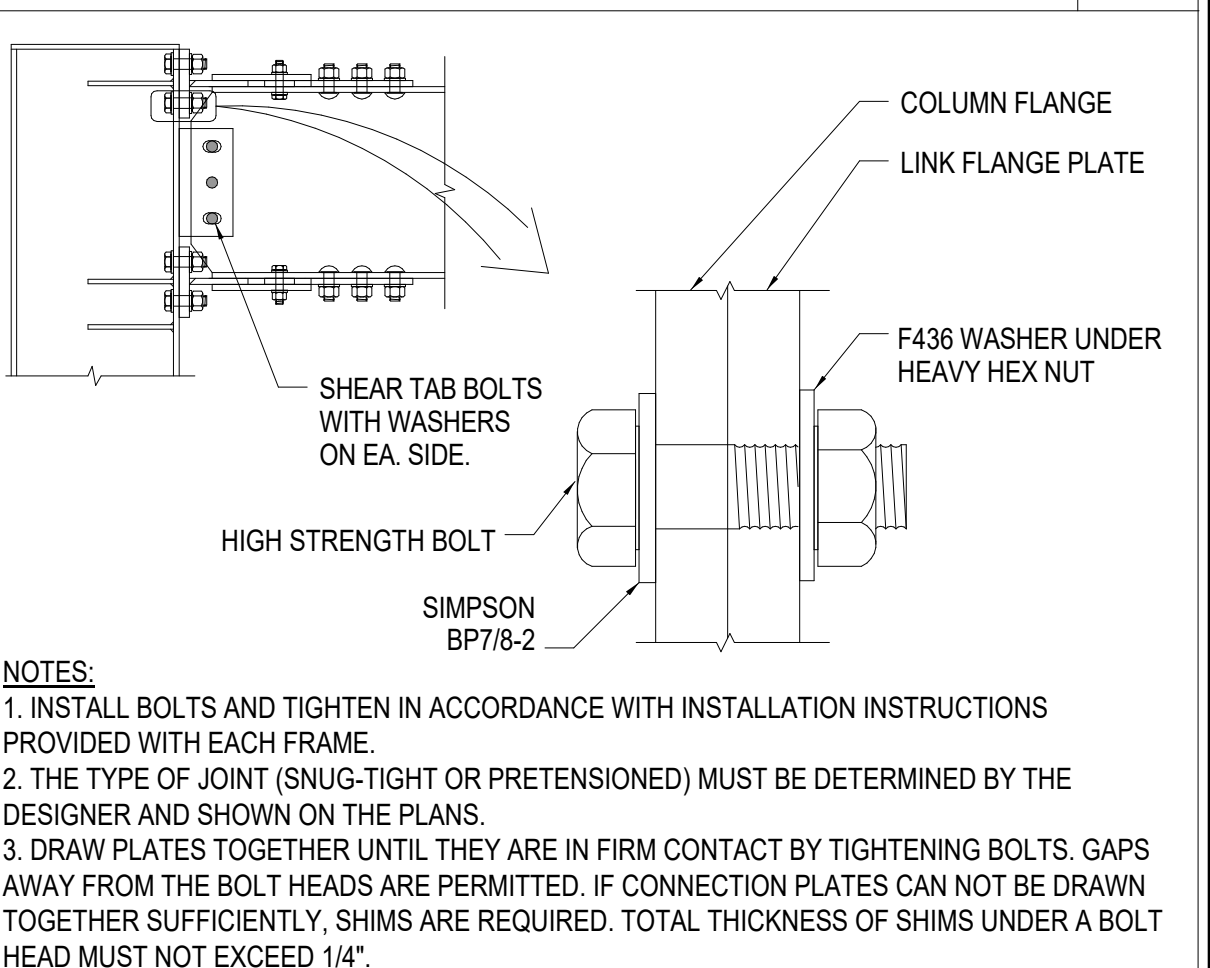

BEAM-TO-COLUMN CONNECTION 15

HOLDOWN POST TO SMF COL. 4

COLLECTOR DETAILS 7

RAKE WALL DETAILS 10

NAILER BOLT ALLOWABLE LOADS 14

BEAM-TO-COLUMN CONNECTION 15

CT ENGINEERING INC.
 Structural Engineers
 180 Nickerson Street, Suite 302, Seattle, WA 98109
 206.285.4572 (V) 206.285.0618 (F)
 www.ctengineering.com

SEAL
 STATE OF WASHINGTON
 REGISTERED PROFESSIONAL ENGINEER
 No. 12162
 DATE: 03/25/22

JOB #: 21162
 ENG: Designer
 CAD: Author
 SCALE: As indicated
 KEY ISSUE DATES:
 IS: SD
 CS: CD
 PERMIT: 03/25/2022
 OTHER: BD

Moment Frame Details
 PIPER REMODEL
 8429 SE 33RD PLACE
 MERCER ISLAND, WA 98040

S8.2

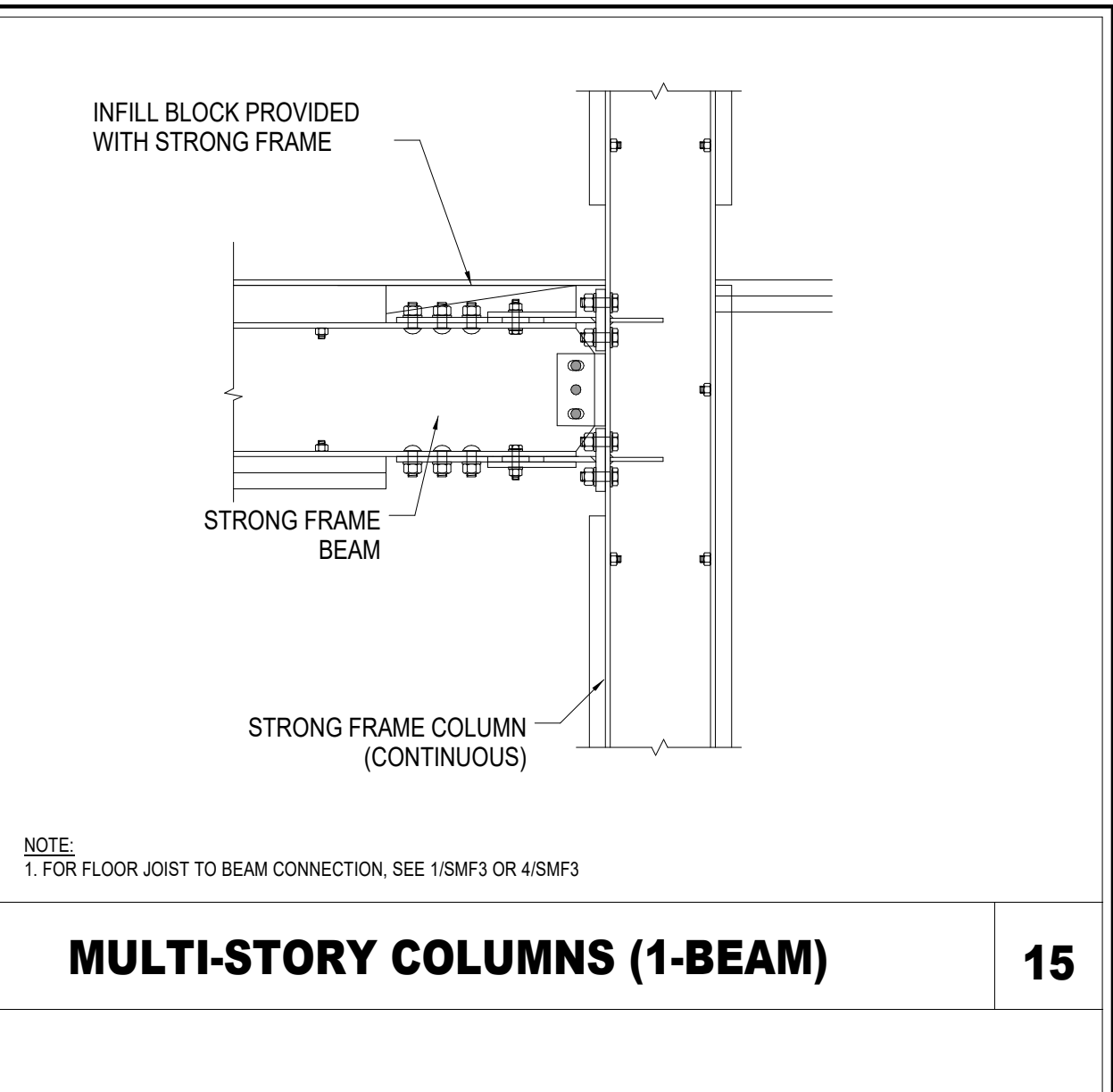
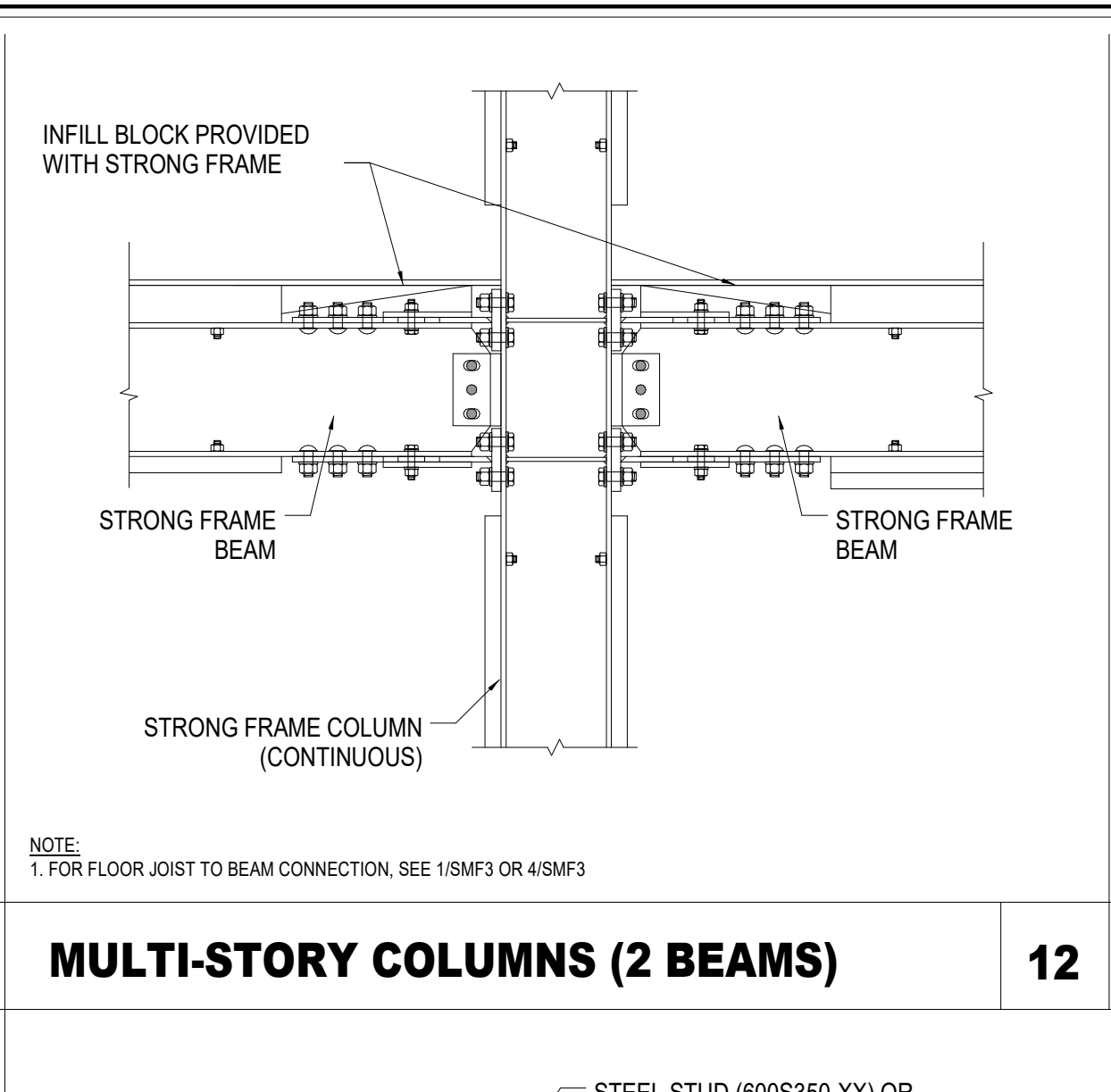
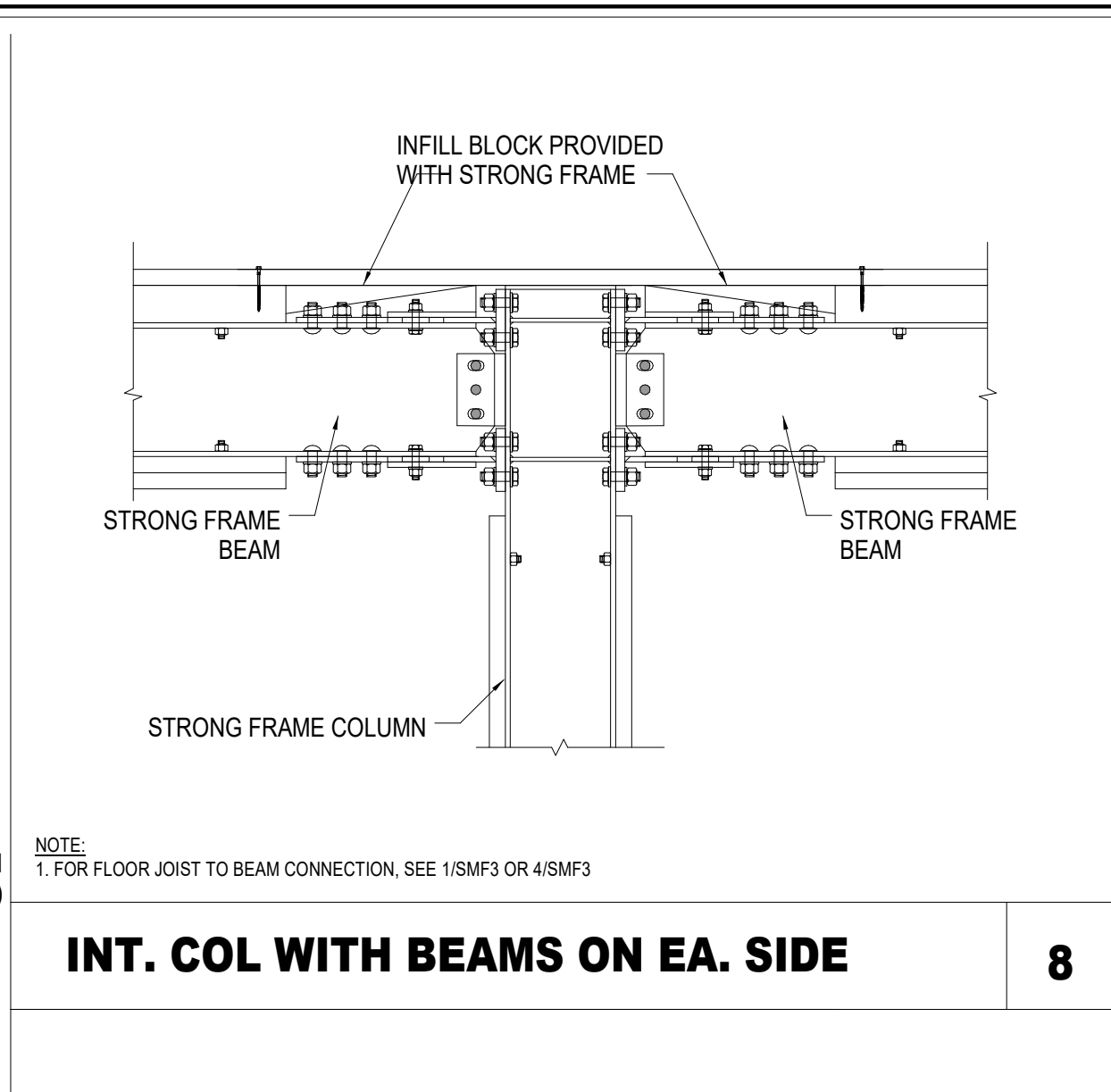
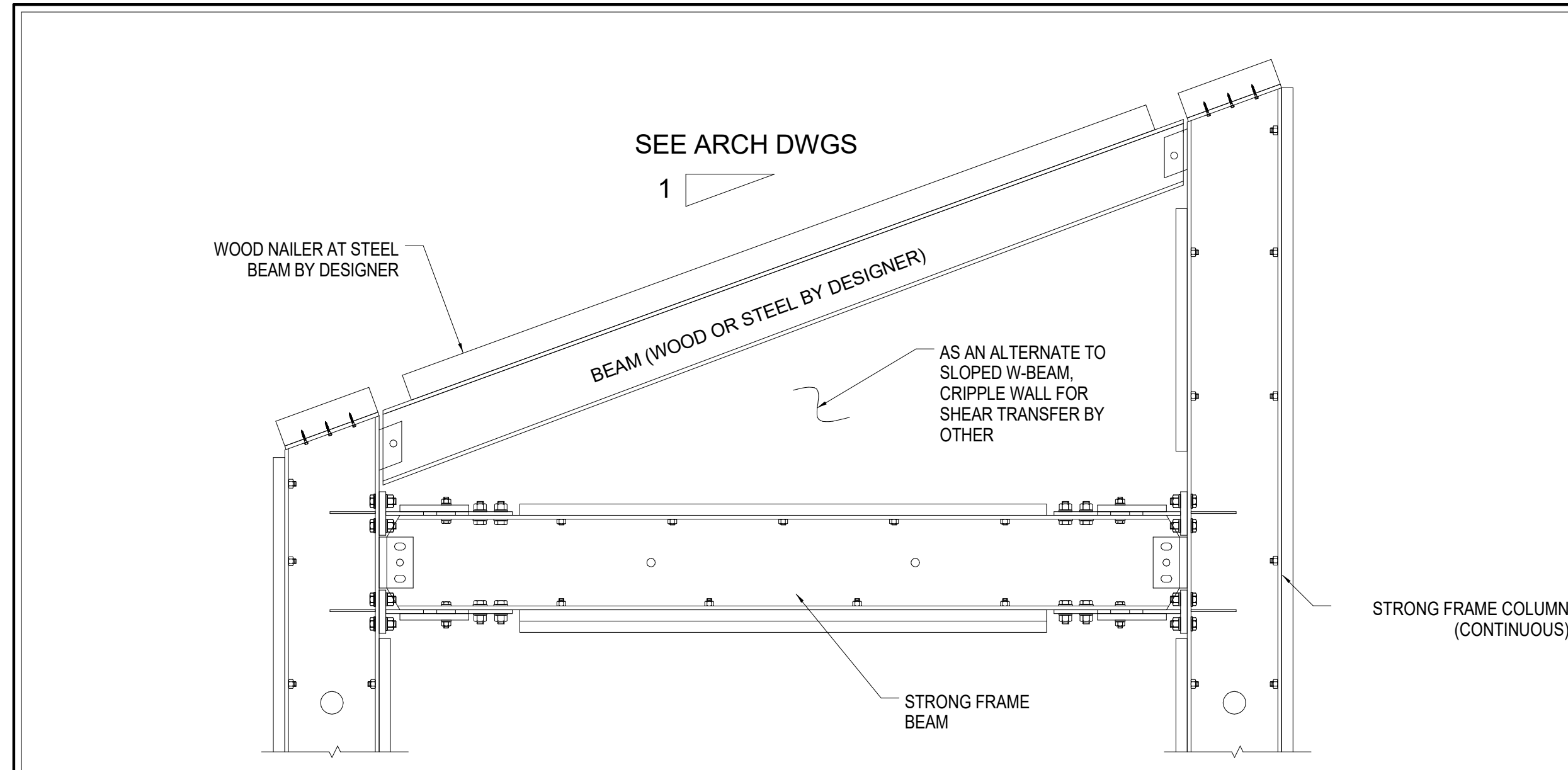

SST SMF WITH SLOPED ROOF BEAM 1

INT. COL WITH BEAMS ON EA. SIDE 8

MULTI-STORY COLUMNS (2 BEAMS) 12

MULTI-STORY COLUMNS (1-BEAM) 15

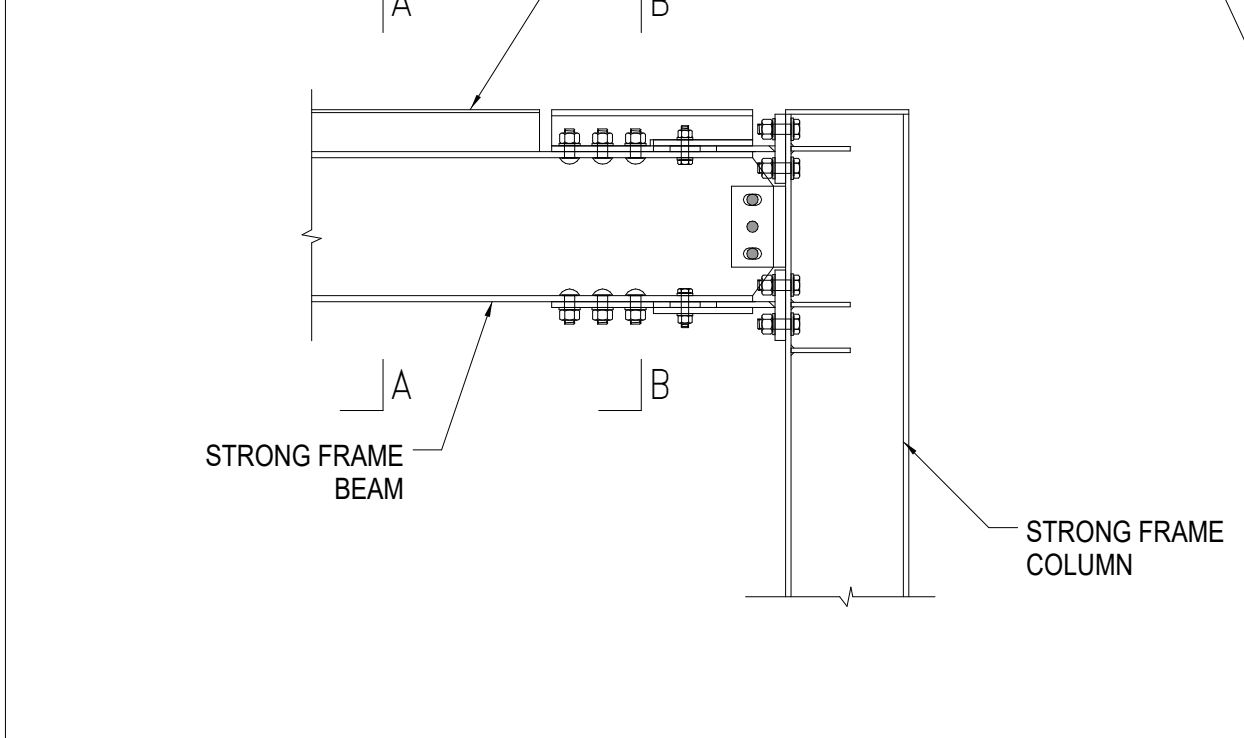
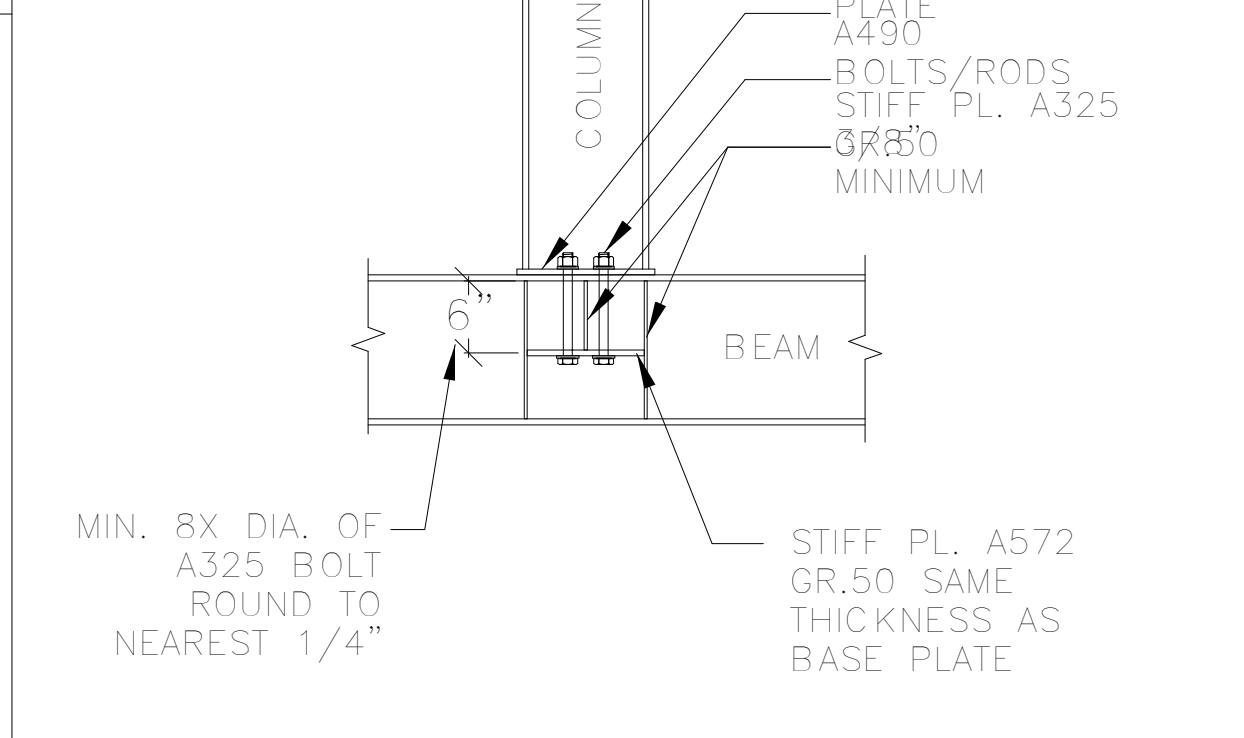
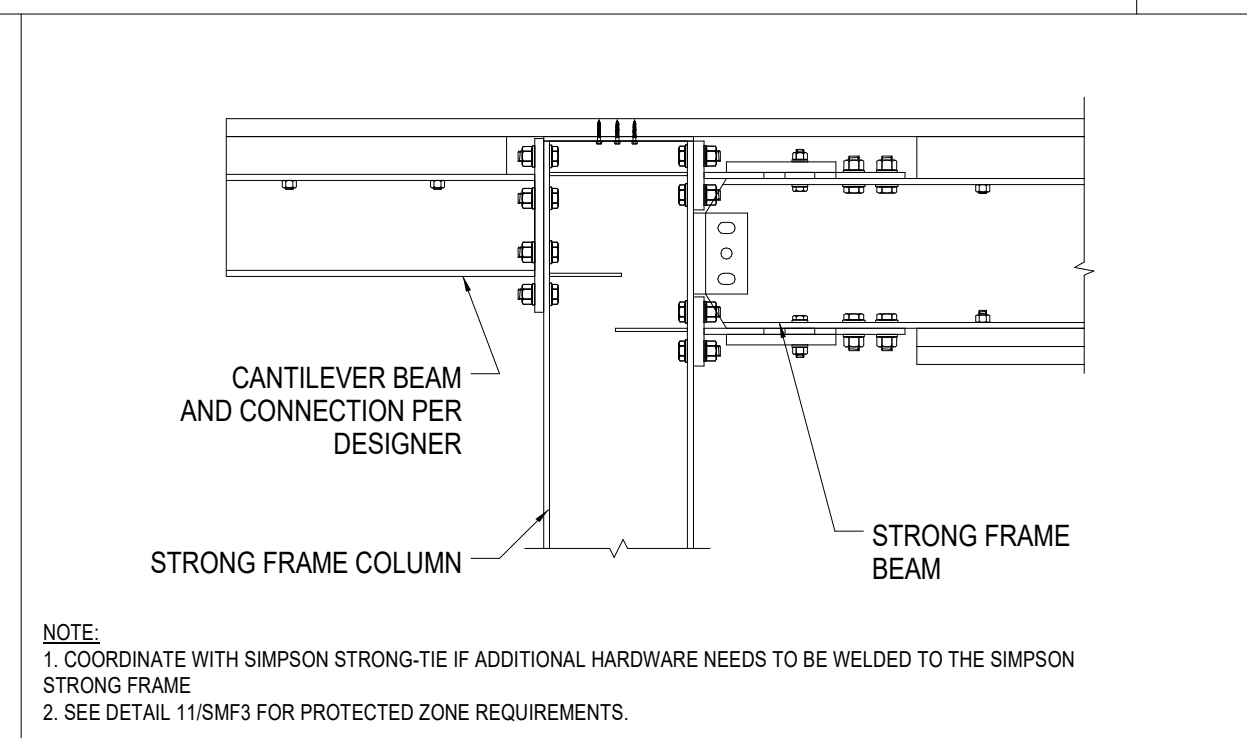
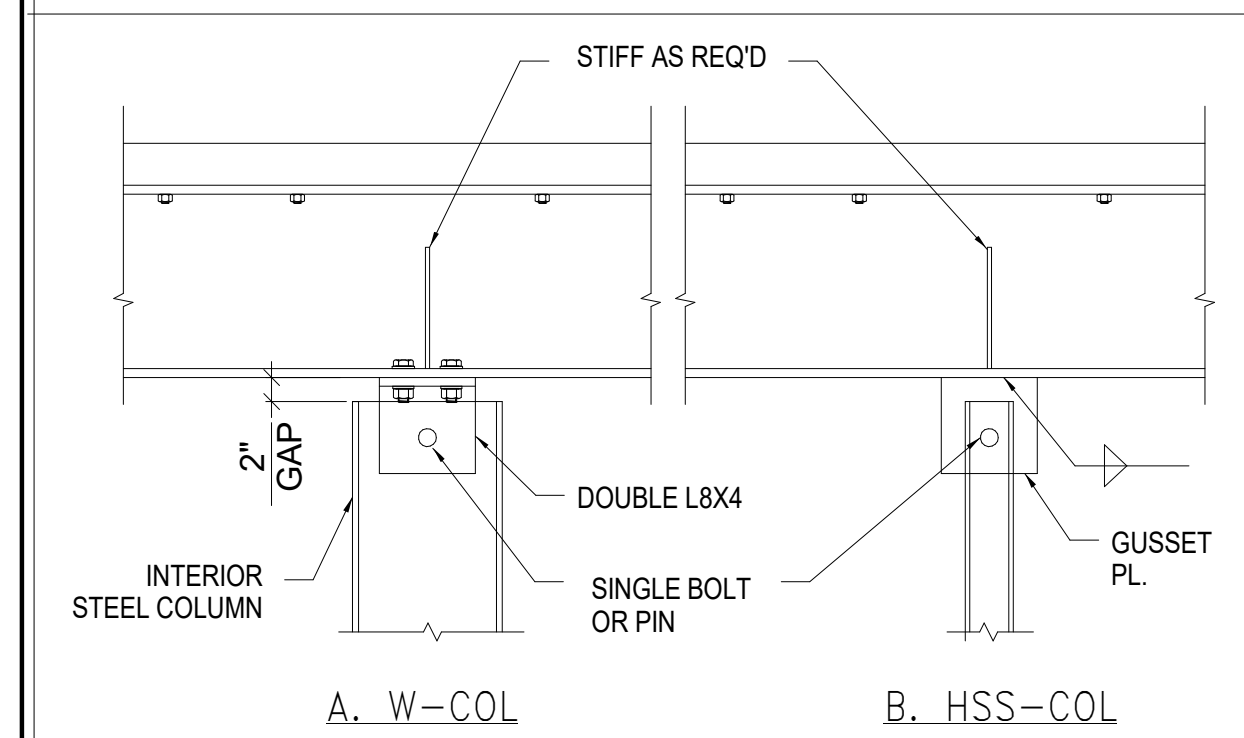

INTERIOR PINNED BEARING COL. 2

CANTILEVER BEAM TO COLUMN 5

SMF COLUMN ON STEEL BEAM 9

SMF BEAM ATTACHEMENT FOR COLD-FORMED STEEL CONSTRUCTION 16

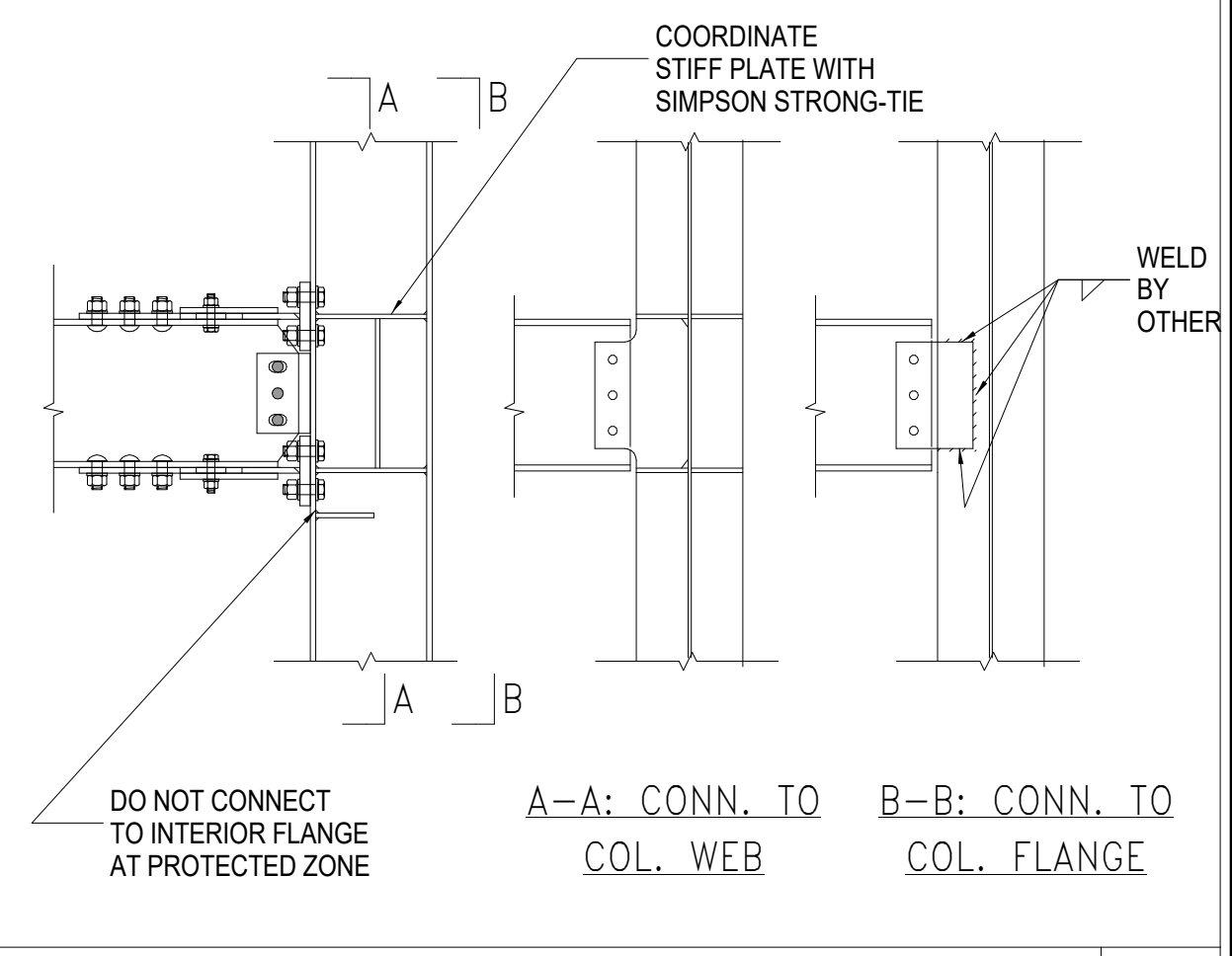
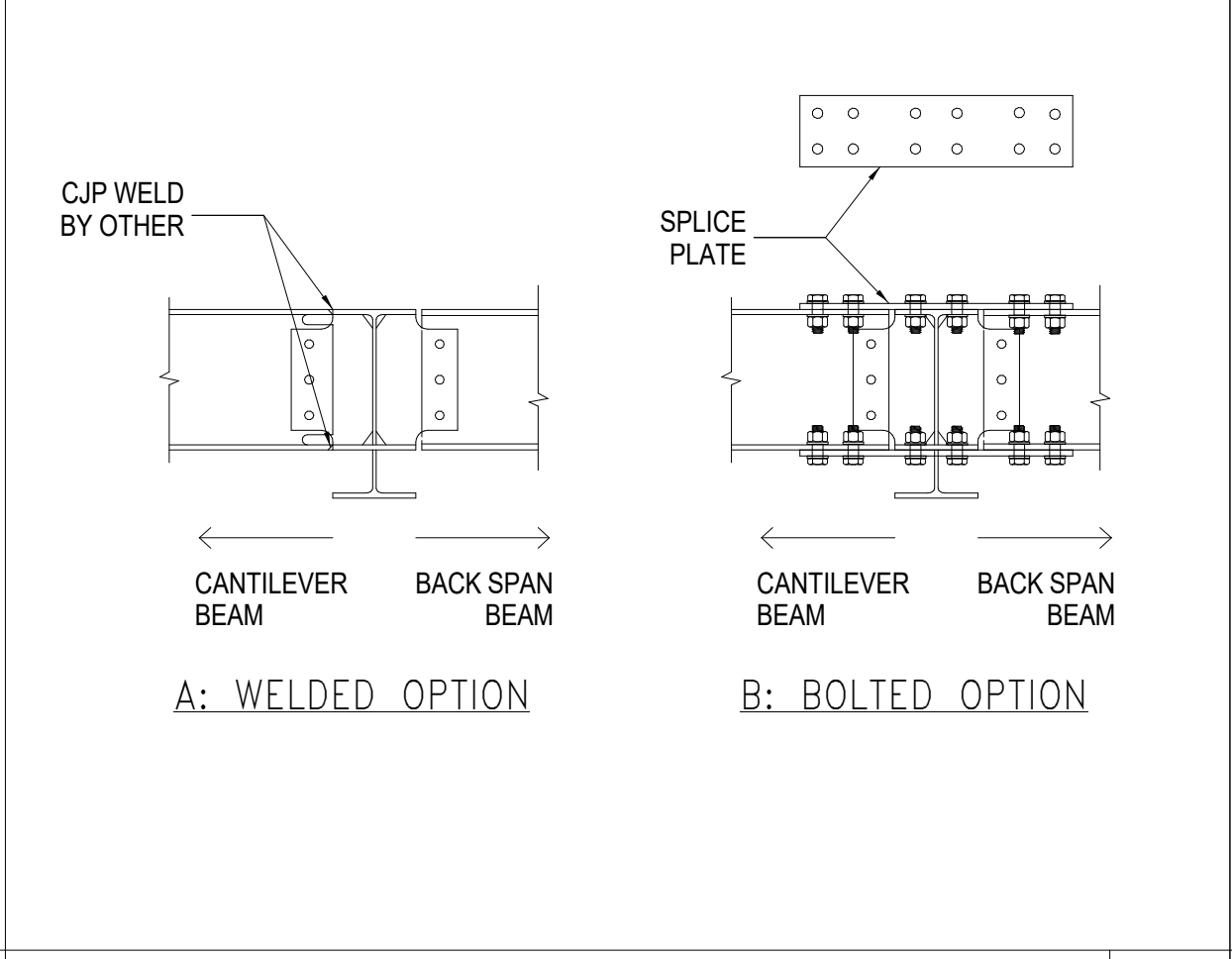
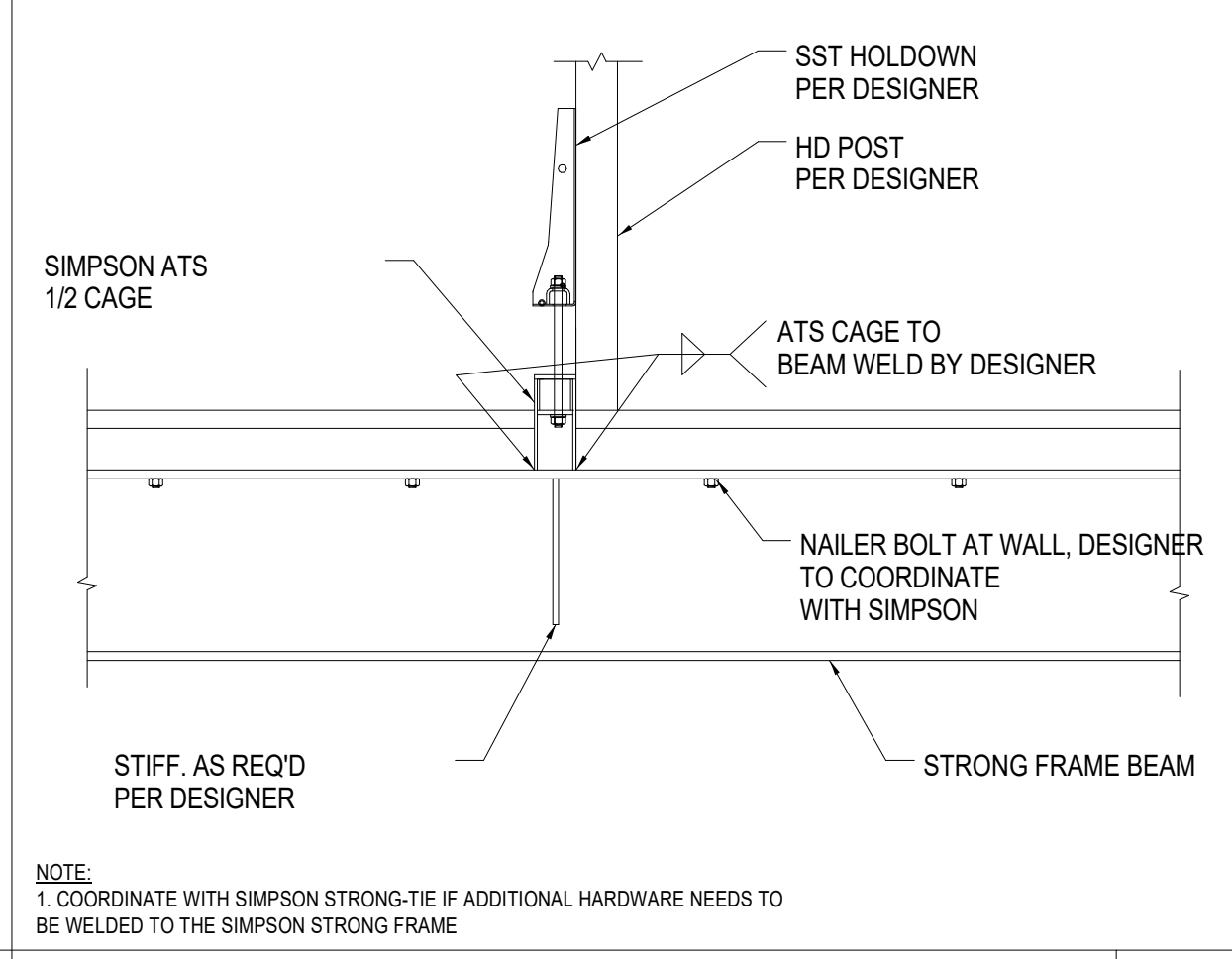
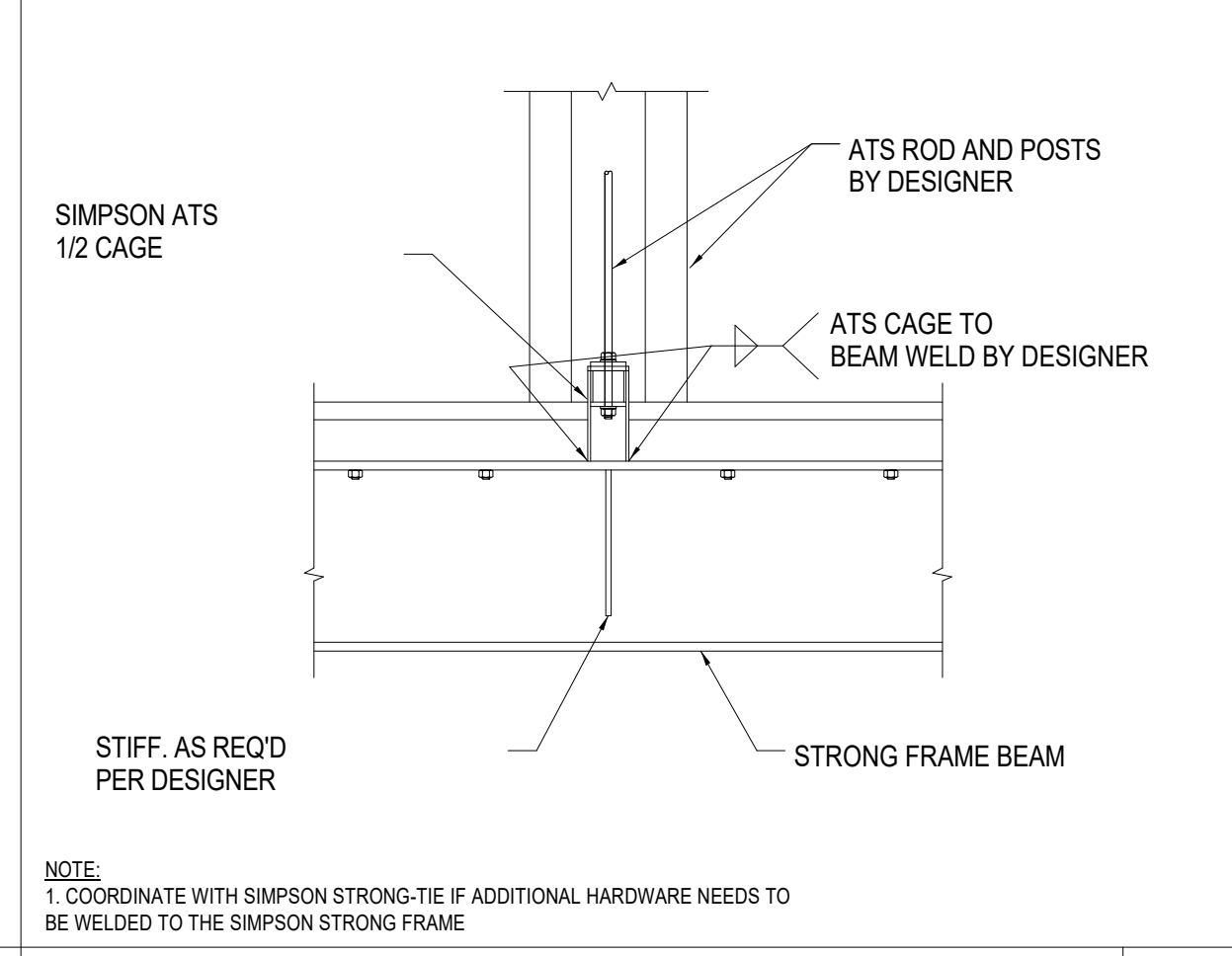
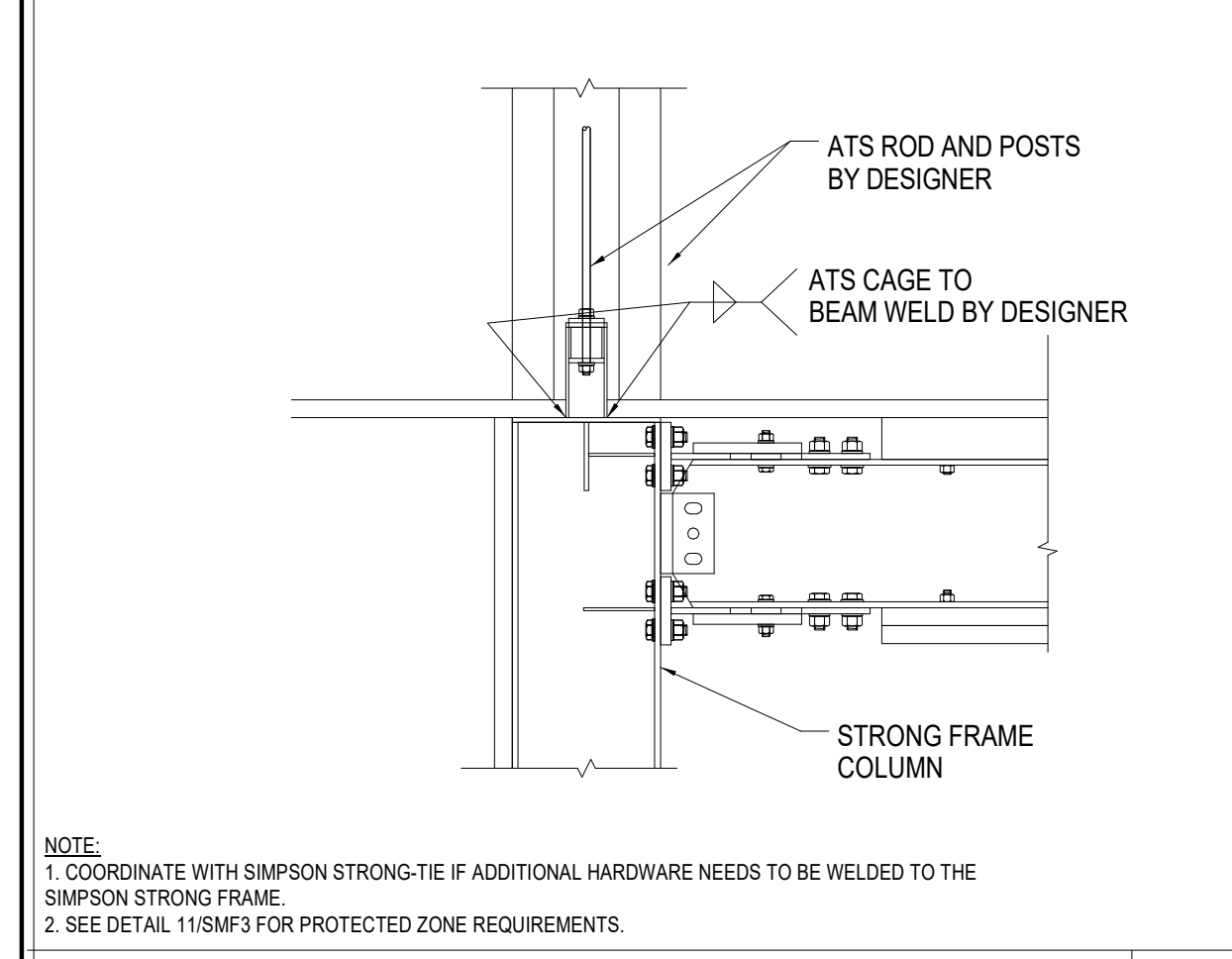

ATS ROD//HD ON STEEL COLUMN 3

ATS ROD ON STEEL BEAM 6

SHEAR WALL HD ON STEEL BEAM 10

CANTILEVER STEEL BEAM CON. 13

BEAM CONNECTION TO COLUMN 17

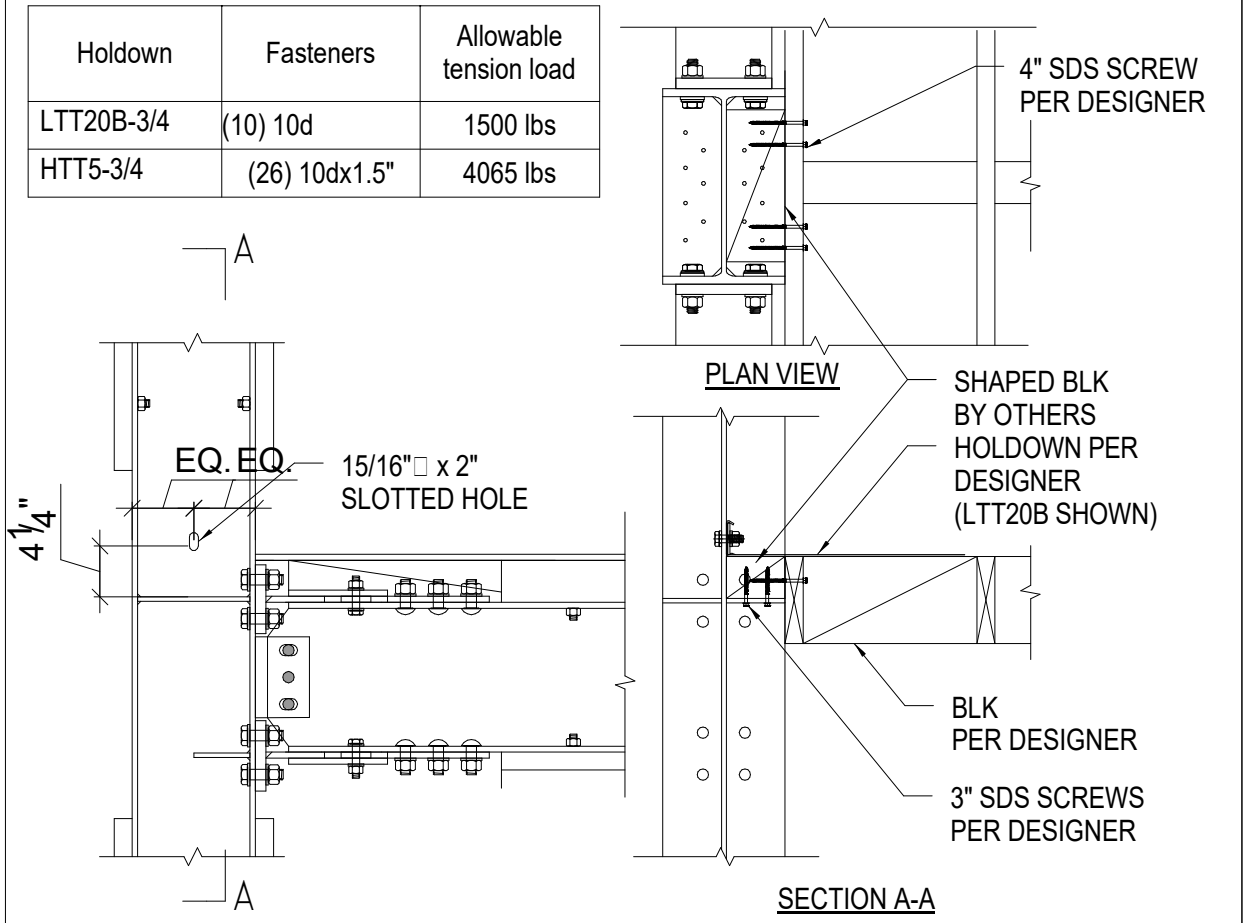
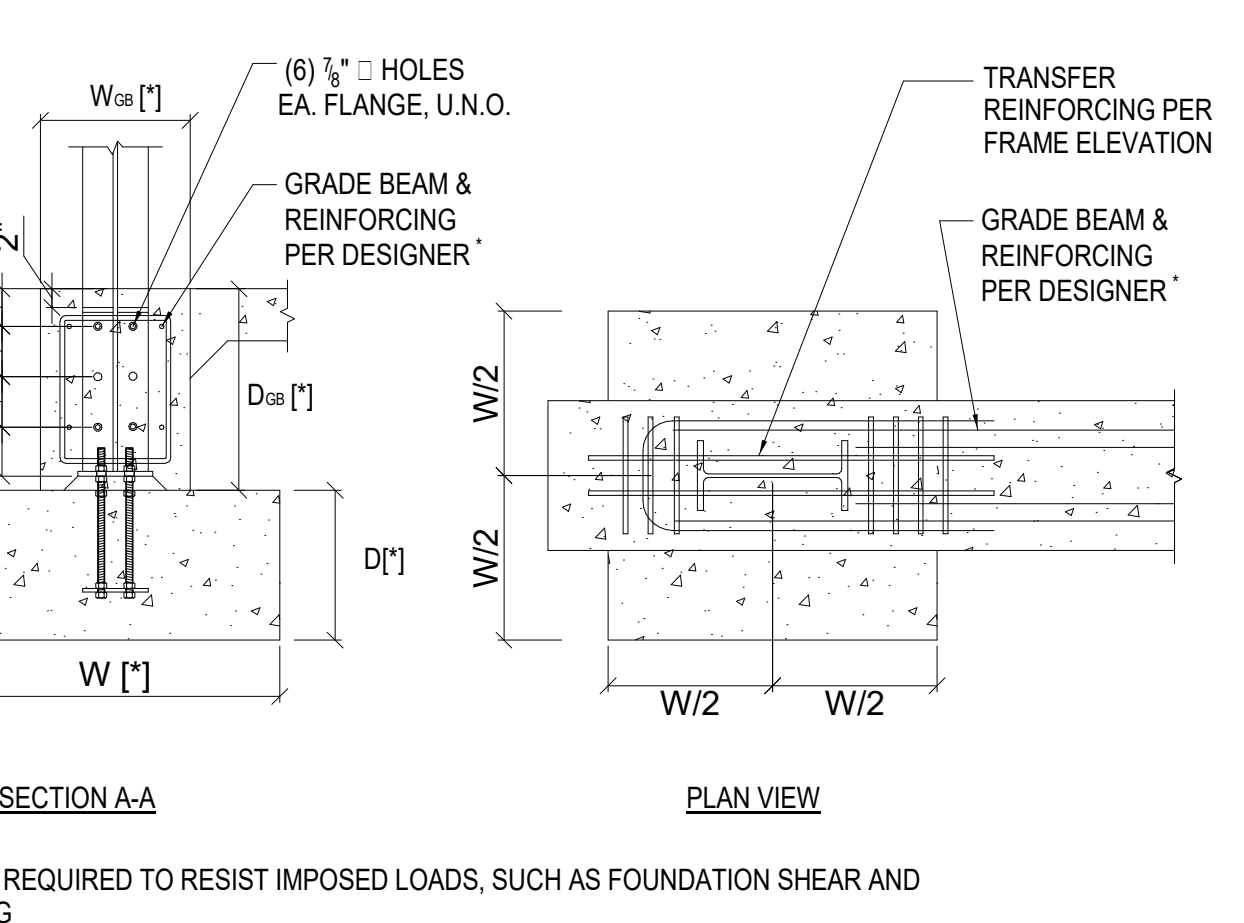
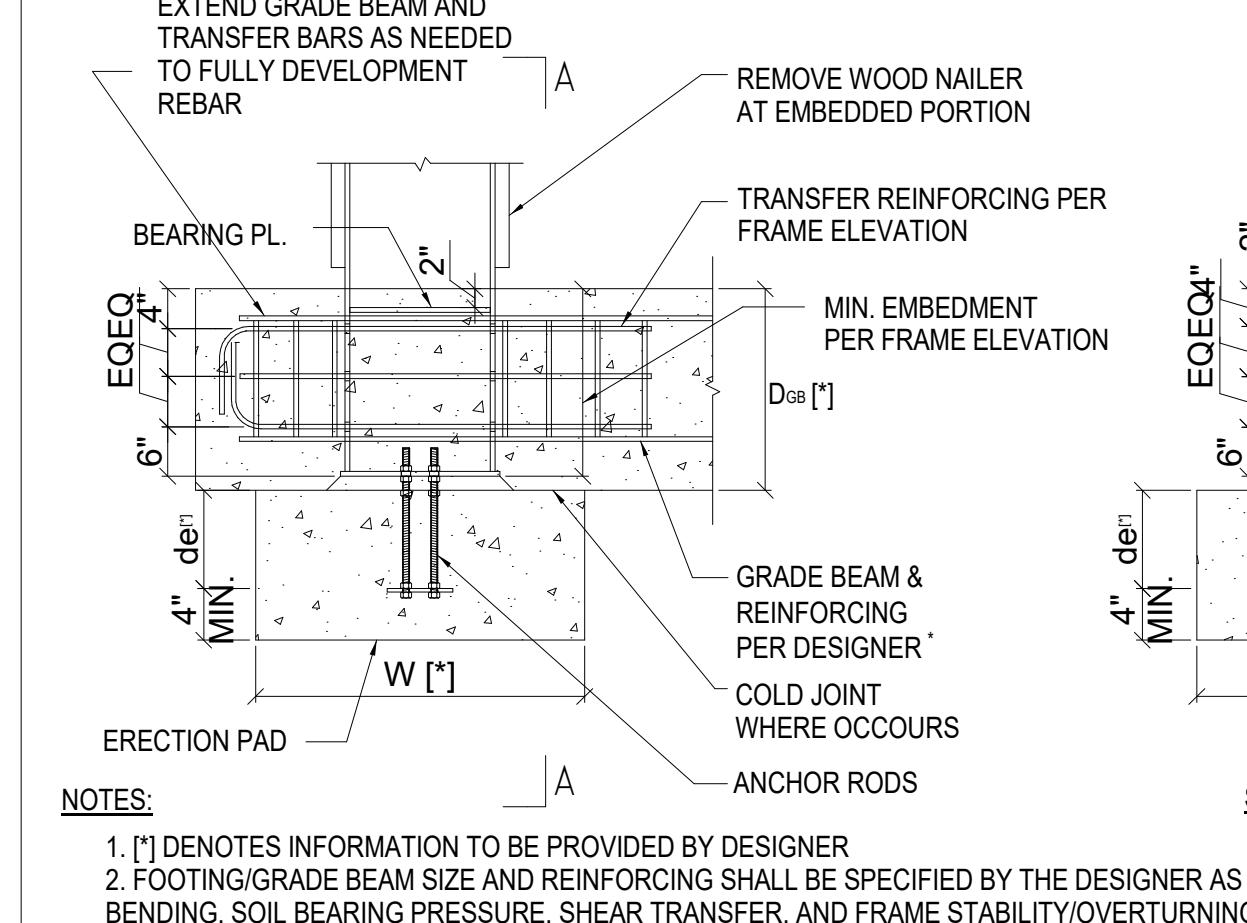
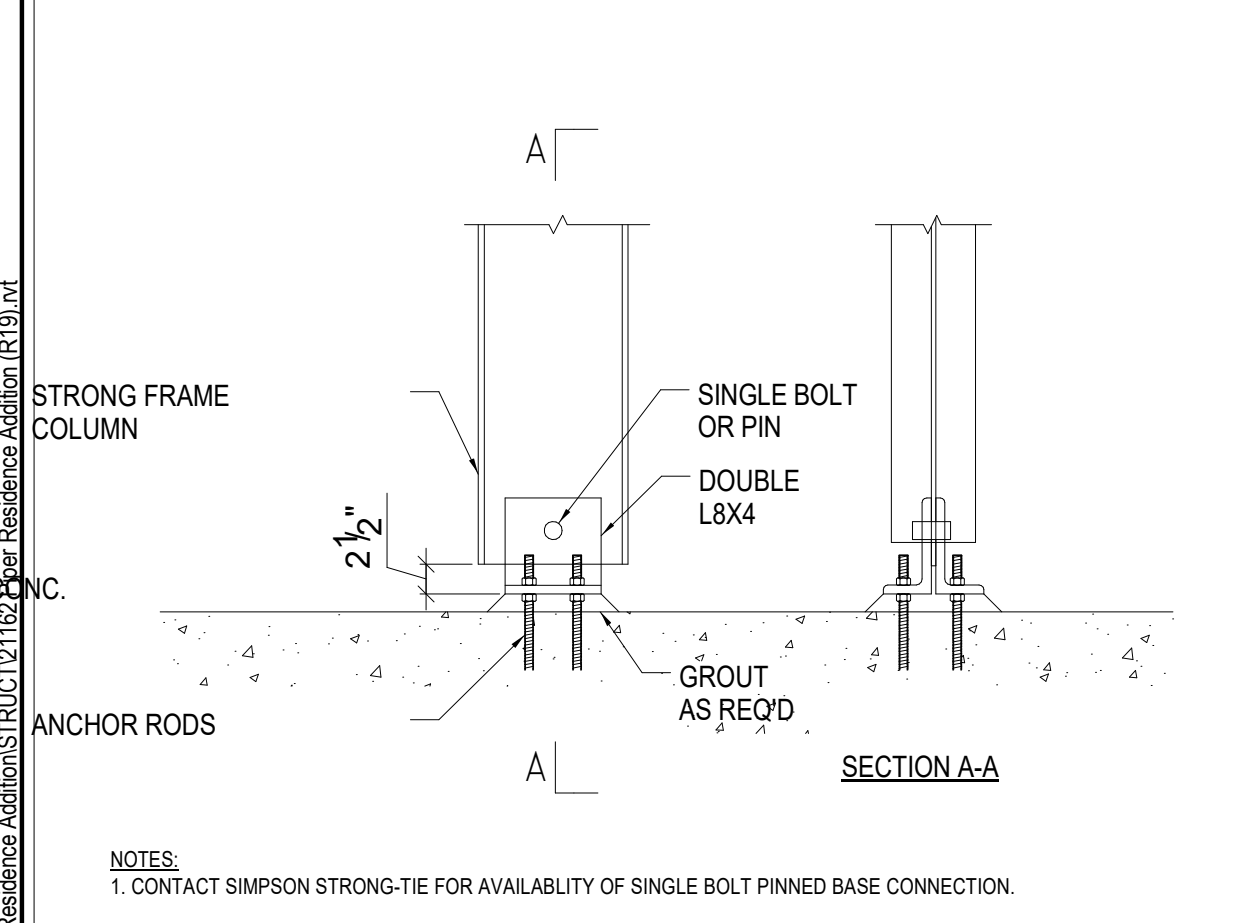

SINGLE BOLT PINNED BASE DETAIL 4

FIXED BASE CONNECTION 11

COL. BRACING AT FLOOR LEVEL 14

BOLTED COLUMN SPLICE 18

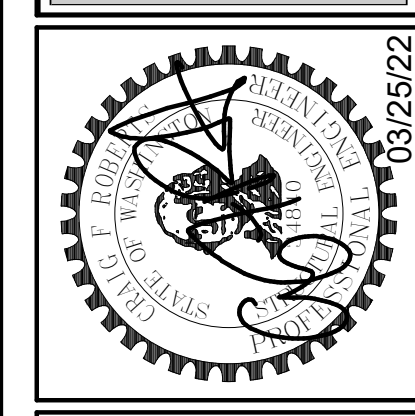

No.	REVISION	DATE

JOB #:	21162
ENG.:	Designer
CAD:	Author
SCALE:	3/4" = 1'-0"
KEY ISSUE DATES:	
	SD
	BD
	CD
	DD
	PERMIT: 03.25.2022
	OTHER: BD

9/25/2022 4:28:16 PM
 N:\21162 PIPER Remodel\Struct\118232-01-Residence Address\0318101.dwg

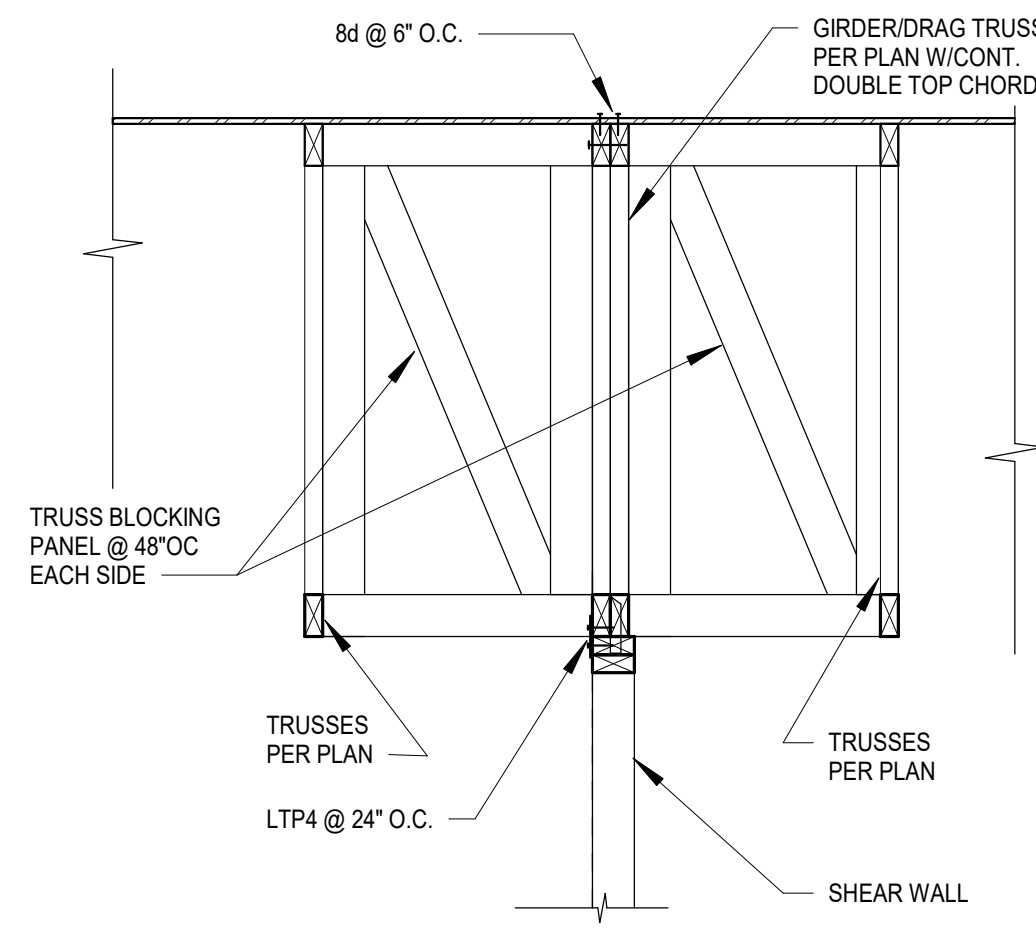

SCALE: 3/4" = 1'-0"
2 DRAG TRUSS TO WALL

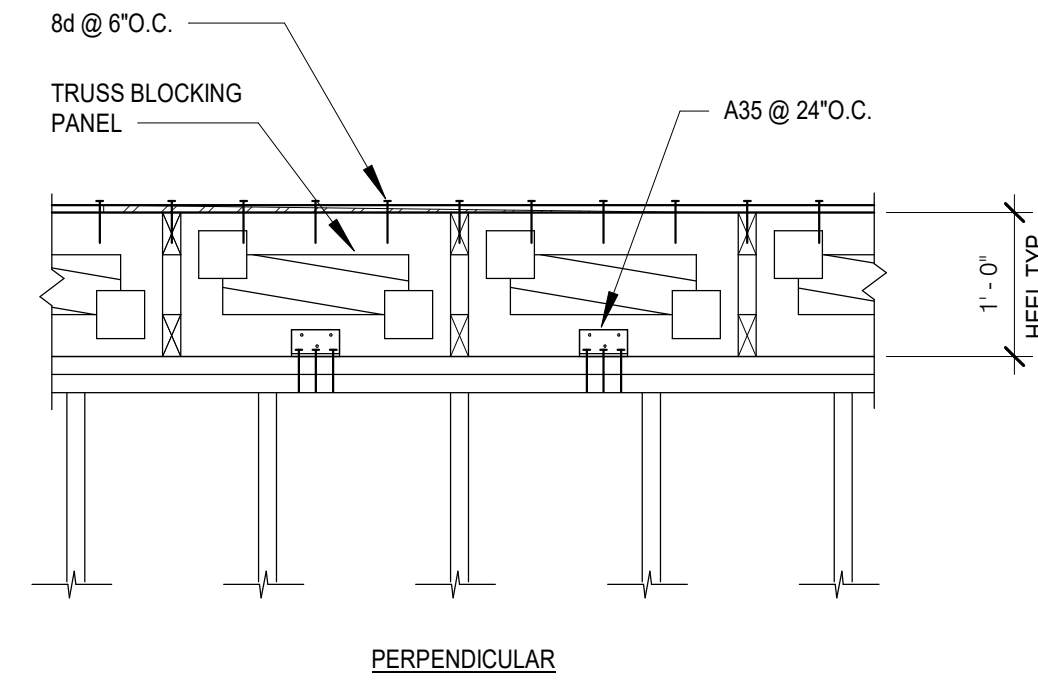

SCALE: 3/4" = 1'-0"
3 TYPICAL EXTERIOR WALL TO TRUSS

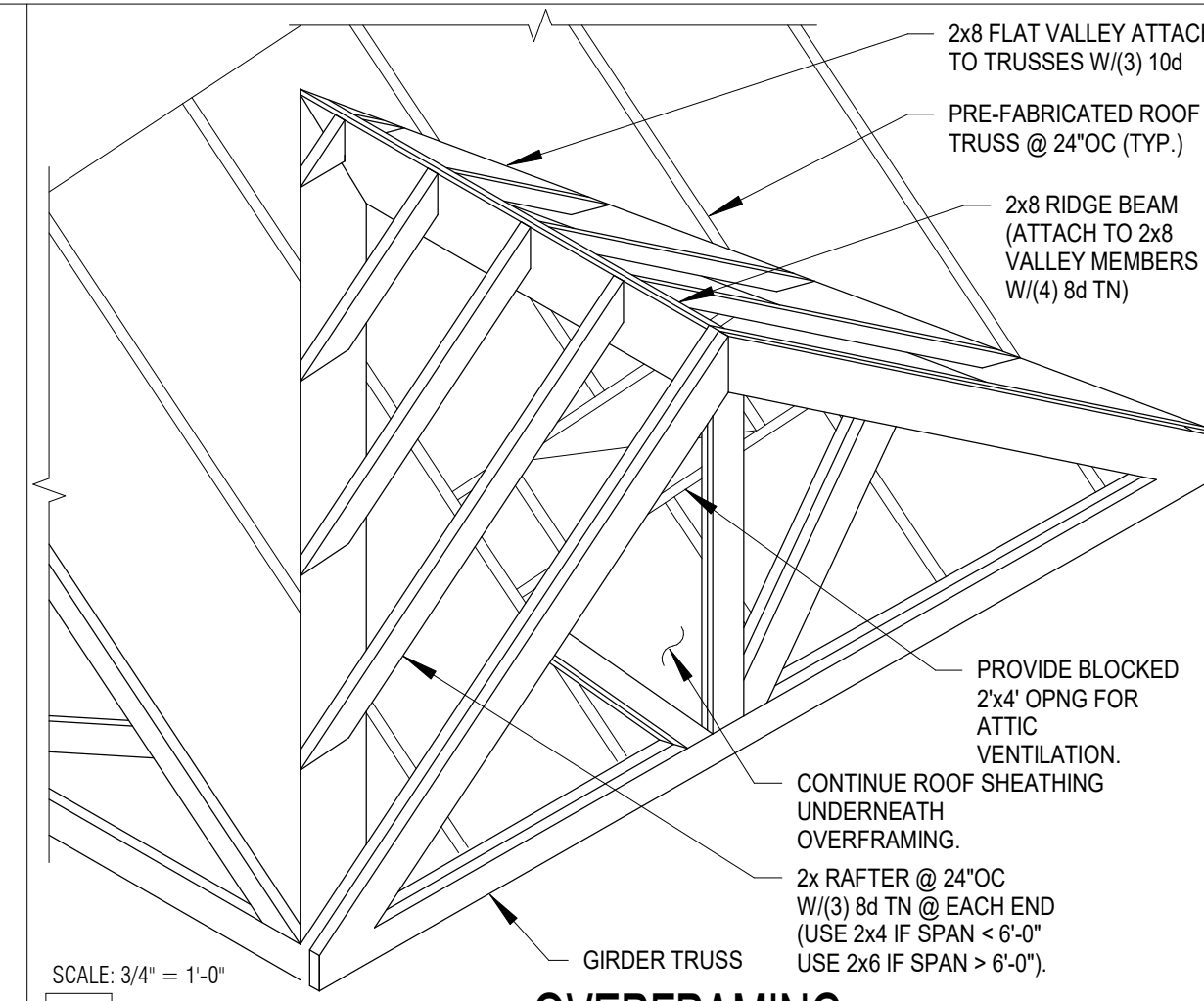

SCALE: 3/4" = 1'-0"
4 OVERFRAMING

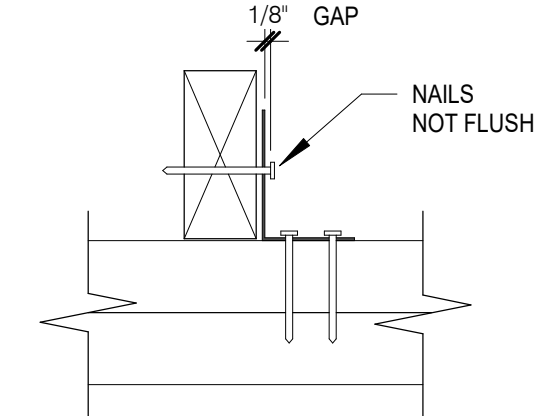
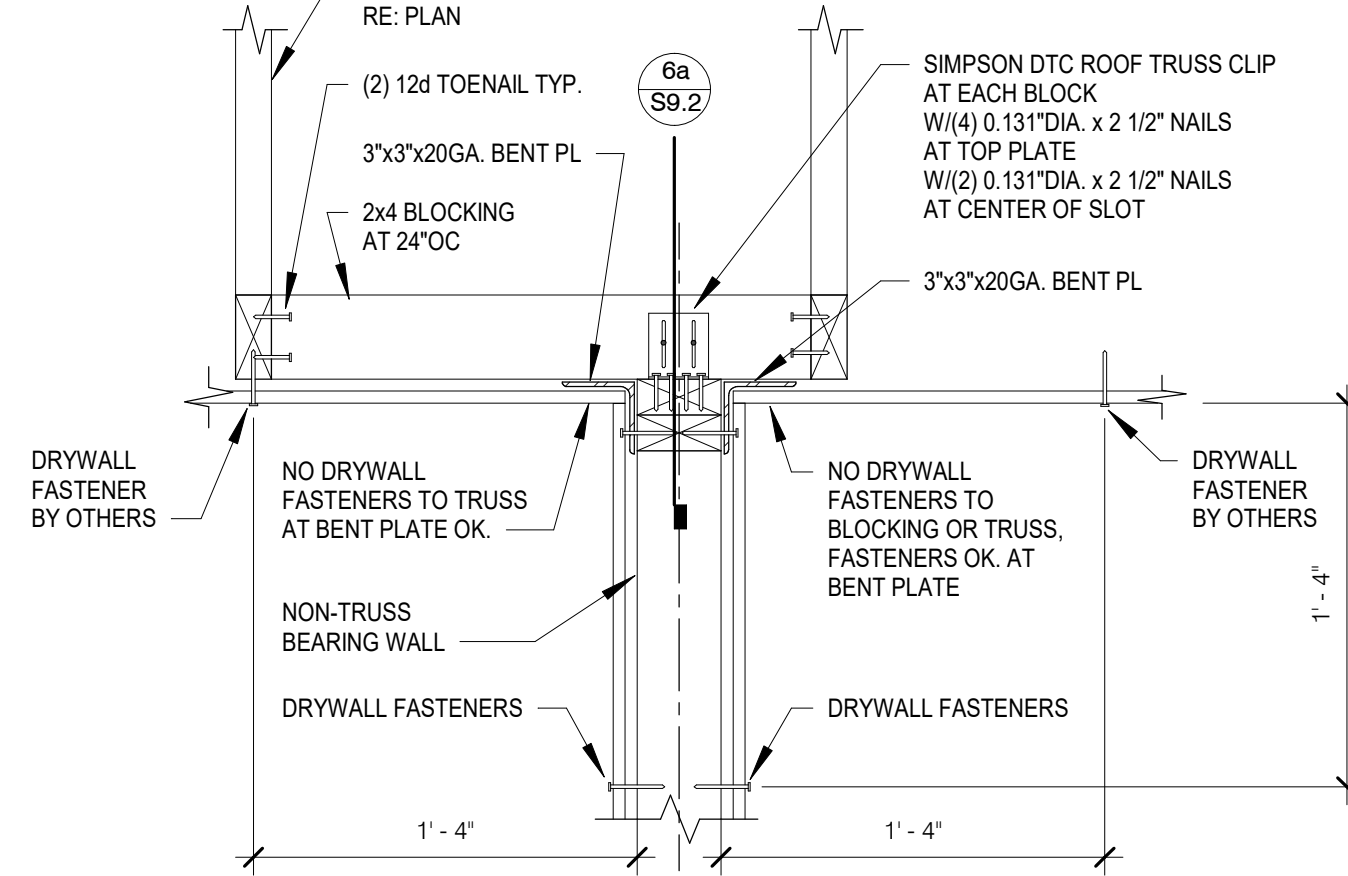
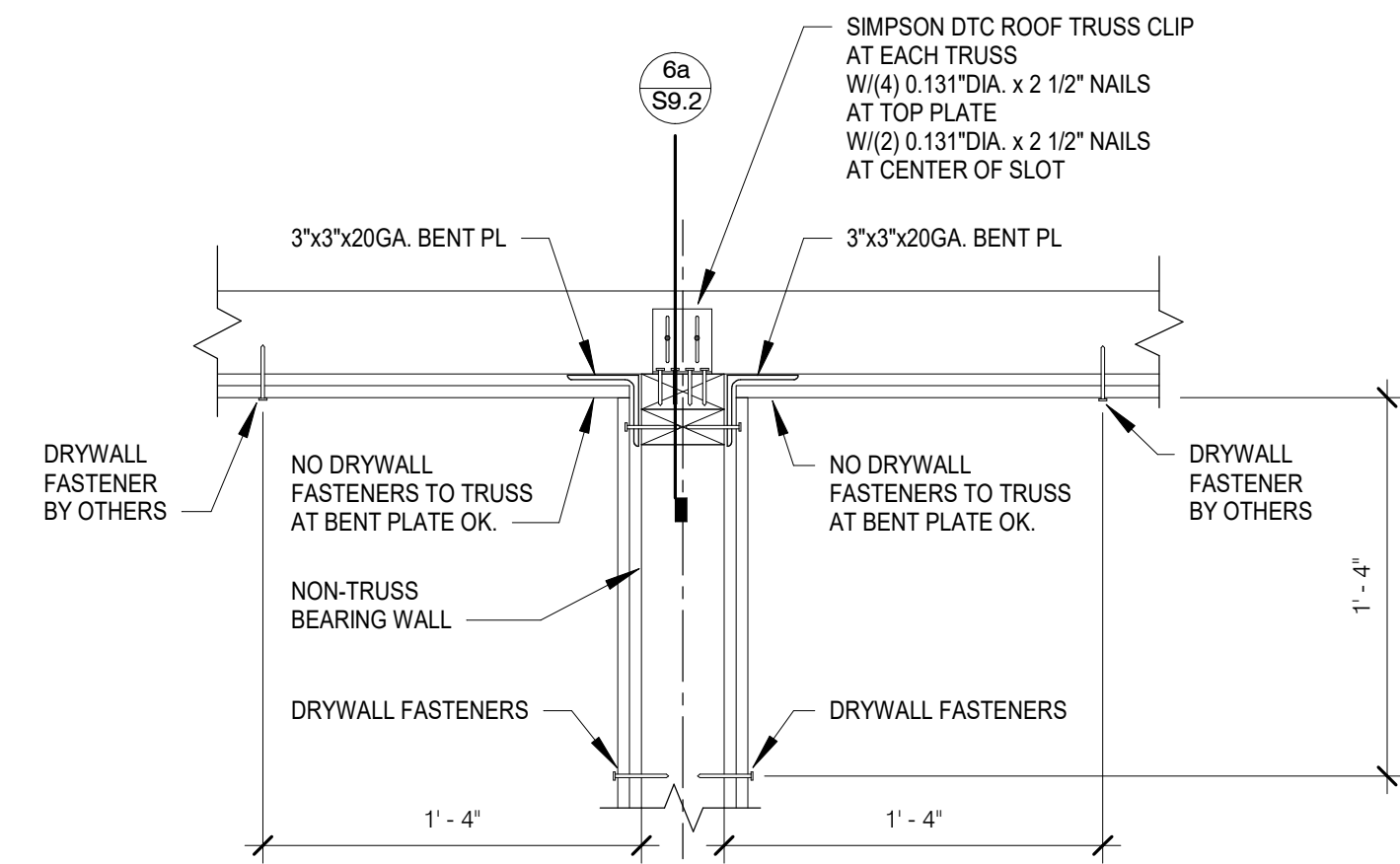

SCALE: 1 1/2" = 1'-0"
6 TYPICAL NON-BEARING WALL TO TRUSS

SCALE: 1 1/2" = 1'-0"
6 TYPICAL NON-BEARING WALL TO TRUSS

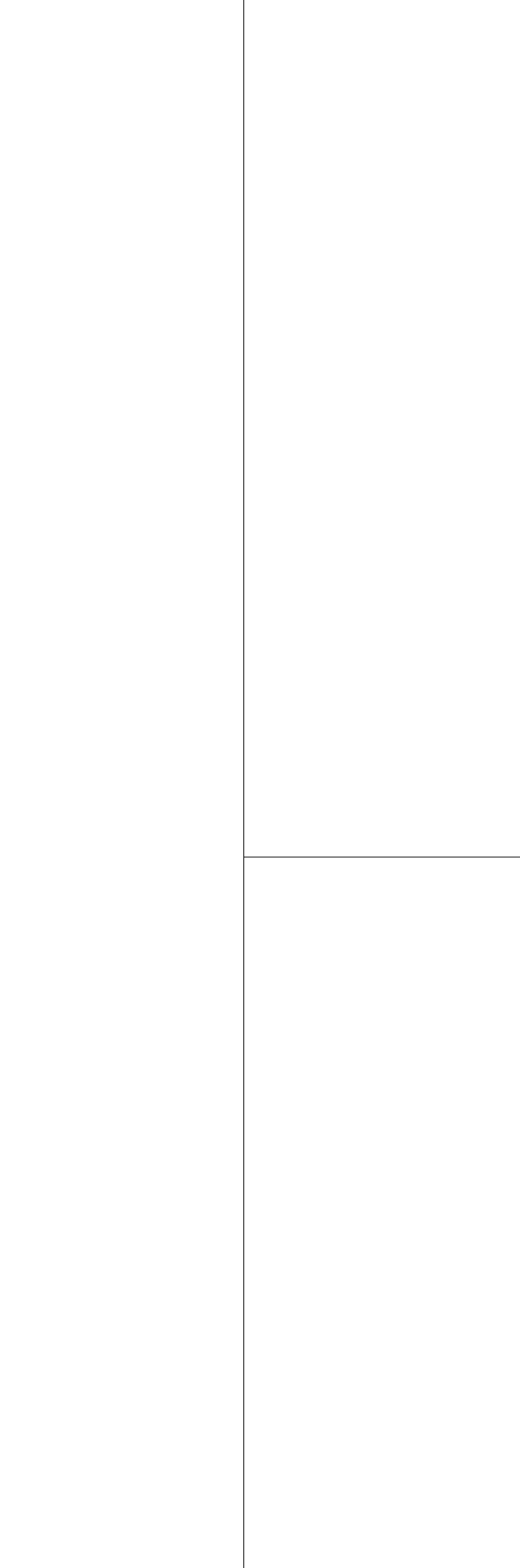
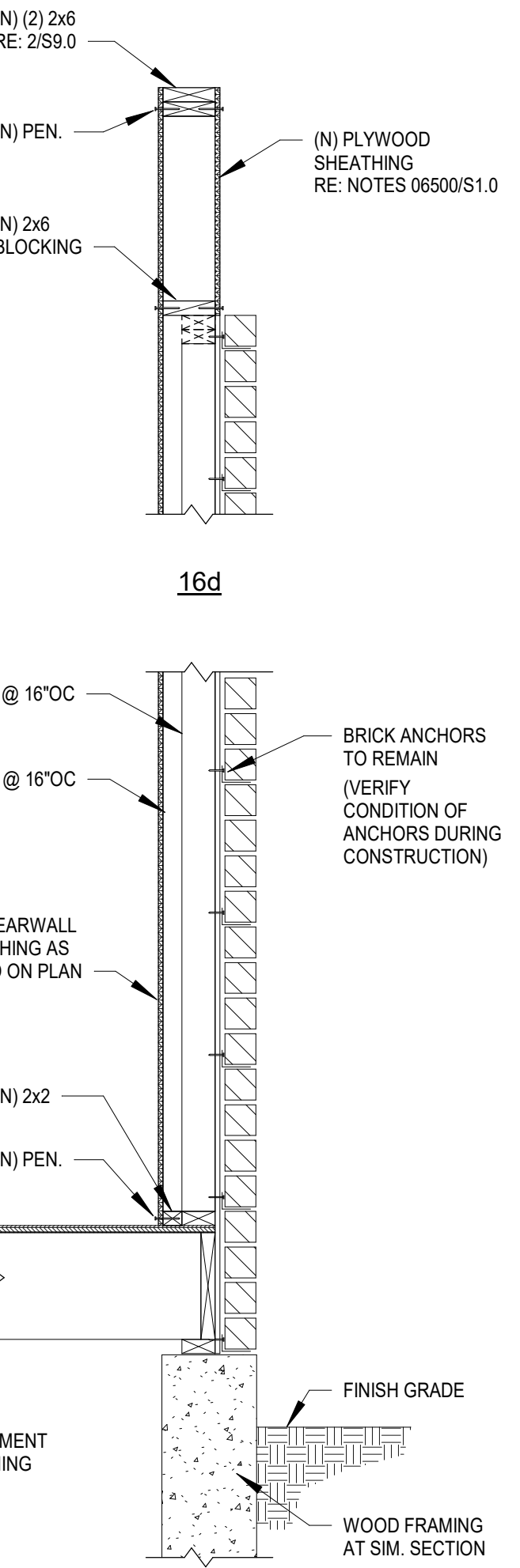
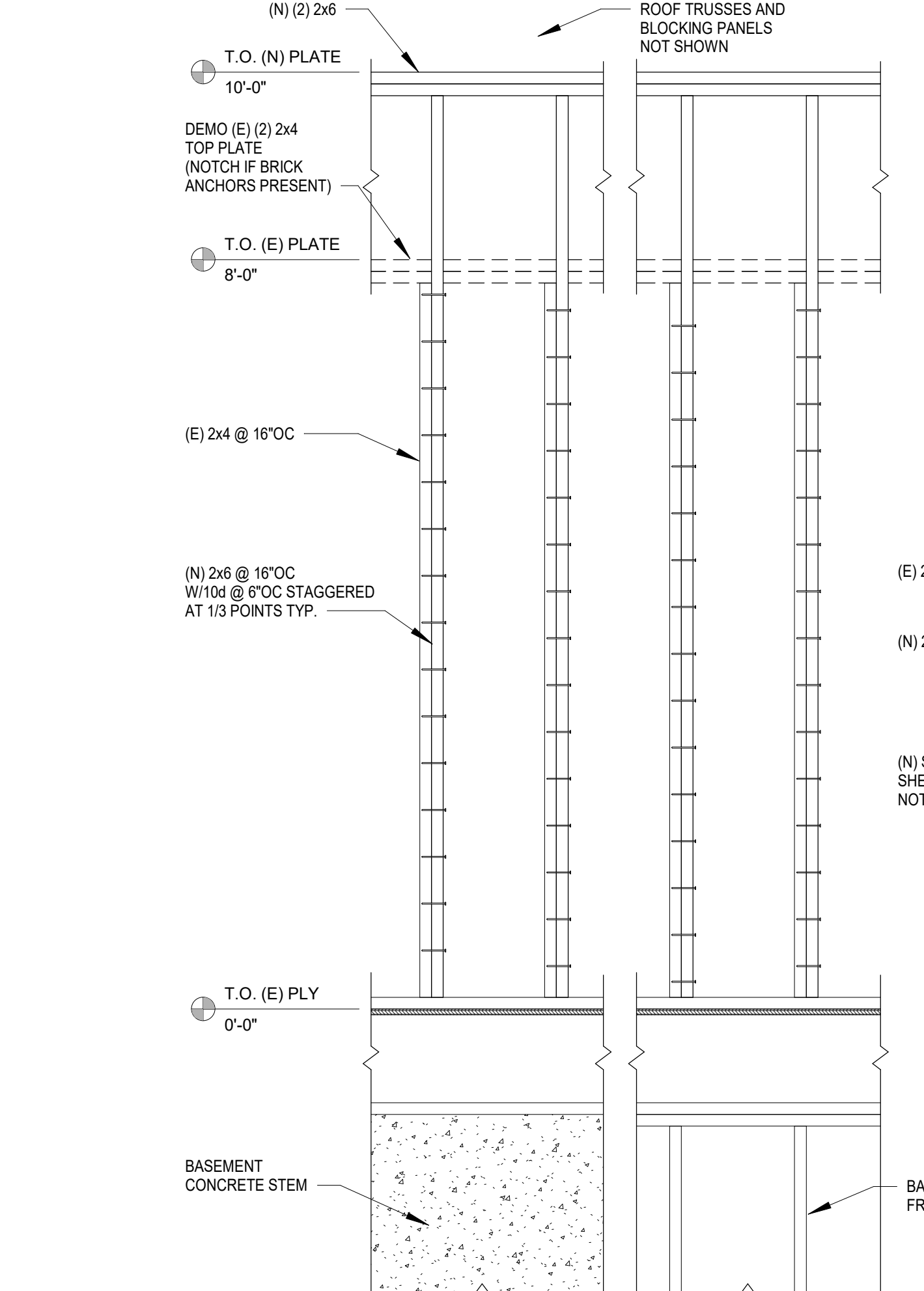

SCALE: 3/4" = 1'-0"
16 TYPICAL SISTERING OF (E) 2x4 EXTERIOR WALLS

SCALE: 3/4" = 1'-0"
16 TYPICAL SISTERING OF (E) 2x4 EXTERIOR WALLS

CT ENGINEERING INC.
 Structural Engineers
 180 Nickerson Street, Suite 302, Seattle, WA 98109
 206.285.4512 (V) 206.285.0616 (F)
 www.ctengineering.com

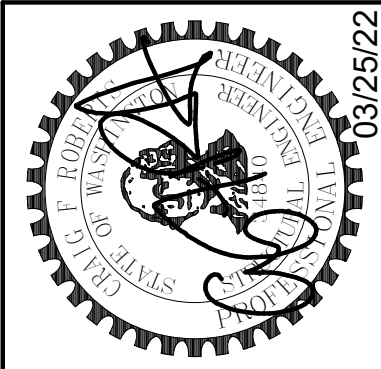

No.	REVISION	DATE

JOB #:	21162
ENG.:	Designer
CAD:	Author
SCALE:	As indicated
KEY ISSUE DATES:	
SD:	SD
BD:	BD
CD:	CD
PERMIT:	03/25/2022
OTHER:	BD

Typical Wood Framing Details
 PIPER REMODEL
 8429 SE 33RD PLACE
 MERCER ISLAND, WA 98040

S9.2

2/23/2022 4:28:09 PM
 N:\21162_Piper_Remodel\Address\STRUCT\21162_Piper_Remodel\Address\03191.dwg

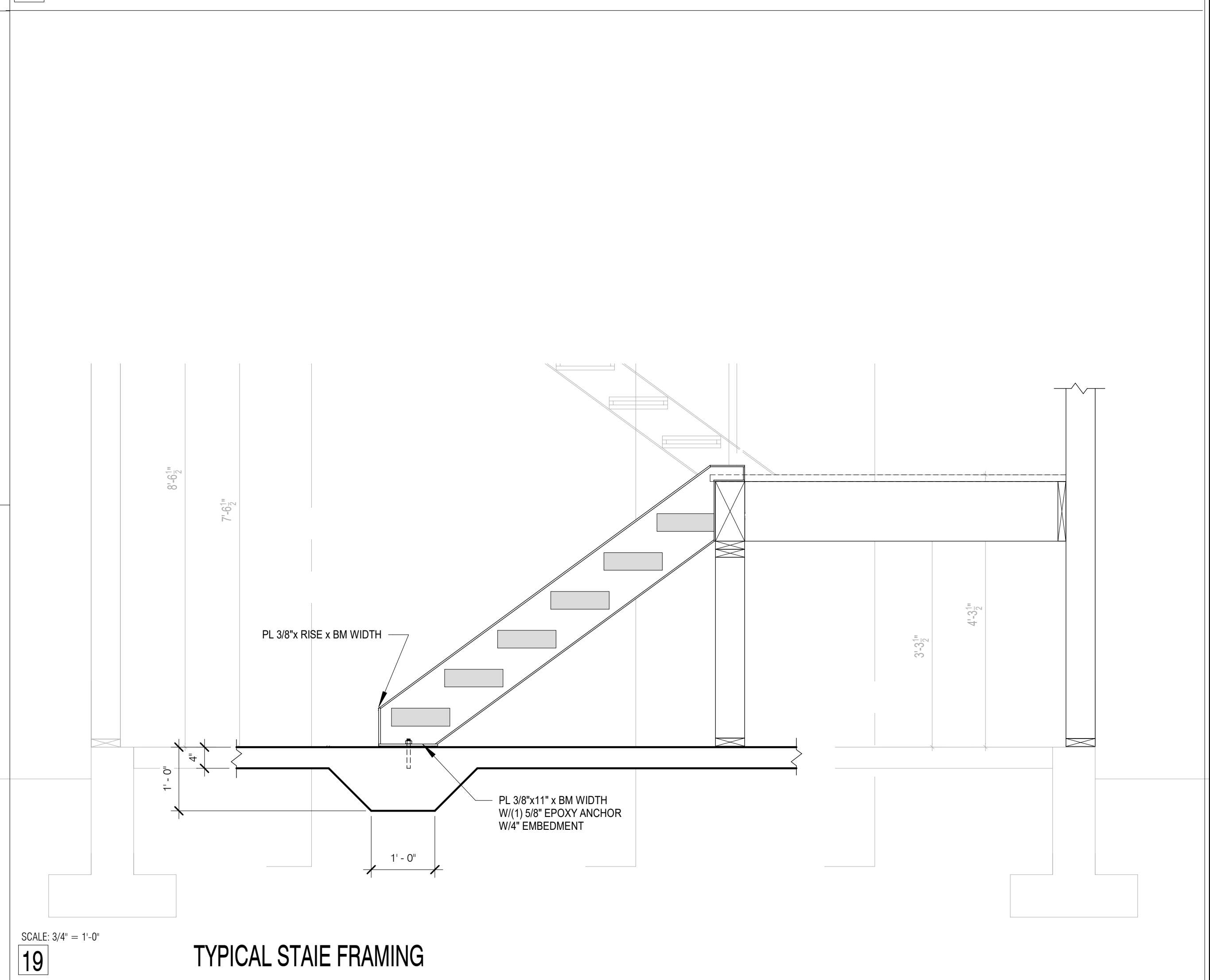
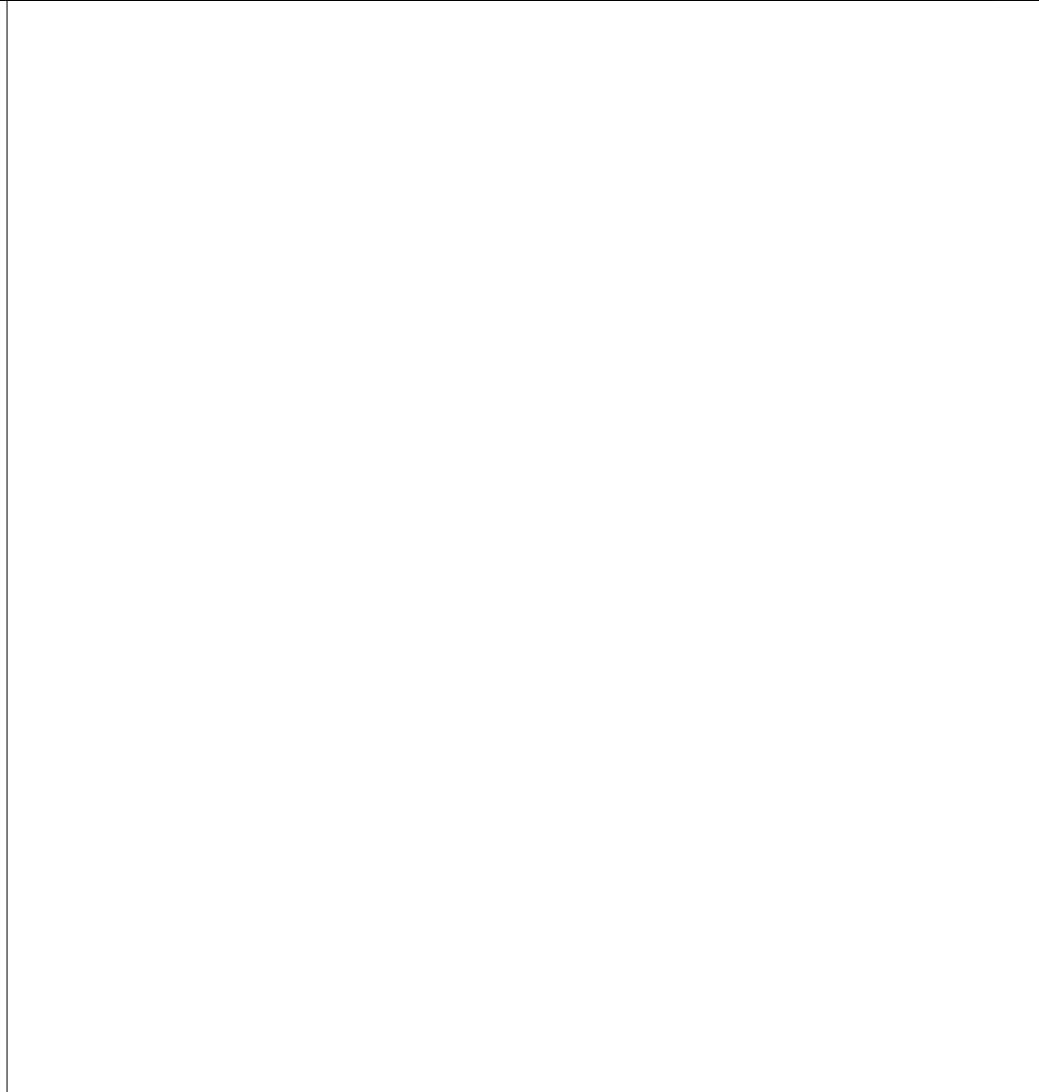
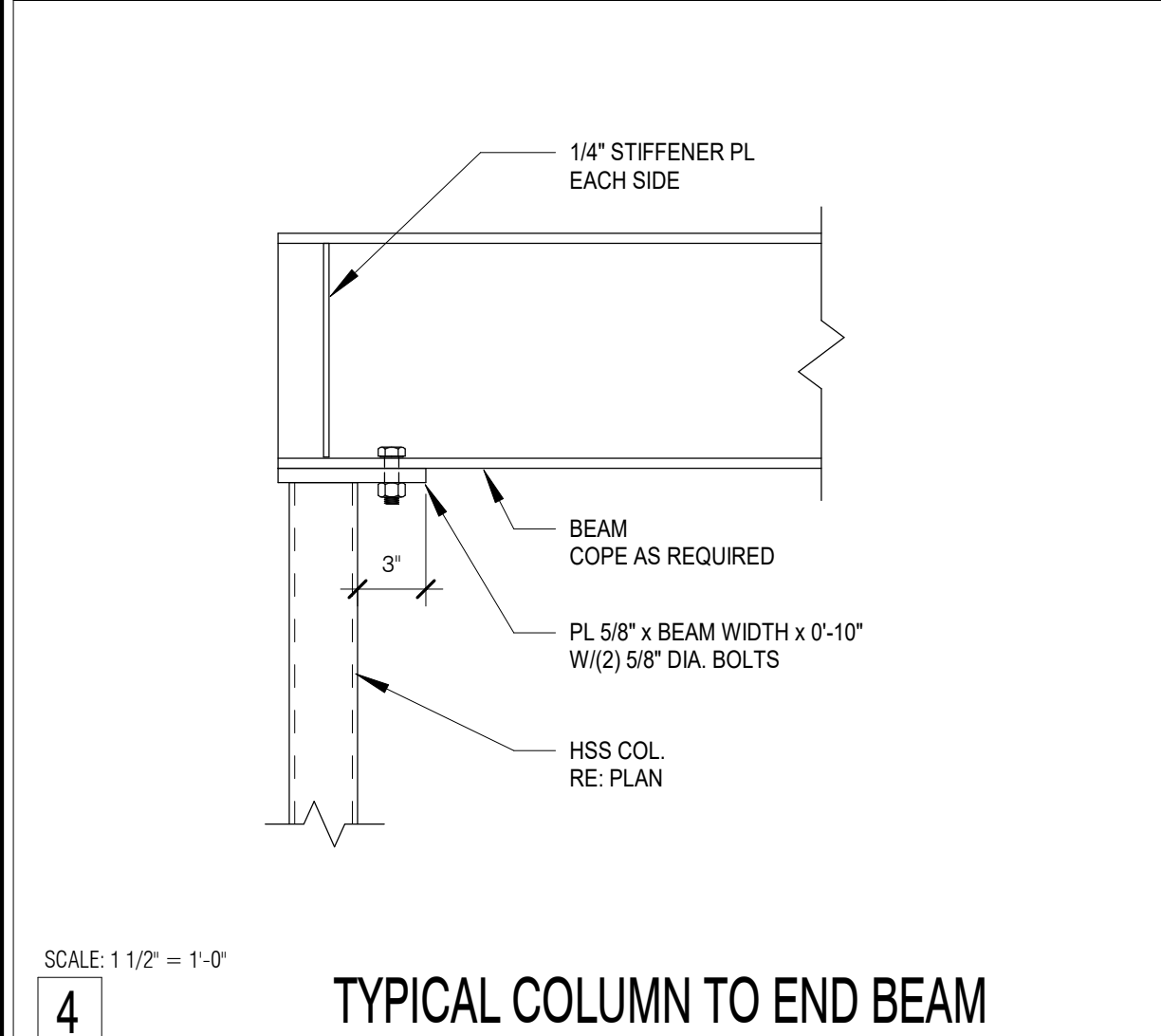
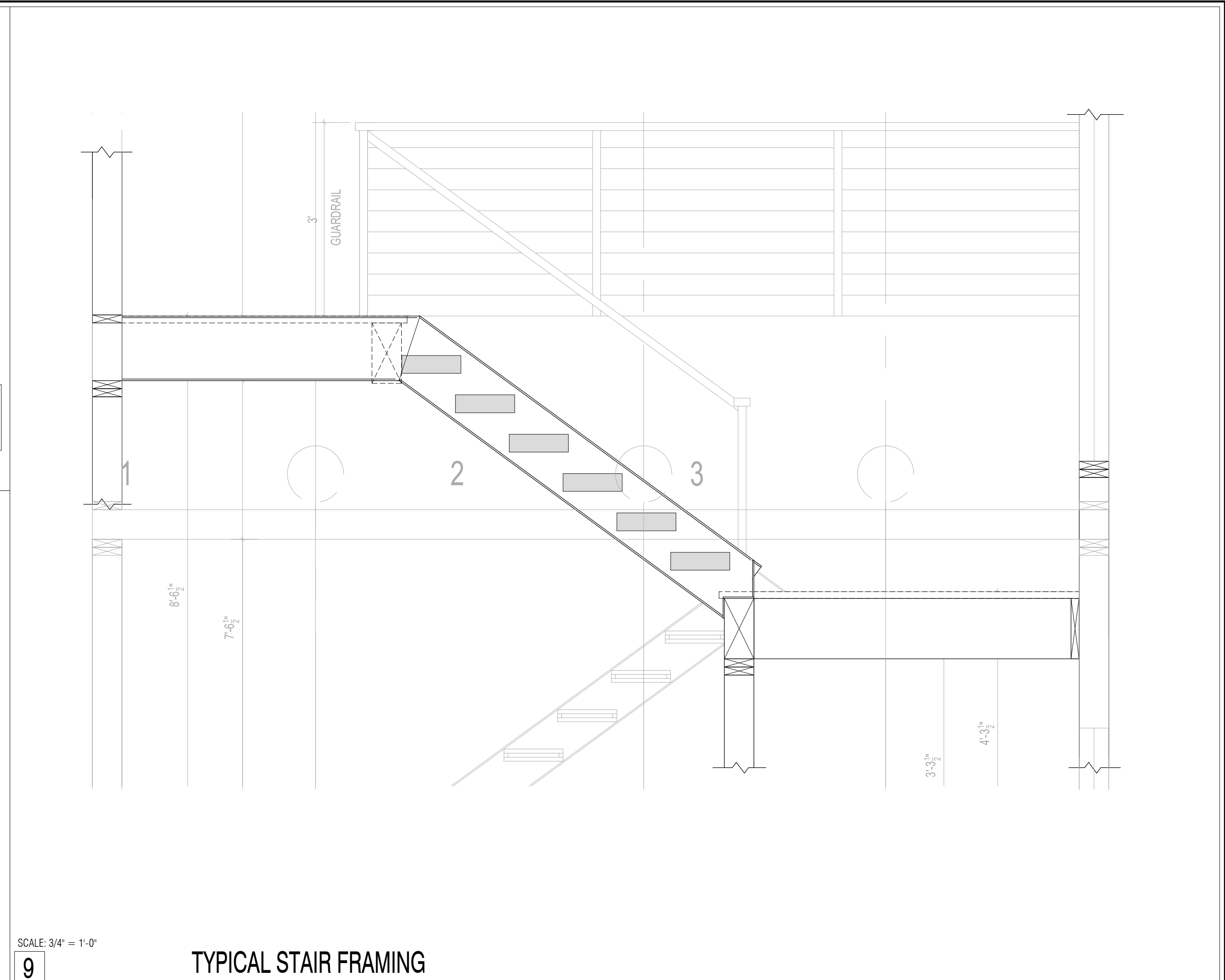
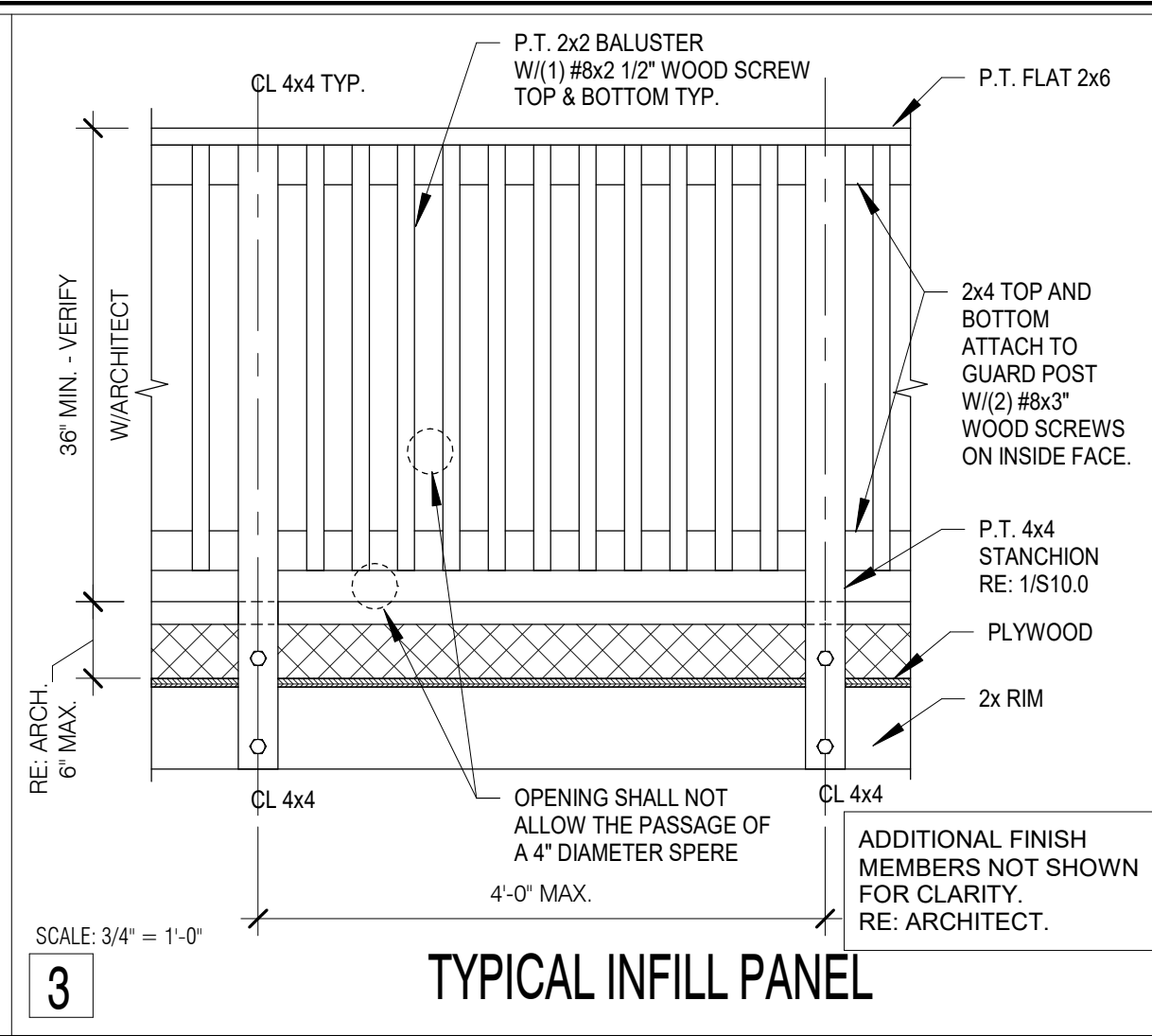
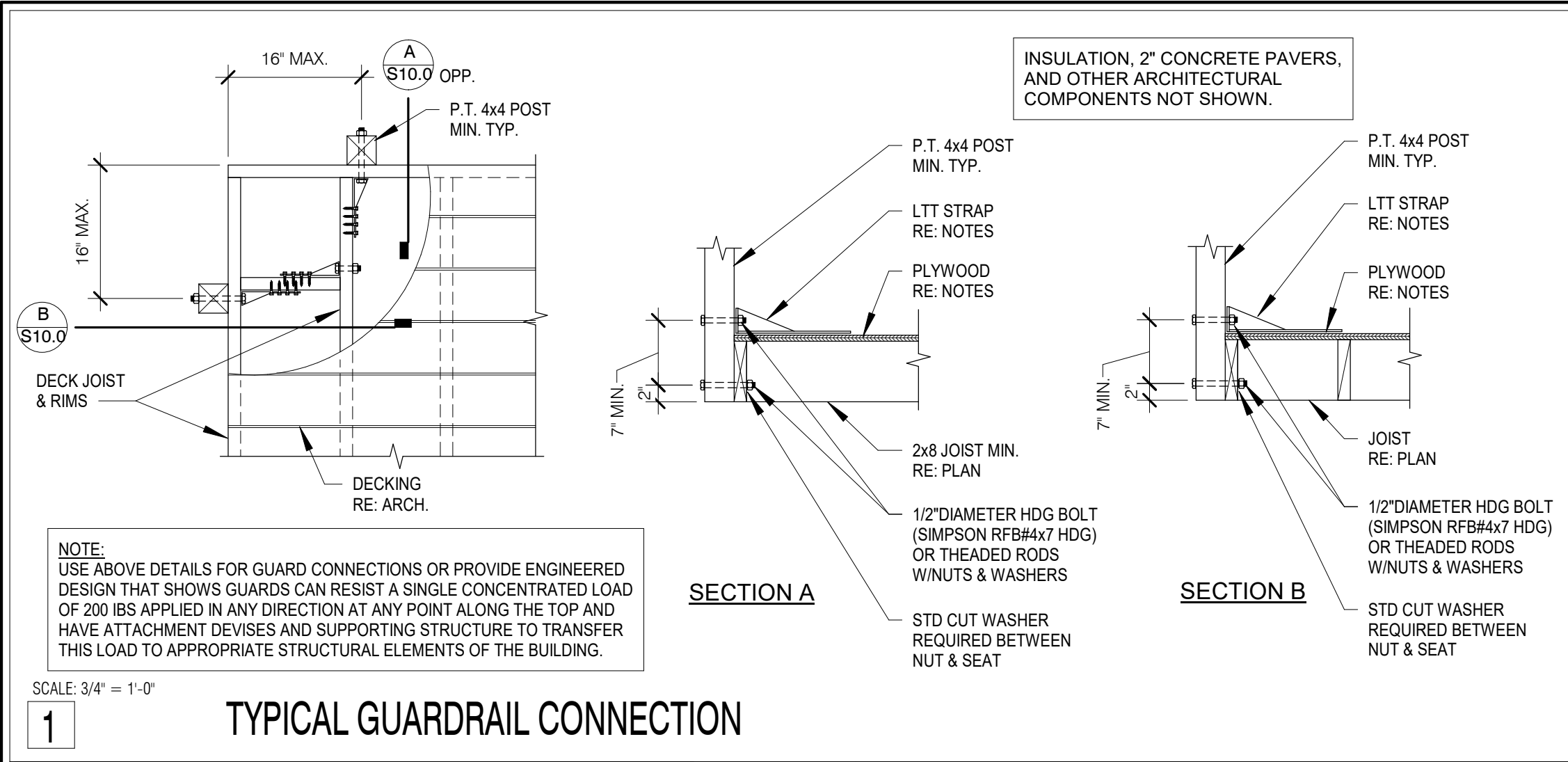

CT ENGINEERING INC.
 Structural Engineers
 180 N. Jackson Street, Suite 302, Seattle, WA 98109
 206.265.4512 (V) 206.265.0616 (F)
 www.ctengineering.com

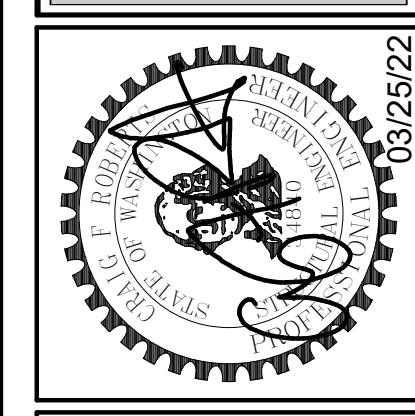

No.	REVISION	DATE

JOB #:	21162
ENG:	BJM
CAD:	JMA
SCALE:	As indicated
KEY ISSUE DATES:	
	SD
	BD
	CD
	PERMIT: 03/25/2022
	OTHER: BD

Typical Components
 PIPER REMODEL
 8429 SE 33RD PLACE
 MERCER ISLAND, WA 98040

S10.0

TOPOGRAPHIC MAP

THE NW 1/4 OF THE SW 1/4 OF SECTION 7, TOWNSHIP 24 NORTH, RANGE 5 EAST, W.M.
KING COUNTY, WASHINGTON

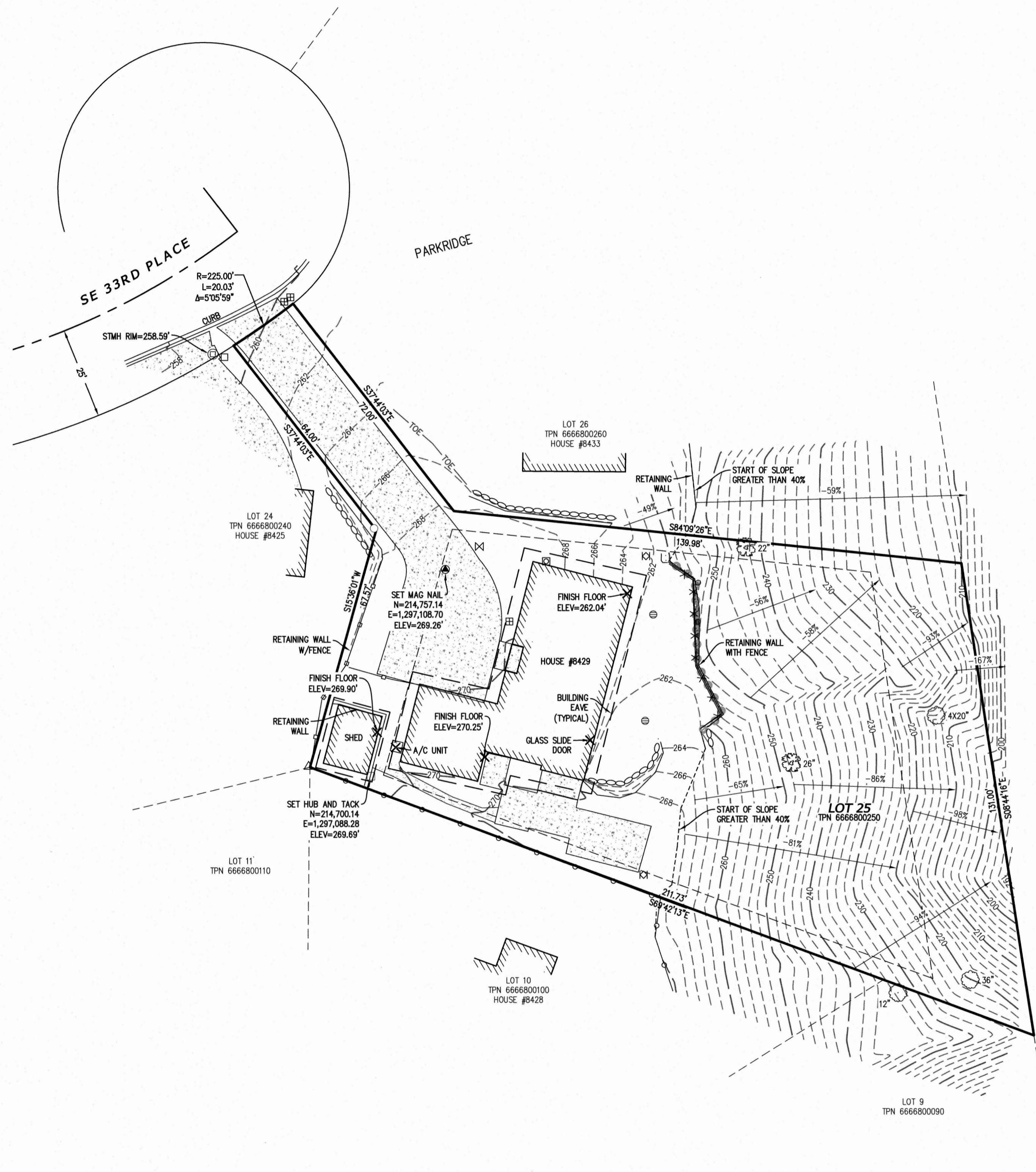

LEGAL DESCRIPTION

PER WARRANTY DEED, KING COUNTY RECORDING NO. 20200410000015
LOT 25 OF PARKRIDGE, AS PER PLAT RECORDED IN VOLUME 78 OF PLATS, PAGES 29 AND 30, RECORDS OF KING COUNTY.
SITUATE IN THE CITY OF MERCER ISLAND, COUNTY OF KING, STATE OF WASHINGTON.

HORIZONTAL DATUM

WASHINGTON STATE PLANE COORDINATE SYSTEM, NORTH ZONE (NAD 83/2011) BASED ON RTK GPS MEASUREMENTS CONSTRAINED TO THE WASHINGTON STATE REFERENCE NETWORK.

VERTICAL DATUM

NAVD 88 BASED ON RTK GPS MEASUREMENTS CONSTRAINED TO THE WASHINGTON STATE REFERENCE NETWORK.

SURVEY NOTES

- DATA FOR THIS SURVEY WAS GATHERED BY FIELD TRAVERSE UTILIZING ELECTRONIC DATA COLLECTION, AND MEETS OR EXCEEDS ACCURACY REQUIREMENTS CONTAINED IN W.A.C. 332.130.090. ALL MEASURING INSTRUMENTS EMPLOYED IN THIS SURVEY HAVE BEEN MAINTAINED IN ACCORDANCE WITH MANUFACTURER'S SPECIFICATIONS.
- THIS MAP GRAPHICALLY REPRESENTS CONDITIONS AND FEATURES EXISTING AT THE TIME OF THIS SURVEY ONLY, WHICH WAS PERFORMED DURING DECEMBER OF 2021.
- THE CERTIFICATION OF THIS SURVEY AND MAP IS EXCLUSIVE TO THE NAMED CLIENT WHO REQUESTED THIS SURVEY. IT WAS SPECIFICALLY DESIGNED TO MEET THEIR STATED NEED(S). THAT CERTIFICATION DOES NOT EXTEND TO ANY OTHER PARTIES OR FOR ANY ALTERNATIVE USE OF THIS MAP WITHOUT THE EXPRESS RECERTIFICATION BY THE SURVEYOR NAMING THOSE PARTIES.
- THE PURPOSE OF THIS SURVEY IS TO PROVIDE A TOPOGRAPHIC MAP OF THE EXISTING CONDITIONS WITHIN KING COUNTY PARCEL #666800250 FOR PLANNING, DESIGN AND CONSTRUCTION.
- UTILITIES OTHER THAN SHOWN MAY EXIST ON THE SITE. THE SURVEYOR DOES NOT WARRANT THAT THE UNDERGROUND UTILITIES SHOWN ARE IN THE EXACT LOCATION INDICATED. LACKING EXCAVATION, THE EXACT LOCATION OF UNDERGROUND FEATURES CANNOT BE ACCURATELY, COMPLETELY, AND RELIABLY DEPICTED. WHERE ADDITIONAL OR MORE DETAILED INFORMATION IS REQUIRED, THE CLIENT IS ADVISED THAT EXCAVATION MAY BE NECESSARY. THE SURVEYOR DOES CERTIFY THAT THEY ARE SHOWN AS ACCURATELY AS POSSIBLE FROM FIELD SURVEY INFORMATION.
- PARCEL AREA: 19,304 ± SQ.FT. (0.44 ACRES)
- ALL DISTANCES AND DIMENSIONS SHOWN ARE U.S. SURVEY FEET GROUND MEASUREMENTS.
- CONTOUR INTERVALS ARE 2-FOOT AND ARE COMPUTER GENERATED FROM GROUND FIELD TOPOGRAPHY GATHERED FOR THIS SURVEY UTILIZING ELECTRONIC DATA COLLECTION.
- THE PROPERTY AND RIGHT-OF-WAY LINES SHOWN HEREON ARE BASED ON FIELD TIES TO SEVERAL OF THE ORIGINAL PLAT MONUMENTS, FROM WHICH WE CONDUCTED A MATHEMATICAL CALCULATION OF THE PARCEL BASED ON THE GEOMETRY OF THE RECORDED PLAT MAP. NO PROPERTY CORNERS WERE ESTABLISHED DURING THIS SURVEY.
- WE HAVE USED GRAPHIC SYMBOLS TO REPRESENT SOME FEATURES ON THIS MAP, SUCH AS UTILITIES, TREES AND FENCES. THE DEFAULT SIZE OF THOSE SYMBOLS MAY NOT REFLECT THE TRUE SIZE OF THE FEATURE THAT WAS MAPPED.

LEGEND

- TPN TAX PARCEL NUMBER
- FOUND REBAR & CAP, LS #38992
- △ FOUND SURVEY NAIL, LS #3135
- SET MAG NAIL - AS NOTED
- SET HUB AND TACK - AS NOTED
- BOUNDARY LINE
- - - ADJONER PROPERTY BOUNDARY
- RIGHT OF WAY LINE
- ROAD CENTERLINE
- - - BUILDING SET BACK LINE
- DECIDUOUS TREE (DIAMETER AS NOTED)
- MAPLE TREE (DIAMETER AS NOTED)
- PILING
- WOOD FENCE
- CHAIN LINK FENCE
- SPLIT RAIL FENCE
- STORM MANHOLE
- STORM YARD DRAIN
- 4" PVC STORM ROOF DRAIN
- TELEPHONE RISER
- GAS METER
- WATER VALVE
- WATER METER
- IRRIGATION CONTROL VALVE
- ROCKERY
- CONCRETE SURFACE
- GRAVEL SURFACE

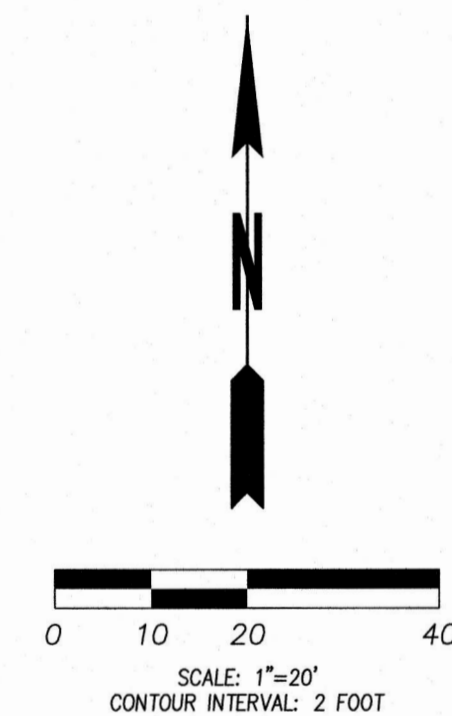

REV NO	REVISION DESCRIPTION	DATE BY
1	ADDED STEEP SLOPE INFORMATION	12/17/21 BFM



TOPOGRAPHIC SURVEY

KEVIN AND SUZETTE PIPER
8429 SE 33RD PLACE
MERCER ISLAND, WASHINGTON 98040

TITLE

CLIENT

DATE SEALED 12/20/2021



PROJECT MANAGER
KAP

DESIGN
KAP

DRAWN
BFM

CHECKED
KAP

SEC 7 T 24 N R 5 E
FILE NO 35970
DATE 12/20/2021
SCALE 1" = 20'

SHEET 1 OF 1
FILE NO 35970

SURVEYOR'S CERTIFICATE
I HEREBY CERTIFY THAT THIS MAP CORRECTLY REPRESENTS A TOPOGRAPHIC SURVEY MADE BY ME OR UNDER MY DIRECTION AND TO THE BEST OF MY KNOWLEDGE REPRESENTS THE TOPOGRAPHIC FEATURES AS THEY EXIST ON THE GROUND AS OF 12/3/2021.

KAP 12/20/2021
KURT A PARGHER P.L.S. NO. 49286 DATE